



building performance centre

42 Colinton Road
Edinburgh
EH10 5BT

T: 0131 455 5112
F: 0131 455 5121
E: bpc@napier.ac.uk
www.napier.ac.uk/bpc



**ACOUSTIC NOISE
MEASUREMENTS OF AIR
SOURCE HEAT PUMPS
(EE0214)**

September 2011



THE QUEEN'S
ANNIVERSARY PRIZES
2009



Acknowledgements

We are grateful to the Department for Energy and Climate Change for their support in sponsoring this research project. We would wish to express our thanks to Nicola Robertson, Dr Elena Prokofieva, Scott McCall, Phil Wright, Juliette Paris, Professor Sean Smith and other members of the BPC team for their assistance during the project. Thanks are also expressed to Dick Stephens at Gastec and Tony Knowles at EA Technology for assistance in the collection of electricity consumption data.

Data collection and processing:

Daniel Lurcock
B.Eng (Hons), M.I.O.A

Report preparation and analysis:

Richard Mackenzie
B.Sc., F.I.O.A, M.Inst.S.C.E

Approved by:

Professor Sean Smith
BSc (Hons), PhD, MIOA

The Building Performance Centre is based within the Institute for Sustainable Construction at Edinburgh Napier University.

Contents

1.0	Introduction	4
2.0	Background Information	7
3.0	Project Methodology	16
4.0	Overall Analysis	24
5.0	Site Analysis	32
5.1	486 Stroud	32
5.2	440 Fylde	44
5.3	418 Central Buchan	56
5.4	422 Fraserburgh (Original ASHP)	68
5.5	422 Fraserburgh, Aberdeenshire (Replacement ASHP)	81
5.6	443 Cheshire West	93
5.7	474 West Berkshire (Site 1)	104
5.8	475 West Berkshire (Site 2)	116
5.9	478 Cotswold (Courtyard)	129
5.10	478 Cotswold (Stables)	140
6.0	Suggestions and Conclusions	151
Appendix A.	Measurement Equipment	153
Appendix B.	Calibration Certificates	154
Appendix C.	Measurement Data	155

1.0 Introduction

- 1.1 The Department of Energy and Climate Change (DECC) has commissioned Edinburgh Napier University's, Building Performance Centre (BPC) to undertake a series of acoustic measurements of in-situ Air Source Heat Pumps (ASHPs).
- 1.2 Heat pumps have an important role to play in achieving Government targets on reducing CO₂ emissions.
- 1.3 Potential noise created by these systems has often been highlighted as a restricting factor at planning stages and often required expensive acoustic assessments.
- 1.4 There is little data available on the actual noise level of ASHP units when installed on real sites. Instead, designers, planners and customers have had to rely on manufacturers' performance claims, which are typically based on lab testing in ideal conditions.
- 1.5 The aim of Contract EE0214 was set out in the 'Invitation To Tender' and is reproduced below:
- 1.6 *The aim of these acoustic studies is not to establish the noise levels at the nearest neighbour, but rather, to measure the sound pressure level at 1m from the heat pump, and to undertake a tonal noise analysis. If tonal noise is found to be present, this information will be fed back to manufacturers, together with information on the heat output and electrical demand. This should enable manufacturers to pinpoint the source of the tone(s) and perhaps enable mitigation.*

- 1.7 The study involved measurements at 9 sites across the UK between February and March 2011. The sites are all participating in the ongoing energy performance trials being undertaken by the Energy Saving Trust (EST). The sites were selected by DECC in conjunction with BPC and the EST contractors to represent a range of typical ASHP available on the market.
- 1.8 Table 1-1 presents the sites selected for the acoustic assessment, along with the measurement dates, the ASHP manufacturer and power output rating. Locations are given with respect to their Local Authority designated district.

Table 1-1: Site Assessment Details			
Site Code	Measurement Dates	Site Location	ASHP Description
478	31 st Jan – 7 th Feb	Cotswold (courtyard)	8.5 kW Manufacturer A
479	31 st Jan – 7 th Feb	Cotswold (stables)	8.5 kW Manufacturer A
422	8 th Feb – 15 th Feb	Fraserburgh	8.0 kW Manufacturer B
422	2 nd Mar – 9 th Mar	Fraserburgh	6.0 kW Manufacturer B
418	9 th Feb – 15 th Feb	Central Buchan	8.0 kW Manufacturer B
443	16 th Feb – 22 nd Feb	Cheshire West	8.2 kW Manufacturer C
440	16 th Feb – 22 nd Feb	Fylde	9.0 kW Manufacturer D
474	23 rd Feb – 1 st Mar	West Berkshire (Site 1)	9.1 kW Manufacturer E
475	23 rd Feb – 1 st Mar	West Berkshire (Site 2)	5.5 kW Manufacturer E
486	8 th Mar - 15 th Mar	Stroud	8.0 kW Manufacturer F

- 1.9 Site 422 was assessed twice as the ASHP was changed for a new unit between the measurement periods.
- 1.10 The acoustic measurements were made in coordination with the EST trial contractors, who made simultaneous measurements of the ASHP energy use to enable an analysis against the acoustic data.

1.11 The detailed requirements of the project are outlined below:

- Undertake acoustic measurements of the noise emissions from 10 air source heat pumps installed at residential sites throughout the UK.
- Undertake measurements of the background noise during periods when the air source heat pumps are not operating.
- Conduct equivalent continuous sound pressure level L_{eq} measurements of air source heat pumps over 1 minute periods for one week at each site.
- The measurements to be made in accordance with BS EN ISO 3746:2010 to allow the sound power level of each unit to be determined.
- Ensure that the equipment is synchronised to record with the data loggers used for monitoring heat and electricity.
- Undertake FFT spectral analysis to allow an assessment of tones using the Joint Nordic Method.
- Produce a report outlining the measurements made including site photographs, equipment set up, weather conditions etc.
- Include spectral charts of the noise, showing tones, if found, and classify tones according to the Joint Nordic Method.
- Include recommendations for improving the acoustic performance of air source heat pumps, if appropriate.

2.0 Background Information

What is an Air Source Heat Pump?

- 2.1 An ASHP takes latent heat from outside air and concentrates it to a higher temperature, high enough to provide heating to, for example, a domestic central heating system.
- 2.2 ASHPs work very much like a domestic refrigerator whereby heat energy is transferred from one place to another using heat exchangers and a refrigerant fluid going through a process of compression and expansion. A diagram of the main components of the refrigeration cycle is shown in Picture 2-1, in which **1** represents the heat exchanger where the high temperature refrigerant transfers heat to the heating system; **2** represents the expansion of the refrigerant at the expansion valve, where the refrigerant cools down; **3** represents the heat exchanger where outside air transfers heat to the refrigerant; and **4** represents the electrically powered compressor, which compresses the refrigerant, causing it to increase in temperature.

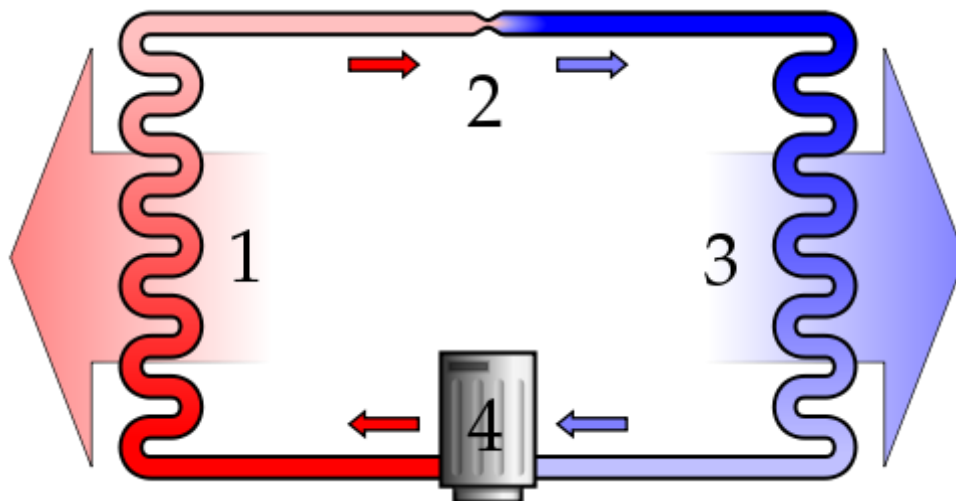

Picture 2-1: Diagram of ASHP Refrigeration Cycle

- 2.3 In addition to the main refrigeration components shown above, ASHPs also include a fan, to push a greater amount of air through the external heat exchanger, in order to accelerate the heat transfer process.

How do air source heat pumps generate noise?

- 2.4 The main components of the ASHP in terms of noise generation are the compressor and the fan, with slight noise also provided by the expansion valve and any electrical transformers associated with the system.
- 2.5 A variety of compressor types could be used within an ASHP system such as reciprocating, scroll or screw types. However, the scroll type is generally favoured by ASHP manufacturers on account of its higher efficiency, lower maintenance and lower noise level.
- 2.6 Fans used in ASHPs are typically of the axial type, with four blades, although centrifugal fans are sometimes used.
- 2.7 As part of background work for the project, a microphone array system was hired for the purpose of investigating an ASHP. The 'Acoustic Camera' array system consists of 225 individual microphones, the signals from which are processed through beam-forming software. The software then gives an indication of the areas that sound is coming from, dependent on the acoustic frequency. Images indicating the noise output from a typical ASHP are given in Picture 2-2 and Picture 2-3 for the ASHP casing on and off respectively.

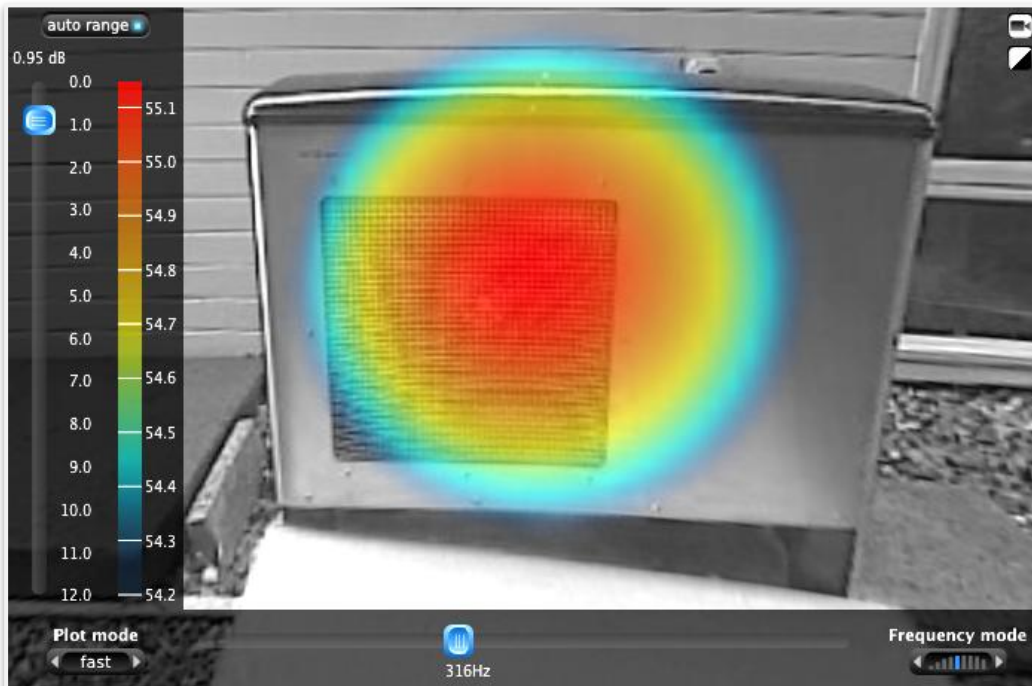

Picture 2-2. Noise output from typical ASHP, casing on

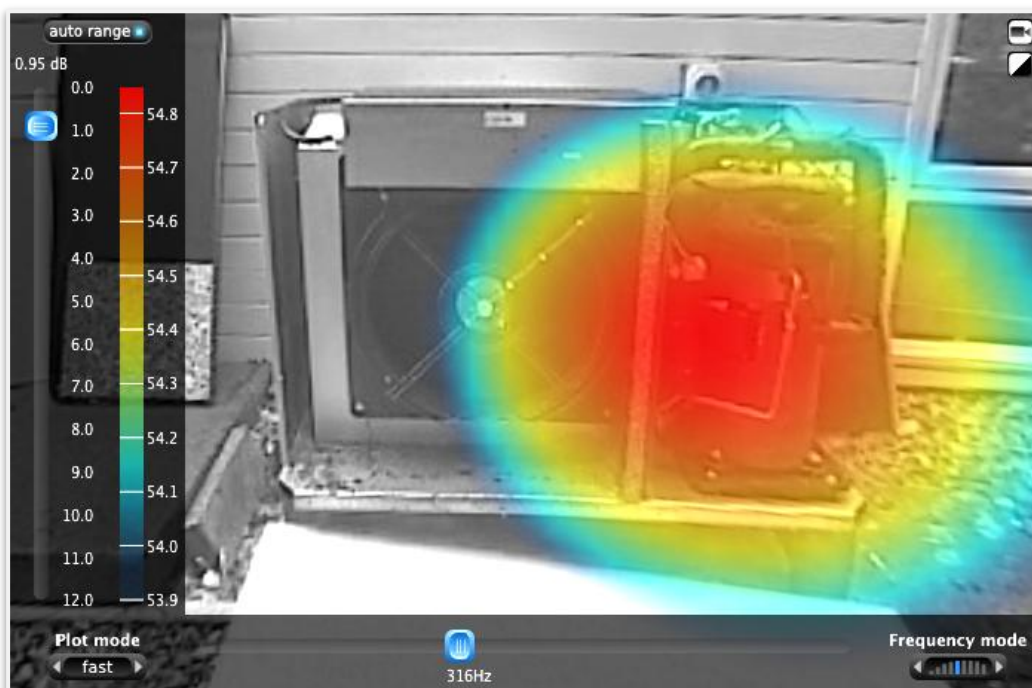

Picture 2-3. Noise output from typical ASHP, casing off

2.8 Table 2-1 presents typical noise levels for a variety of domestic appliances and items.

Table 2-1: Example Approximate Sound Pressure Levels dBA (dB re 2 x 10⁻⁵ Pa)	
Noise source	Sound Pressure Level
Chainsaw @ 1m	110
Food blender @ 1m	90
Hairdryer @ 1m	80
Vacuum cleaner in typical domestic room	70
ASHP @ 1m	60
Refrigerator @ 1m	40

Defrost cycle

- 2.9 As the refrigerant expands and cools during the refrigeration cycle, it is inherently at a lower temperature than the ambient air. This can cause water in the air to condense and freeze on the heat exchanger. The frozen water reduces the efficiency of the heat exchange process and therefore ASHPs must be equipped with a defrost cycle. During this cycle, it is normal to run the compressor in reverse for a short time at its maximum power. This increases the temperature at the outside heat exchanger and melts any ice which has collected. However, the process can produce a different noise signature, and with the absence of any masking noise provided by the fan, any tones can be more prominent than during normal operation.

Manufacturer noise data

- 2.10 In product literature and specifications, manufacturers present the A-weighted sound power level as required by the Microgeneration Certification Scheme (MCS). Some manufacturers additionally provide sound pressure level data at defined distances, although it is not usually stated under which conditions such sound pressure levels would be valid.

- 2.11 It is not common for manufacturers to provide frequency information on their ASHPs. Whilst some manufacturers are known to provide basic octave band levels, no manufacturers are known to provide information on any kind of tonal adjustment that may be appropriate.

Ground Source Heat Pumps

- 2.12 Another popular type of heat pump technology is the Ground Source Heat Pump (GSHP). This works in a similar fashion to the ASHP, but instead of using latent heat from the surrounding air, pipes pass the refrigerant down bore holes, where heat is transferred from the latent ground temperature. Since GSHPs do not need access to an external air supply, they do not require a fan and are usually located indoors. As such they tend to be designed to achieve lower noise levels than ASHPs. The compressor demand for GSHPs is also not as high as required for ASHPs due to the fact that ASHPs must be designed to operate with a lower source temperature (i.e. during winter, air temperatures can be significantly lower than ground temperatures). The absence of a fan and reduced compressor power capacity requirement allows lower noise levels to be achieved with GSHPs.

Planning and Noise

- 2.13 To protect the amenity of neighbouring residential properties, it is important for the planning system to control the noise emitted from any domestic mechanical plant including ASHPs.
- 2.14 In order to encourage the uptake of domestic micro generation and energy efficient devices such as ASHPs, the English planning system has been under review to establish a streamlined system of Permitted Development Rights that remove the need for a planning application and associated noise impact assessments. Permitted Development Rights are granted subject to limitations and conditions that are designed to limit impacts on neighbouring properties.

- 2.15 In Scotland, Ministers are committed to promoting a greater uptake of microgeneration technology. Part of that approach has been the introduction of permitted development rights for microgeneration technology for domestic and non-domestic property. Legislation was introduced in 2009 for domestic properties and the Climate Change (Scotland) Act 2009 supported further permitted development rights for microgeneration equipment. Further Permitted development rights were introduced for domestic properties in 2010 and for non-domestic properties in 2011.
- 2.16 Scottish Planning Series: Planning Circular 2 2010: The Town and Country Planning (General Permitted Development) (Domestic Microgeneration) (Scotland) Amendment Order 2010 permits Class 6H: Air Source Heat Pumps to be installed within the curtilage of a dwelling provided that the installation is not less than 100 metres from the curtilage of a neighbouring dwelling.
- 2.17 The Scottish Government have more recently consulted on “Extending Permitted Development Rights for domestic micro-wind turbines and air-source heat pumps”.
- 2.18 This consultation proposed a noise based limit of 45 dBA at the nearest neighbour’s curtilage, or 30 dBA within any neighbour’s room. These criteria would replace the 100m distance on which was previously consulted and applied in the 2010 Order and have the effect of granting Permitted Development Rights for flats where acceptable noise limits can be achieved.
- 2.19 The choice of 45 dBA outside a property and 30 dBA within rooms is in line with the RMP Acoustics report commissioned by the Scottish Government “Services noise affecting dwellings”, December 2007:
<http://www.scotland.gov.uk/Resource/Doc/217736/0090922.pdf>
(Internet link accessible as of September 2011.)

- 2.20 However in November 2010, the Minister for Transport, Infrastructure and Climate Change wrote to the Convener of the Local Government and communities committee, stating 'Micro wind turbines generate noise and have the potential to cause an impact on aviation operations, particularly for communications, navigation and surveillance equipment. Air source heat pumps also generate noise. We have investigated potential 'thresholds' for PDR. It has not been possible to identify a threshold (taking account of variations in background noise) allied to a consistent measurement technique that would provide adequate safeguards. The planning permission process allows the individual site and product circumstances to be assessed case by case, providing appropriate safeguards for neighbours and providing owners with certainty that their consent may include conditions that will need to be met.'
- 2.21 In 2009, the UK government issued a consultation for planning in England and Wales "Permitted Development Rights for small scale renewable and low carbon energy technologies, and electric vehicle charging infrastructure: Consultation"
- 2.22 This consultation proposed a noise-based limit with the effect that:
- "The noise level from the installation must not exceed 45dB $L_{Aeq(5min)}$ at 1 metre from the window of a habitable room in the facade of any neighbouring residential property (but ignoring the effect of that facade)."*
- 2.23 The facade level selected is in line with World Health Organization (WHO) guidance on noise levels above which sleep disturbance may occur. However, the instruction to ignore the facade effect may be inconsistent with the WHO guidance as this effectively raises the limit by 3 dBA to 48 dBA.
- 2.24 In September 2011 The Town And Country Planning (General Permitted Development) (Amendment) (England) Order 2011 was issued which from 1 December 2011 permits the installation of an ASHP provided the noise level

does not exceed 42dB $L_{Aeq(5min)}$ at 1 metre from the window of a habitable room in the facade of any neighbouring residential property. The limit will be reviewed one year after the new rights come into force, to consider whether or not the initial experience justifies a change to the noise limit.

Microgeneration Certification Scheme (MCS)

2.25 The MCS scheme provides a method for establishing certification of noise levels for small scale power generating and energy efficient systems. Micro wind turbine certification is the most developed part of the scheme. Most new micro wind turbine are submitted to an approved certification body for acoustic testing.

2.26 The testing establishes the sound power of the turbine, whether it is tonal and the predicted noise level at a given distance from the turbine for a given wind speed. The traffic light warning system indicates distances in red where levels above 45 dBA may occur. An example of a British Wind Energy Association (BWEA) MCS Noise Label is shown below in Picture 2-4.

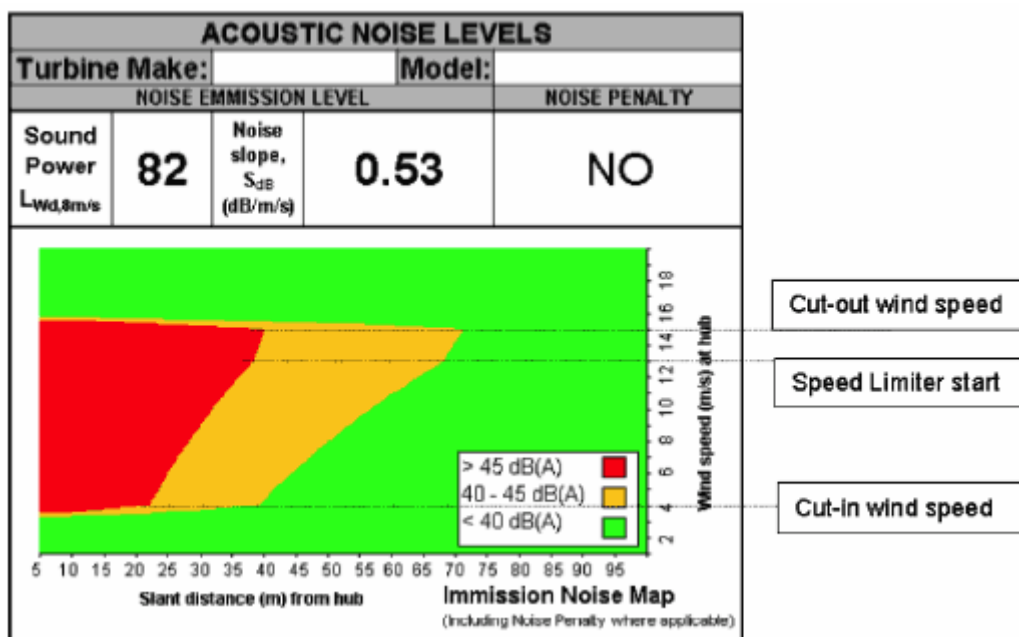

Picture 2-4: Example BWEA MCS Noise Label

- 2.27 The scheme for ASHP (MCS 007) currently requires that ASHP sound characteristics should be measured under laboratory conditions in accordance with BS EN 12102 – 2008 “Air conditioners, liquid chilling packages, heat pumps and dehumidifiers with electrically driven compressors for space heating and cooling – Measurement of airborne noise – Determination of the sound power level”
- 2.28 The Microgeneration Installer Standard for ASHPs is MIS 3005 and sets out the following requirements for noise:
- The location of external fans, for example in air-source heat pumps, should be chosen to avoid nuisance to neighbours.
 - Internal fans and ducts should be fitted with sound attenuation devices.
- 2.29 However, there is currently no requirement to produce a MCS noise label defining an ASHP’s noise level at extended distances from the unit, in a similar method to that for micro wind turbines.
- 2.30 There are no MCS standards for the provision of vibration mitigation. However, the general requirements state that the heat pump must meet the relevant test standards and the vibration characteristic should be monitored in accordance with BS EN 1736:2000 – ‘Refrigerating systems and heat pumps. Flexible pipe elements, vibration isolators and expansion joints. Requirements, design and installation’.
- 2.31 MIS 3005 sets out the following requirements for vibration:
- Heat pumps should not be located adjacent to sleeping areas or on floors that can transmit vibration
 - Anti-vibration pads/mats/mounts and flexible hose connections should be used to reduce the effects of vibration on the building structure.

3.0 Project Methodology

Measurement methodology

- 3.1 The acoustic measurements were made in accordance with BS EN ISO 3746:2010 Acoustics – “Determination of sound power levels and sound energy levels of noise sources using sound pressure – Survey method using an enveloping measurement surface over a reflecting plane.”
- 3.2 The measurement positions were selected to be in accordance with Annex C – “Microphone arrays on a parallelepiped measurement surface”.
- 3.3 With the exception of site 486 Stroud, the air source heat pumps were all mounted on the ground adjacent to 2 or 3 reflecting planes, therefore the methodology in Sections C2 of the standard applied.
- 3.4 At site 486 Stroud the ASHP was wall mounted at first floor level, which would normally only have one reflecting plane. However, due to the presence of a brick outhouse approximately 1m from the rear wall of the house it was felt that the site situation was characteristic of 2 reflecting planes.
- 3.5 Section C2 requires that three or four microphones, depending on whether there are 2 or 3 reflecting planes, be set-up in an array around the air source heat pumps as indicated in Figures C.7 and C.8, which are reproduced overleaf.
- 3.6 Each microphone was positioned 1 m (d , as shown in C.7 and C.8) from the ASHP on its respective plane. The height of the microphones and distance from the house wall varied on each site depending on the size of the ASHP casing.
- 3.7 Deviations from the recommended set up due to individual site requirements are discussed further in Section 5.

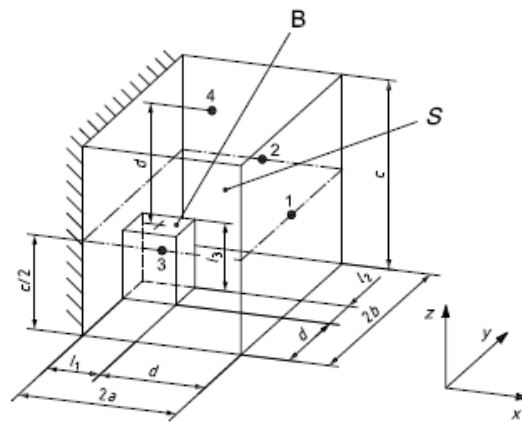

- Key**
- microphone positions (1, 2, 3, 4)
 - B reference box
 - $2a$ measurement surface length
 - $2b$ measurement surface width
 - c measurement surface height
 - d measurement distance
 - l_1 reference box length
 - l_2 reference box width
 - l_3 reference box height
 - S measurement surface
- $$S = 2(2ab + bc + 2ca)$$

Figure C.7 — Parallelepiped measurement surface with four microphone positions for floor-standing noise sources adjacent to two reflecting planes

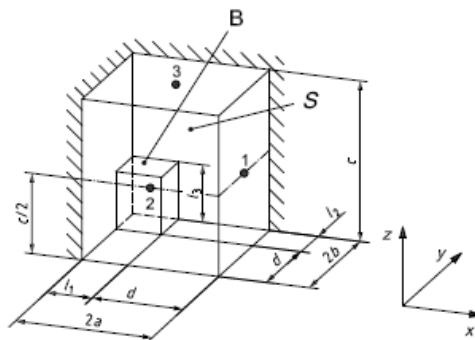

- Key**
- microphone positions (1, 2, 3)
 - B reference box
 - $2a$ measurement surface length
 - $2b$ measurement surface width
 - c measurement surface height
 - d measurement distance
 - l_1 reference box length
 - l_2 reference box width
 - l_3 reference box height
 - S measurement surface
- $$S = 2(2ab + bc + ca)$$

Figure C.8 — Parallelepiped measurement surface with three microphone positions for floor-standing noise sources adjacent to three reflecting planes

- 3.8 The measurements were made at each site using Brüel & Kjær PULSE multichannel data acquisition and analysis systems. Two PULSE systems were used: 9 channel and 5 channel systems.
- 3.9 Brüel & Kjær Type 4186 microphones were used and fitted with Brüel & Kjær UA1404 outdoor weather protection microphone kits.
- 3.10 All the equipment used meets the requirements of IEC 61672:2002, Class 1 as recommended in BS EN ISO 3746:2010.
- 3.11 At the start and end of the weeks' measurements the systems were calibrated using a Brüel & Kjær Type 4231 acoustic calibrator conforming to IEC 60942.
- 3.12 Full details of the equipment used are presented in Appendix A.
- 3.13 The equipment was submitted for external third party calibration within the last year in accordance with manufacturers' recommendations. Copies of the calibration certificates are included in Appendix B.
- 3.14 The advantage of using the PULSE system is that it allowed full resolution audio signals to be recorded for all microphone positions simultaneously for the full week, therefore allowing re-analysis of the audio signal to derive any acoustic parameter required over any time period required. The main drawback is the amount of data that is collected, over 750GB per site.
- 3.15 At each site the microphones were mounted on tripods or supported from a metal framework, depending on site requirements.
- 3.16 To ensure that the acoustic measurements could be synchronised with the electricity data loggers, the internal time clocks of both sets of equipment were compared.

- 3.17 A weather station was set up at each site to record temperature, rainfall, wind strength and direction over the week. Full details of the meteorological equipment used are presented in Appendix A.
- 3.18 Photographic records of the test arrangements were recorded at all sites.

Additional vibration measurements

- 3.19 Simultaneous measurements of the vibration levels transferred into the building structure and/or ground slab, depending on where the unit was mounted, were also made. This was used to analyse the background and source vibration levels entering the building.
- 3.20 Where the 9 channel system was being used, an additional accelerometer was mounted on the ASHP casing. This allows determination of the performance of different mounting arrangements by calculating the mounting transfer functions.
- 3.21 Brüel & Kjær Type 4508 accelerometers were bonded to the structure and casings using cyanacrylate cement.
- 3.22 At the start and end of the measurement periods the systems were calibrated using a Brüel & Kjær Type 4294 vibration calibrator.
- 3.23 Full details of the equipment used are presented in Appendix A. Copies of the calibration certificates for the vibration calibrators are included in Appendix B.

Analysis methodology

- 3.24 It was agreed at the initial project meeting with DECC that the analysis would be carried out in one minute periods.
- 3.25 The audio recordings have been analysed to determine the average noise level $L_{Aeq(1min)}$. The 'A' in the parameter indicates that the noise signal has had a filter applied to the signal to represent the hearing characteristics of the human ear, normally termed an 'A' weighting.

- 3.26 The 1 minute assessment periods result in over 10,000 readings for each parameter, for each microphone position, at each site.
- 3.27 With this amount of data it is necessary to consider how best to analyse the data in order to draw clear and appropriate conclusions.
- 3.28 For each site a chart has been produced initially presenting the $L_{Aeq(1min)}$ measured noise levels at the microphone 1m in front of the unit set against time, along with the ASHP energy use.
- 3.29 The 10,000 data points, when assessed against the energy data, can be divided into three categories:
- Background noise when the ASHP was off
 - Ambient noise when the ASHP was on (including defrost cycles)
 - Periods when the ASHP was shutting down or starting up which contain both background noise and ASHP noise.
- 3.30 The first step in analysing the data is to discount as many periods as possible that contain start up and/or shut downs, as these periods are not representative of either of the states required for the analysis.
- 3.31 The ambient measurements containing the ASHP noise were then corrected for the influence of the background noise as appropriate in accordance with the recommendation in BS EN ISO 3746:2010.
- 3.32 For the next stage of analysis a scatter diagram plotting the noise levels against the energy use was produced in order to assess any trends in how the energy consumption affects the noise levels.
- 3.33 A statistical analysis plot of the percentage of time that a specific noise level would be recorded has been produced for both the specific noise. From this confidence intervals can be presented for the typical noise levels for periods of operation.

- 3.34 As each ASHP is operated for different lengths of time over a week, the total noise dose from each ASHP over the week has been calculated.
- 3.35 Once the ASHP noise level has been established for each microphone the directivity in noise emissions from the unit can be assessed by comparing the noise levels at the different microphones, for a representative period.
- 3.36 Following establishment of the typical range of noise levels for the ASHP operating under what is considered to be normal operations, further analysis of the measurements was made to determine if there are periods when the ASHP produces higher or lower noise, such as during start up, shut down or during the defrost cycle.
- 3.37 This process is undertaken manually by listening to the audio from the relevant periods to determine the source of the noise and the corresponding noise level. For this exercise, the analysis periods were required to be flexible (i.e. more or less than 1 minute) in order to properly assess the noise event under consideration.

Sound Power Level calculations

- 3.38 Calculations of the ASHP sound power levels have been undertaken in accordance with BS EN ISO 3746:2010 Acoustics – “Determination of sound power levels and sound energy levels of noise sources using sound pressure – Survey method using an enveloping measurement surface over a reflecting plane.”
- 3.39 The calculation procedure uses the sound pressure level recorded at all microphone positions.
- 3.40 A statistical analysis plot of the percentage of time that a specific sound power level would be recorded has been produced. From this confidence intervals can be presented for the typical sound power levels.

- 3.41 From the sound power level, the estimated sound pressure level at any distance from the ASHP may be calculated from

$$L_{pA} = L_{wA} - 20 \log r - 5 \quad \text{Equation 1}$$

Where L_{pA} is the A-weighted sound pressure level (dB re 2×10^{-5} Pa);
 L_{wA} is the A-weighted sound power level (dB re 10^{-12} W),
and r is the separation distance (m).

Note: the above formula assumes the common mounting scenario that the ASHP is located against a wall at ground-floor level, and over hard ground.

Tonal assessment

- 3.42 The tonal assessment has been undertaken in two stages due to the amount of data collected. A full Fast Fourier Transform (FFT) analysis of the weeks' one minute periods would yield 68 million noise levels.
- 3.43 Therefore a 1/12 octave band analysis of the weeks' measurements has been carried out initially. The spectra have been analysed with a custom computer code (Microsoft Excel VBA procedure) identifying any peaks which may indicate audible tones.
- 3.44 Representative periods which are identified as potentially tonal were then further assessed by producing a FFT spectrum processed (through a Microsoft Excel VBA procedure) to the requirements of the Joint Nordic Method – Version 2 1999 (JNM2).

- 3.45 The FFT spectrum was analysed using the following setup:
- A-weighting. The A-weighting improves the tone assessment in the low-frequency range.
 - Linear time averaging.
 - Frequency resolution of 5% or better of the critical bandwidth.
 - Hanning time window with at least 67% overlap.
 - Total averaging time of 1 minute.
- 3.46 The tone assessment procedure has three main steps:
- Analyse the noise at the receiver location using FFT.
 - Determine the sound pressure level of the tone(s) and the sound pressure level of the masking noise within the critical band.
 - From the difference between tone and masking level, determine audibility and consequently the tonal penalty.
- 3.47 The JNM2 analysis method produces the tonal audibility, ΔL_{ta} expressed in dB above the masking threshold, (MT). The penalty correction to reflect the tonality, k is the value to be added to the value of L_{Aeq} for the noise source to give the tone-corrected rating level.

4.0 Overall Analysis

4.1 The results from the ten individual measurements across the nine sites have been collated in order to provide an overall assessment of results prior to the site by site analysis.

Sound Pressure Level

4.2 Table 4-1 presents the typical measured noise level from each ASHP when operating under normal conditions. The measured data is set against the manufacturers' noise data provided for the unit.

4.3 It should be noted that the 8.0 kW Manufacturer B ASHPs have two speed settings. From the results, it is clear that these units were operating on the higher setting level.

Table 4-1: Typical Sound Pressure Level Results $L_{Aeq(1min)}$ dB @ 1m from unit (in line with fan)

Site Code	ASHP Description	Manufacturers' SPL Data	Typical Site Measured L_{Aeq} level	Difference
		20 50 80	20 50 80 -5 0 5	
478	8.5 kW Manufacturer A	53	55	+2
479	8.5 kW Manufacturer A	53	56	+3
422	8.0 kW Manufacturer B	58	56	0
422	6.0 kW Manufacturer B	51	47	-4
418	8.0 kW Manufacturer B	58	57	0
443	8.2 kW Manufacturer C	64	64	0
440	9.0 kW Manufacturer D	-	61	0
474	9.1 kW Manufacturer E	57	60	+3
475	5.5 kW Manufacturer E	57	62	+5
486	8.0 kW Manufacturer F	49	54	+5

- 4.4 Table 4-1 indicates a close correlation between the manufacturers' data and the measured site levels with the exception of the units at sites 474 and 475.
- 4.5 Of the site measured levels, the ASHP at Site 443 is the loudest of the units with that at Site 422 (6.0 kW) being the quietest and the only one which recorded a noise level below the manufacturers noise levels. The range in noise levels was substantial at 17 dB which subjectively corresponds to approximately a quadrupling in noise level.

Tonal Analysis

- 4.6 Perceived noise pollution is not simply a factor of how loud the noise level is, but it is also affected by the noise characteristics such as tonality and how often the noise occurs (intermittency).
- 4.7 Table 4-2 presents the JNM2 tone corrected rating level for each ASHP when operating under normal conditions.

Table 4-2: Tone Corrected Rating Level dBA				
Site Code	ASHP Description	Typical Site Measured L_{Aeq} level	Tonal Penalty, k	Tone Corrected Rating Level
		20 50 80	0 3 6	20 50 80
478	8.5 kW Manufacturer A	55	0	55
479	8.5 kW Manufacturer A	56	1	57
422	8.0 kW Manufacturer B	56	5	61
422	6.0 kW Manufacturer B	47	6	53
418	8.0 kW Manufacturer B	57	2	59
443	8.2 kW Manufacturer C	64	4	68
440	9.0 kW Manufacturer D	61	2	63
474	9.1 kW Manufacturer E	60	0	60
475	5.5 kW Manufacturer E	62	2	64
486	8.0 kW Manufacturer F	54	3	57

- 4.8 Table 4-2 indicates Sites 478 & 479 have low tonal noise (“manufacturer A”) while site 422 (manufacturer B) has high tonal noise. Note, however, that there is a second example of a site with an ASHP by manufacturer B with a lower tonal component.

Distance Attenuation

- 4.9 The distance at which the noise level from each of the measured ASHPs is reduced to below the facade level of L_{Aeq} 45 dB (L_{Aeq} 42 dB ignoring the facade effect) has been calculated using Equation 1. The resulting distances are given in Table 4-3, for noise levels both with and without tonal correction. The calculation assumes that the ASHP is located in the common mounting scenario i.e. at ground level against a wall and over hard ground.
- 4.10 The distances quoted are based on free field attenuation. Where there is an intervening barrier such as a fence or building the required minimum separation distances from the neighbouring property would be reduced. However, where the unit was located in a reflective environment causing a ‘canyon’ effect, such as an alleyway the separation distances may need to be increased.

Table 4-3: Distance from unit at which noise level would be L_{Aeq} 42 dB (m) (free field)

Site Code	ASHP Description	Without tonal correction	With tonal correction
		0 25 50	0 25 50
478	8.5 kW Manufacturer A	9	9
479	8.5 kW Manufacturer A	10	11
422	8.0 kW Manufacturer B	10	18
422	6.0 kW Manufacturer B	4	8
418	8.0 kW Manufacturer B	11	14
443	8.2 kW Manufacturer C	28	45
440	9.0 kW Manufacturer D	16	20
474	9.1 kW Manufacturer E	16	16
475	5.5 kW Manufacturer E	20	25
486	8.0 kW Manufacturer F	8	11

- 4.11 The impact of the tonal correction is significant on some of the ASHP acceptable separation distances, such as Manufacturer ‘C’ where the distance is increased to 45 m. This distance would make installation difficult in an urban environment and as such could have implications on the commercial potential of such products.
- 4.12 The majority of the units require a separation distance of between 10 and 20m, which limits their potential use on flatted developments. If Manufacturer ‘B’s 6.0 kW unit could be re-engineered to reduce the tonal components the separation distance of 4m could be acceptable in a flatted environment.

Dose Value

- 4.13 It was noted that the ASHPs used in the trials all cycle on and off at different regularities and periods. Table 4-4 below presents the typical ASHP operating noise level L_{Aeq} , time corrected over the whole measurement period. This therefore represents a factor of both how loud the noise was but also how long the unit was active during the week long measurements. Also presented for comparison is the typical ASHP noise level when operating.

**Table 4-4: Typical Sound Pressure Levels @ 1m from front of unit
(dB re 2×10^{-5} Pa) with dose values**

Site Code	ASHP Description	Typical Site	
		Measured L_{Aeq} level	L_{Aeq} , time-corrected
478	8.5 kW Manufacturer A	55	54
479	8.5 kW Manufacturer A	56	54
422	8.0 kW Manufacturer B	56	51
422	6.0 kW Manufacturer B	47	42
418	8.0 kW Manufacturer B	57	56
443	8.2 kW Manufacturer C	64	58
440	9.0 kW Manufacturer D	61	55
474	9.1 kW Manufacturer E	60	52
475	5.5 kW Manufacturer E	62	57
486	8.0 kW Manufacturer F	54	48

- 4.14 It is interesting to note that whilst sites 422 and 418 had similar noise levels of the same units, the overall noise dose from site 422 was significantly less as a result of the lower overall operating time.
- 4.15 Manufacturer 'A' ASHP which was the least tonal was identified as being most constant in operation.

Defrost Cycle

- 4.16 As the defrost cycle typically presents a different noise signature for the normal operational noise of the ASHP, the defrost cycle noise level has been isolated and analysed separately. For three of the units the defrost cycle could not be identified. This was either due to the absence of a defrost cycle or the cycle presenting similar noise characteristic to the normal operation.
- 4.17 The requirement for defrost cycles is understood to be dependent on the ambient humidity conditions as well as temperature (to a lesser extent). The approximate frequency of occurrence and duration of defrost cycles for each ASHP during the measurements is given in Table 4-5.

Table 4-5: ASHP defrost cycle occurrence and duration

Site Code	ASHP Description	Approx. occurrence	Approx. duration
478	8.5 kW Manufacturer A	-	-
479	8.5 kW Manufacturer A	-	-
422	8.0 kW Manufacturer B	~8 hours	3-4 mins
422	6.0 kW Manufacturer B	~4 hours	1-2 mins
418	8.0 kW Manufacturer B	~3 hours	3-4 mins
443	8.2 kW Manufacturer C	~2 hours	2-3 mins
440	9.0 kW Manufacturer D	~8 hours	3-4 mins
474	9.1 kW Manufacturer E	~2 hours	1-2 mins
475	5.5 kW Manufacturer E	~8 hours	2-3 mins
486	8.0 kW Manufacturer F	-	-

4.18 Table 4-6 presents the measured noise level during the defrost cycle together with the calculated tonal correction according to JNM2.

Table 4-6: Defrost Cycle Typical and Tone Corrected Rating Level dBA				
Site Code	ASHP Description	Typical Site	Tonal Penalty, k	Tone Corrected
		Measured L_{Aeq} level		Rating Level
		20 50 80		20 50 80
478	8.5 kW Manufacturer A	-	-	-
479	8.5 kW Manufacturer A	-	-	-
422	8.0 kW Manufacturer B	54	6	60
422	6.0 kW Manufacturer B	50	6	56
418	8.0 kW Manufacturer B	52	6	58
443	8.2 kW Manufacturer C	57	6	63
440	9.0 kW Manufacturer D	59	6	65
474	9.1 kW Manufacturer E	51	6	57
475	5.5 kW Manufacturer E	63	6	69
486	8.0 kW Manufacturer F	-	-	-

4.19 For the majority of ASHPs the defrost cycle noise level is lower than the normal operating noise level.

4.20 Table 4-6 indicates that all the ASHP defrost cycles attract the maximum (6 dB) tonal penalty. This is in some cases due to the increased noise from the compressor, but in the majority due to the reduced masking noise as a result of the fan turning off. The tone corrected level for the defrost cycle can be seen to be higher than the normal tone corrected operating level on sites 422 (6.0 kW), 440 and 475.

Sound Power Level

4.21 Table 4-7 presents the typical measured sound power level from each ASHP when operating under normal conditions. The measured data is set against the manufacturers' sound power level data provided for the unit.

Table 4-7: Typical Sound Power Level SWL dBA					
Site Code	ASHP Description	Manufacturers' SWL Data	Typical Site Measured L_{WA} level	Difference	
478	8.5 kW Manufacturer A	65	66	+1	
479	8.5 kW Manufacturer A	65	67	+2	
422	8.0 kW Manufacturer B	64	67	+3	
422	6.0 kW Manufacturer B	57	59	+2	
418	8.0 kW Manufacturer B	64	68	+4	
443	8.2 kW Manufacturer C	72	76	+4	
440	9.0 kW Manufacturer D	65	71	+6	
474	9.1 kW Manufacturer E	65	71	+6	
475	5.5 kW Manufacturer E	65	73	+8	
486	8.0 kW Manufacturer F	62	65	+3	

4.22 Table 4-7 indicates that the measured sound power level correlates well (± 5 dB) with the majority of manufacturers with the exception of Manufacturers 'D' and 'E'.

4.23 The measured sound power levels are generally higher than the manufacturers' laboratory data. This is likely to be due to a number of factors, such as the calculation procedure not fully accounting for the level of reflections experienced on site. Other factors will be differences in measurement methods and the units tested in lab are likely to be in perfect operating condition.

5.0 Site Analysis

5.1 *486 Stroud*

Site description

- 5.1.1. The property is located in a small town off a quiet road. The ASHP is located to the rear of the brick built two story terraced property. The unit is mounted onto the wall surface at first floor level, supported from a metal frame fixed to the brickwork. Vibration isolation couplings were used between the unit and the framework.
- 5.1.2. Subjectively the unit appeared to be operating normally with no audible rattle, resonance or fault.

Equipment set up

- 5.1.3. The 9 Channel PULSE system was used at this site.
- 5.1.4. Unlike the other eight sites there was no reflective ground immediately below the unit, although the ASHP was seated on a solid shelf.
- 5.1.5. Accelerometers were fixed to the unit casing and to the wall surface immediately behind the unit, as shown in Picture 5-1 and Picture 5-2. The accelerometers were fixed to the surfaces using cyanoacrylate cement.

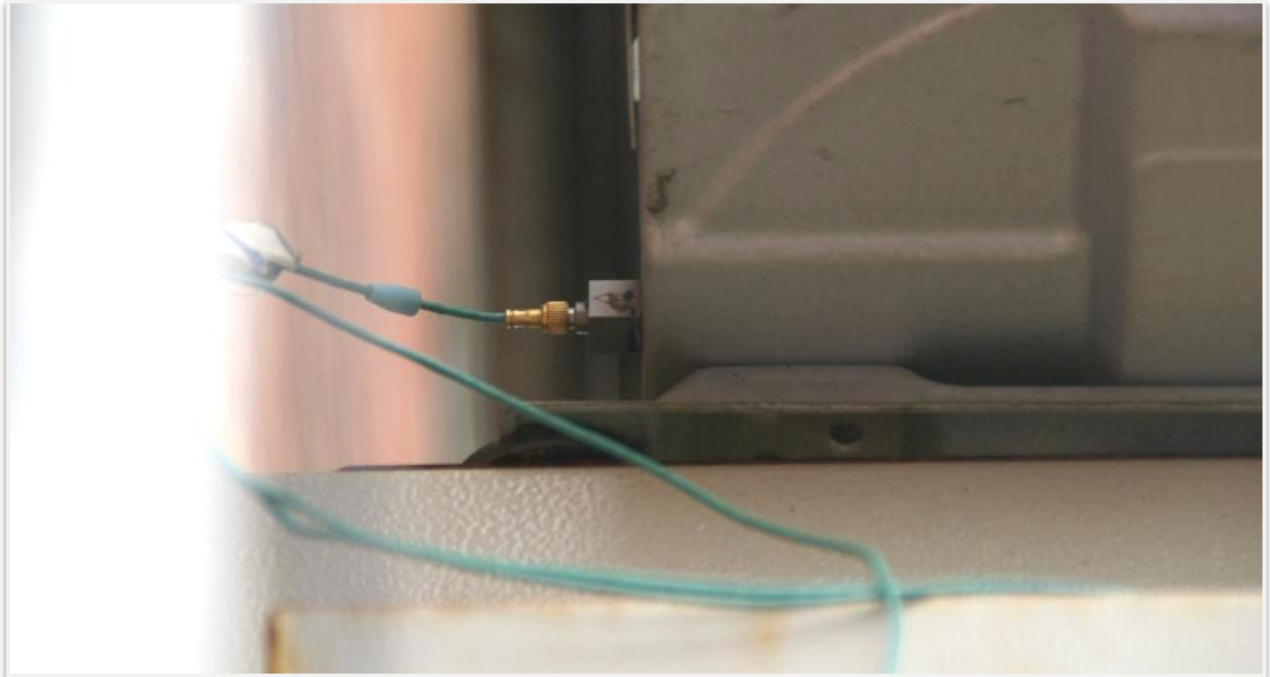

Picture 5-1. 486 Stroud, Casing-mounted Accelerometer



Picture 5-2. 486 Stroud, Wall-mounted Accelerometer

5.1.6. The microphones were mounted on a temporary scaffolding framework as shown in Picture 5-3 and Picture 5-4. All microphones were positioned 1 m from the ASHP casing except the top position, which was located at 600 mm due to height constraints.



Picture 5-3. 486 Stroud, ASHP and Microphone Arrangement



Picture 5-4. 486 Stroud, ASHP and Microphone Arrangement

Measurement Results

5.1.7. Figure 5-1 presents the $L_{Aeq(1min)}$ measured noise levels at the microphone 1m in front of the unit set against time, along with the per-minute logged ASHP power consumption.

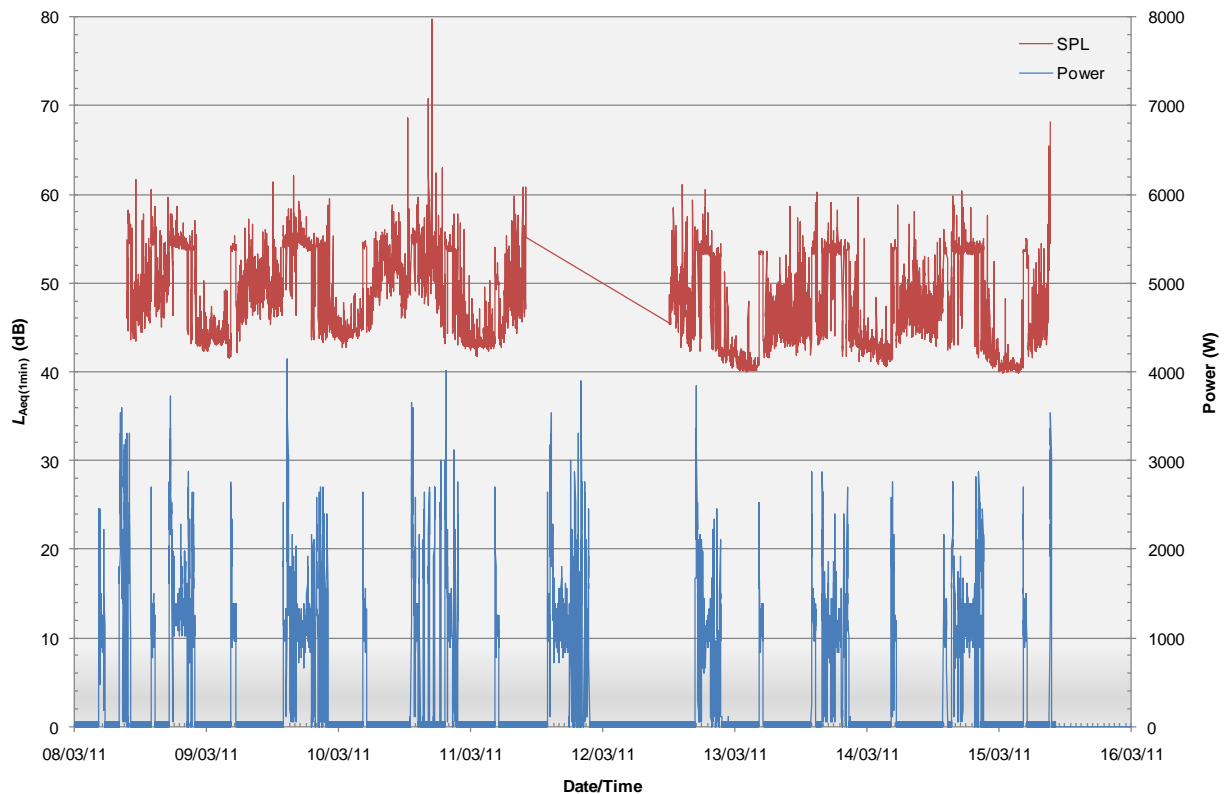

Figure 5-1. 486 Stroud, Sound Pressure Level and Power Consumption vs Time

- 5.1.8. The PULSE system stopped recording on the 12th March and was reset on the 13th March
- 5.1.9. The chart highlights that the ASHP is cycling on and off approximately every twelve hours, for approximately six hours then for an hour. Throughout the measurement period, the ASHP was operational for approximately 22% of the time.
- 5.1.10. The trace clearly shows the increase in measured noise level during periods when the ASHP is operating.

Measurement Analysis

5.1.11. Figure 5-2 presents a scatter diagram showing the noise levels against the power consumption, for the periods when the ASHP was operating. The chart trend line indicates a slight increase in noise level with ASHP power level, although the fit is not conclusive, with a regression coefficient (r^2) of only 5%.

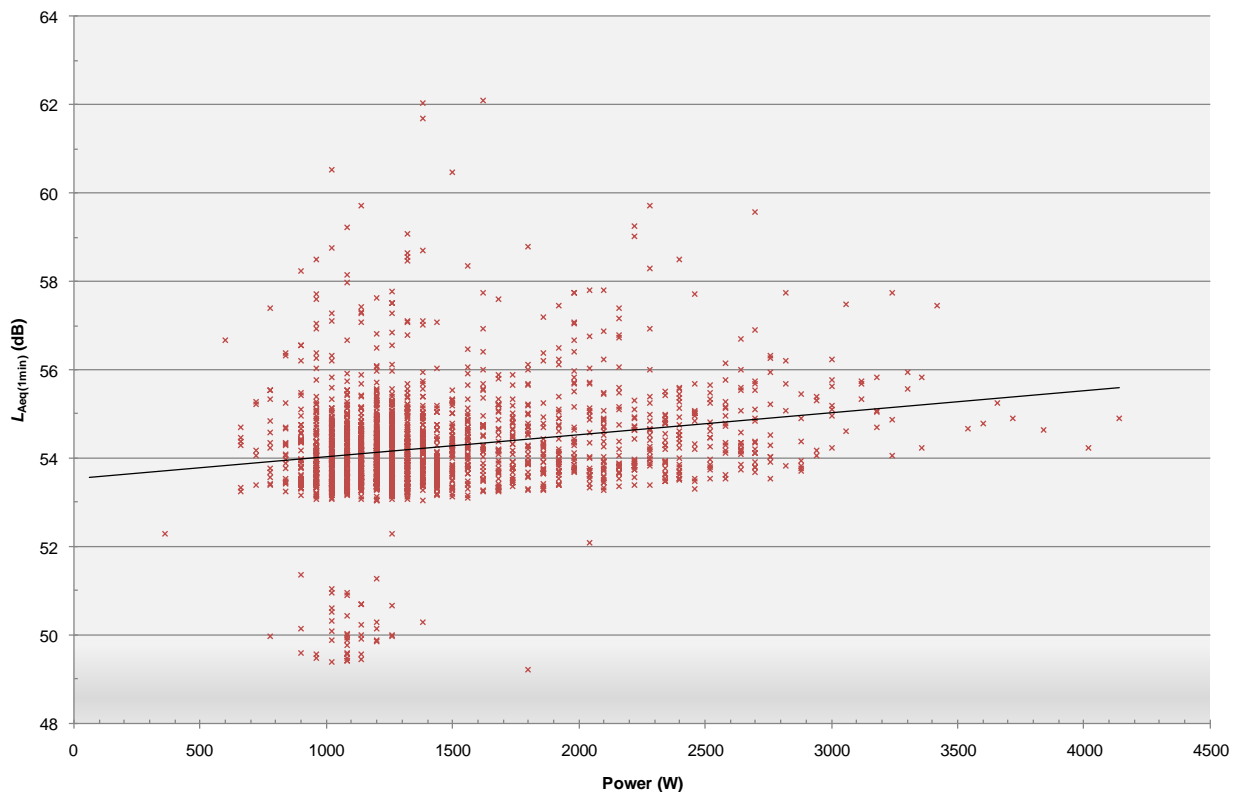

Figure 5-2. 486 Stroud, Sound Pressure Level vs Power Consumption

5.1.12. Given that there is no clear relationship between power use and noise output it is unlikely that there is any relationship between ambient temperature and noise level. To confirm this Figure 5-3 presents a scatter diagram showing the noise levels against the ambient temperature, for the periods when the ASHP was operating. Whilst the chart trend line displays a slight increase in noise level with ambient temperature, it can be seen that the data is not a conclusive fit, with a regression coefficient (r^2) of only 5%. An additional scatter chart of power use against ambient temperature in Figure 5-4 also shows that there is no clear link between these parameters.

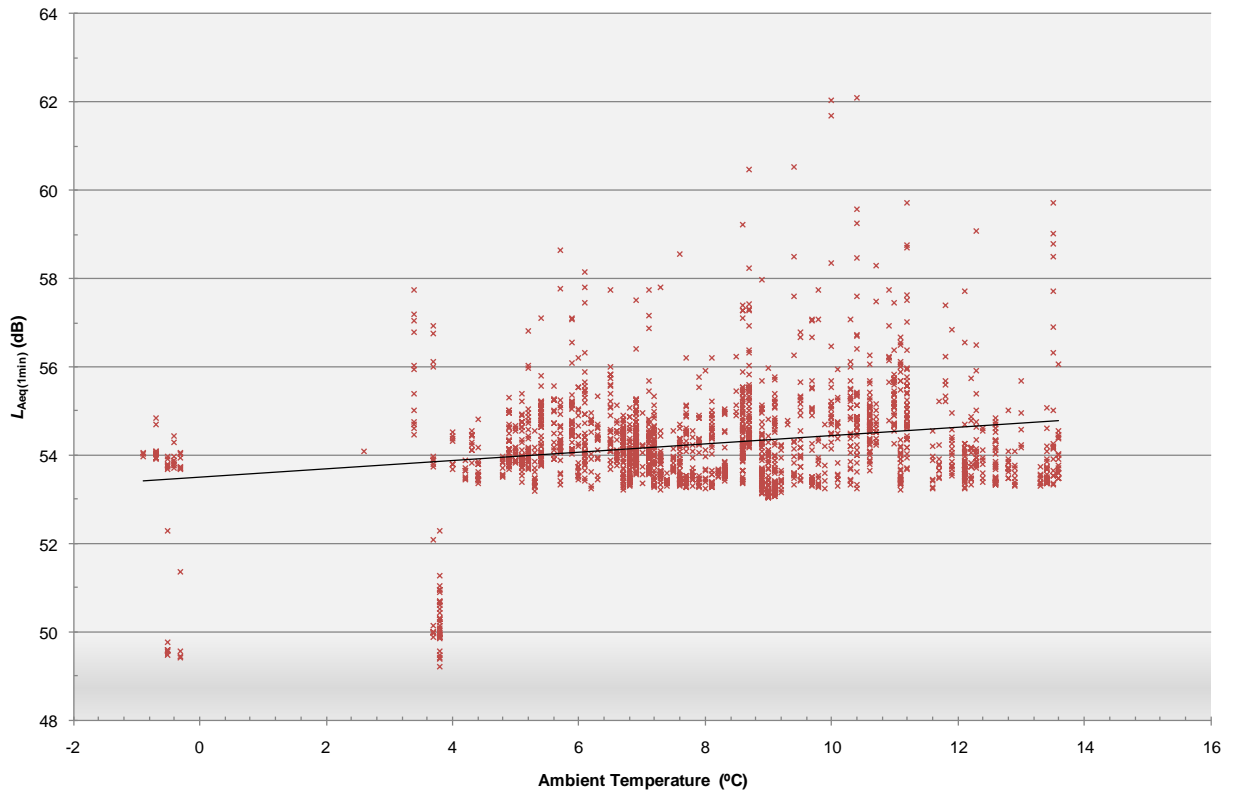

Figure 5-3. 486 Stroud, Sound Pressure Level vs Ambient Temperature

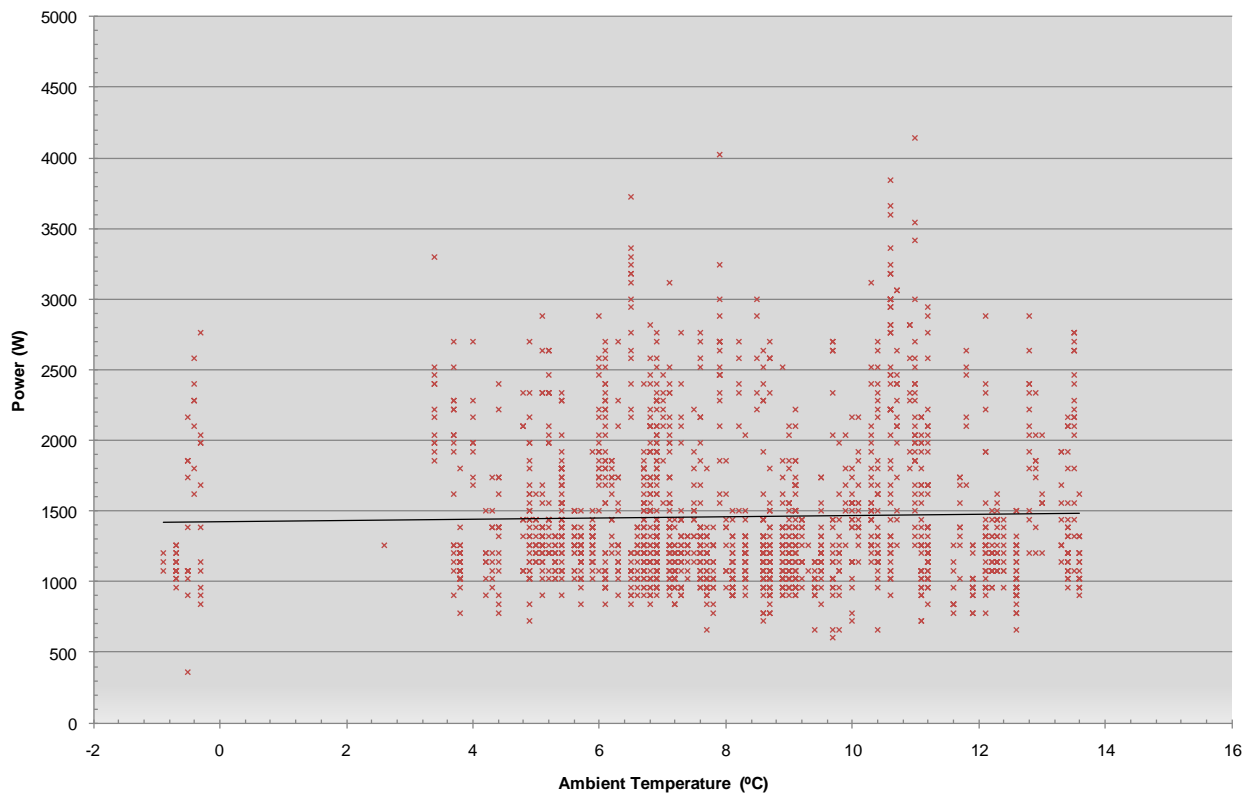

Figure 5-4. 486 Stroud, Power Consumption vs Ambient Temperature

- 5.1.13. Given the lack of relationship for power or temperature with noise, or each other, for the rest of the sites only the power vs noise scatter charts have been presented.
- 5.1.14. Figure 5-5 presents a statistical analysis plot of the percentage of time that a specific noise level would be recorded, when the ASHP is under operation. From this confidence intervals can be presented for the typical noise levels.

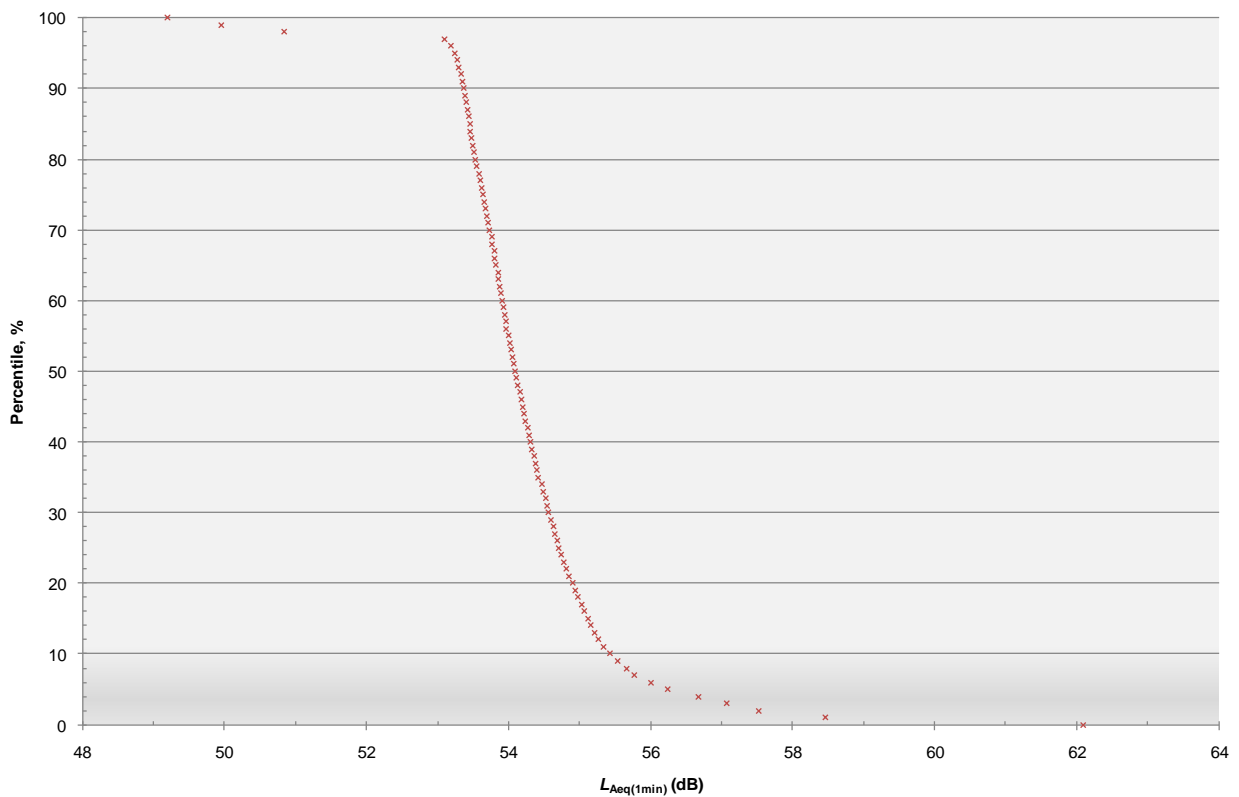

Figure 5-5. 486 Stroud, Sound Pressure Level Statistical Analysis

- 5.1.15. The chart indicates that noise from the ASHP during operation will have a 90% certainty of being within around 1.5 dB of $L_{Aeq(1min)}$ **54 dB**. The corresponding total ASHP noise dose over the whole assessment period is calculated as $L_{Aeq,1week}$ 48 dB.

Defrost Cycle

- 5.1.16. Analysis of the measurements failed to identify defrost cycles with any certainty. Whilst certain short periods of operation were revealed within the measurement data, the analysis has shown the noise to be very similar to that of a 'normal' operating condition. It is therefore likely that either no defrost cycles occurred during the measurements or that the sound characteristic during the defrost cycle is similar to that during normal operation.

Directivity

- 5.1.17. Table 5-1 shows the directivity in noise emissions from the unit by comparing the noise levels at the different microphones, for a typical period of ASHP operation.

Table 5-1: Directivity Analysis of the ASHP Noise Emissions $L_{Aeq(1min)}$ dB 486 Stroud, normal operation				
Microphone Location	Front	Left	Right	Above
Typical Microphone Level	54	53	52	54
Change from front microphone	-	-1	-2	0

- 5.1.18. It is seen that the ASHP does not exhibit a significant directivity, which is deemed to be attributed to the presence of nearby reflective surfaces at this site.

Frequency analysis

- 5.1.19. For the frequency analysis, a Fast Fourier Transform (FFT) of the signal was performed, averaged over a representative one minute period at a frequency resolution of 2 Hz. The resulting frequency spectrum for the ASHP operating under normal conditions is given in Figure 5-6.

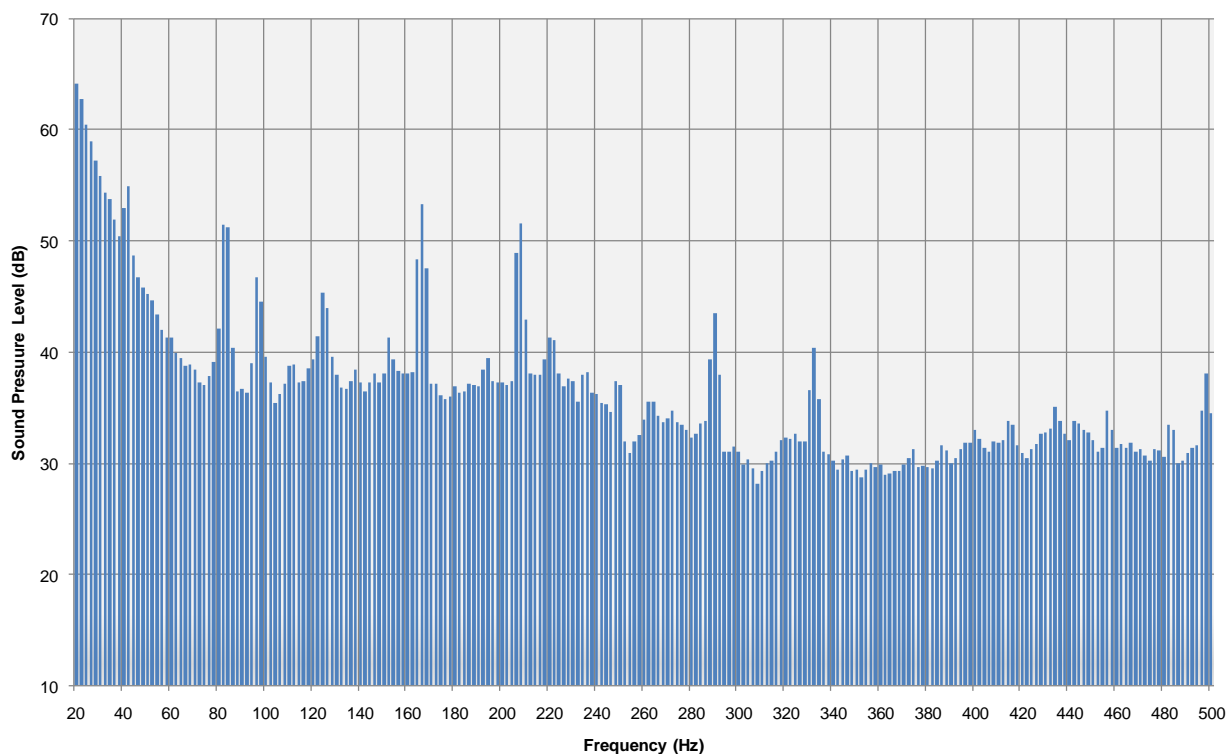
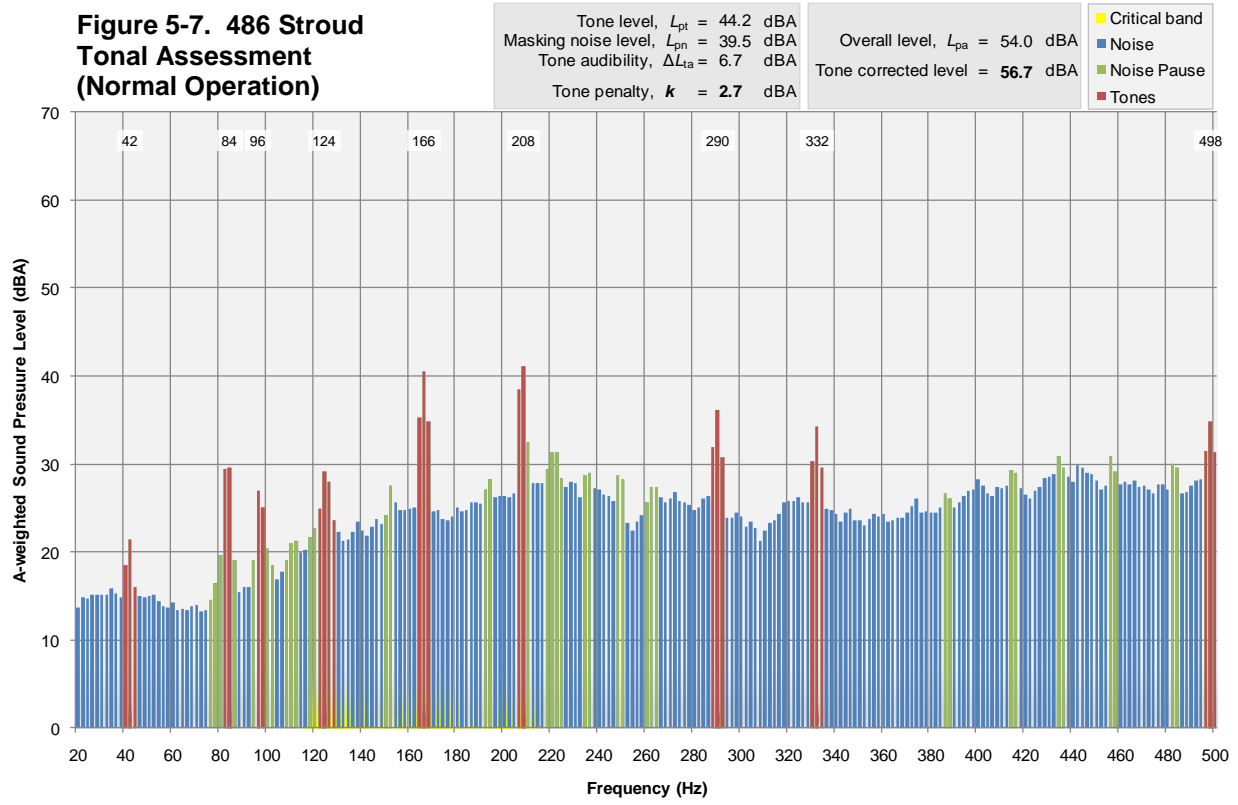

Figure 5-6. 486 Stroud, Sound Pressure Level Frequency Spectrum (Normal Operation)

5.1.20. Tonal analysis of the frequency spectrum shown in Figure 5-6 has been undertaken in accordance with the Joint Nordic Method (v2). The resulting tonal assessment is presented in Figure 5-7, showing that the tones identified within the spectrum would lead to a **3 dB tonal penalty**.



Sound Power Level calculations

5.1.21. Figure 5-8 presents a statistical analysis plot of the percentage of time that a specific sound power level would be recorded, when the ASHP is under operation.

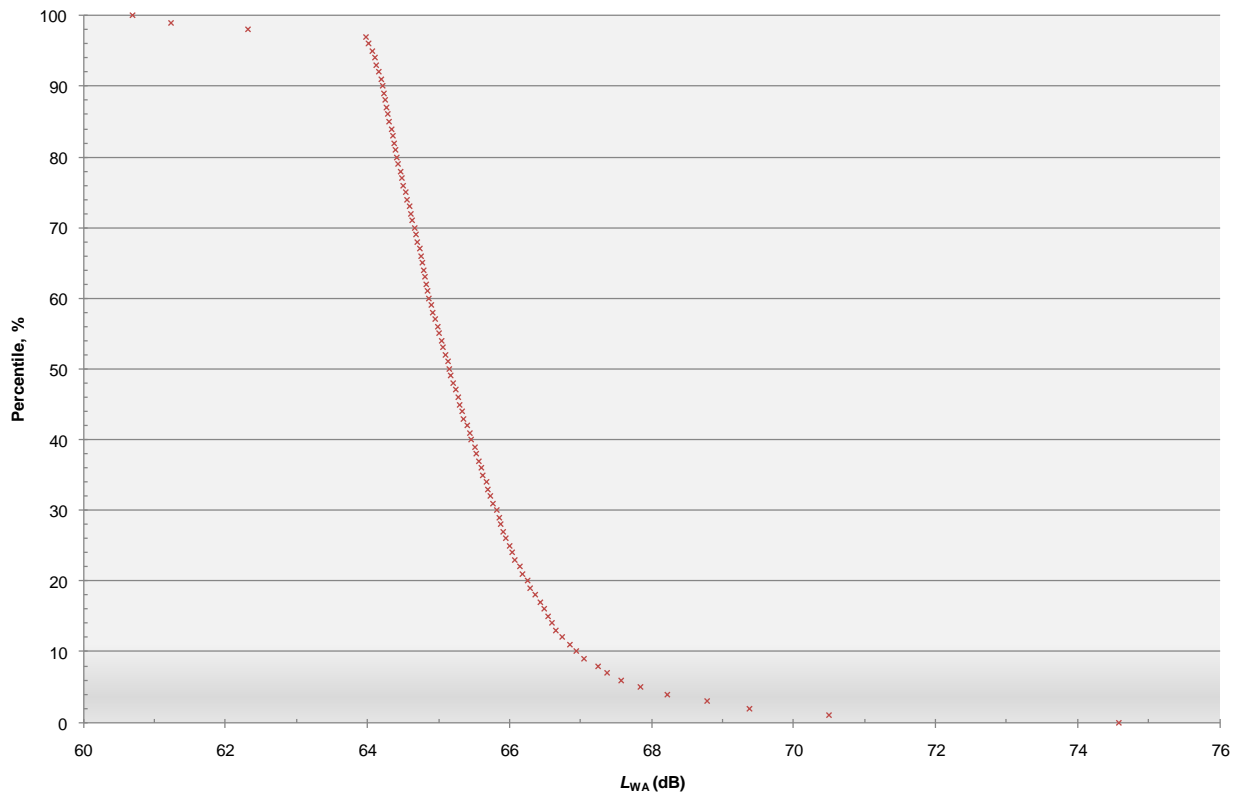

Figure 5-8. 486 Stroud, Sound Power Level Statistical Analysis

- 5.1.22. The chart indicates that noise from the ASHP during operation will have a 90% certainty of being within around 1.5 dB of L_{WA} 65 dB.
- 5.1.23. Use of Equation 1 leads to an estimation that noise levels from the unit operating normally would drop to L_{Aeq} 42 dB at a distance separation of approximately **8 m**. If a tonal penalty were to be included, then this distance would rise to around **11 m**. This assumes that the ASHP is located in the common mounting scenario as detailed in Section 3.41, which is not necessarily representative of the actual measured condition.

Vibration

- 5.1.24. An FFT analysis of the vibration levels recorded for normal operation of the ASHP is shown in Figure 5-9. The overall weighted peak vibration level at the wall surface was 0.0053 ms^{-2} , below the average perception threshold for whole-body vibration.

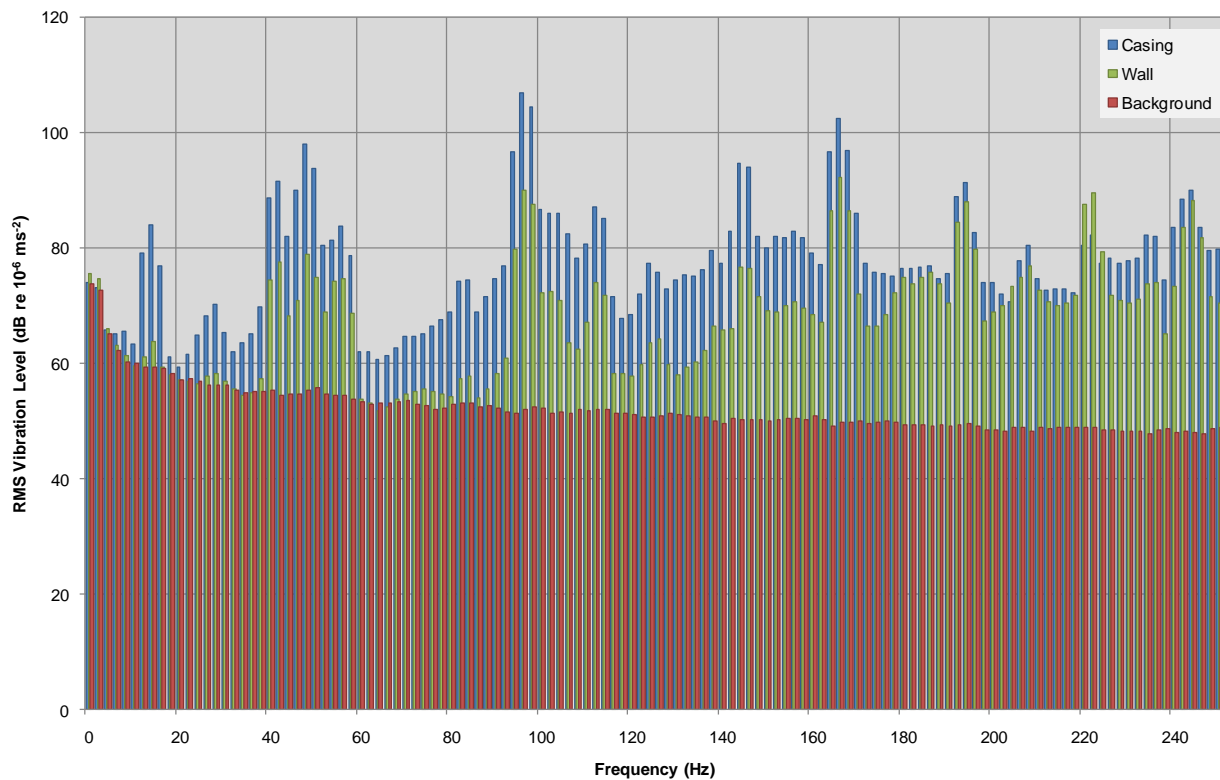

Figure 5-9. 486 Stroud, Vibration Levels

Discussion

- 5.1.25. Data for the rotational speed of the fan and compressor has not been provided for this particular ASHP. However, from experience, it is believed that the rotation of the fan causes the tones identified at 42, 84, 124, 166 and 208 Hz, whilst the compressor causes the tone at 96 Hz. This corresponds with a fan speed of 2520 rpm, and a compressor speed of the order 5760 rpm.
- 5.1.26. The vibration data shows that there is good vibration attenuation between the casing and wall surface, due to the presence of the isolation mounts. There is however a reduction in isolation performance noted around 220 Hz, possibly due to a resonance in the isolation. A reduction in isolation performance at this frequency has the potential to increase noise transmission into the building structure.

5.2 *440 Fylde*

Site description

- 5.2.1. The property is located in a small town off a quiet road. The ASHP is located to the rear of the brick built two story terraced property. The unit is seated on concrete footings, and is bounded by reflective planes to the rear and to one side.
- 5.2.2. Subjectively the unit appeared to be operating normally with no audible rattle, resonance or fault.

Equipment set up

- 5.2.3. The 5 Channel PULSE system was used at this site.
- 5.2.4. The ASHP was located on hard, reflective ground.
- 5.2.5. An accelerometer was fixed to the unit casing, as shown in Picture 5-5 using cyanoacrylate cement.



Picture 5-5. 440 Fylde, Casing-mounted Accelerometer

5.2.6. Two of the microphones were mounted on tripods, with a third microphone mounted on temporary framework as shown in Picture 5-6 and Picture 5-7. All microphones were positioned 1 m from the ASHP casing.



Picture 5-6. 440 Fylde, ASHP and Microphone Arrangement



Picture 5-7. 440 Fylde, ASHP and Microphone Arrangement

Measurement Results

5.2.7. Figure 5-10 presents the $L_{Aeq(1min)}$ measured noise levels at the microphone 1m in front of the unit set against time, along with the per-minute logged ASHP power consumption.

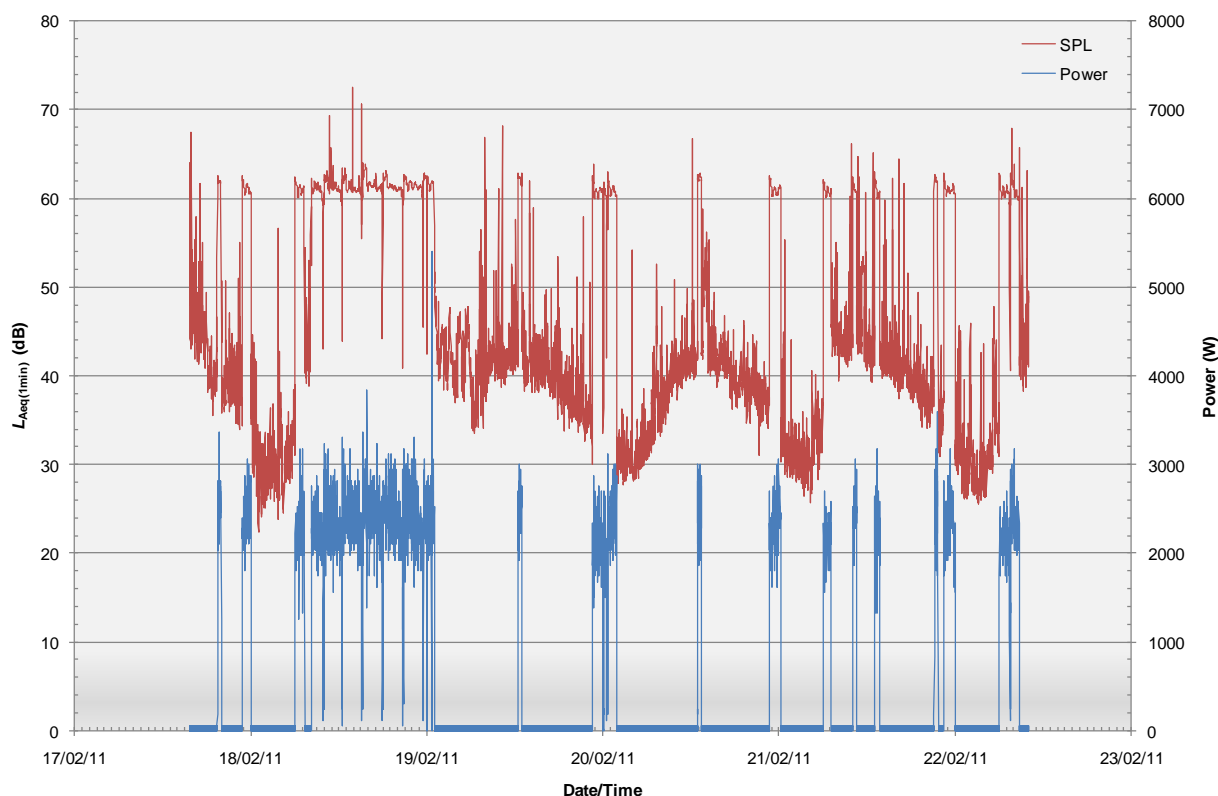

Figure 5-10. 440 Fylde, Sound Pressure Level and Power Consumption vs Time

5.2.8. The chart highlights that the ASHP operates for at least an hour around midday, and two hours around midnight. In addition to the regular operation, the ASHP operates for numerous additional periods, presumably in accordance with the demands of the householder. Throughout the measurement period, the ASHP was operating for approximately 27% of the time.

5.2.9. The trace clearly shows the increase in measured noise level during periods when the ASHP is operating.

Measurement Analysis

5.2.10. Figure 5-11 presents a scatter diagram showing the noise levels against the power consumption, for the periods when the ASHP was operating. The chart trend line indicates a slight increase in noise level with ASHP power level, although the fit is not conclusive, with a regression coefficient (r^2) of 5%.

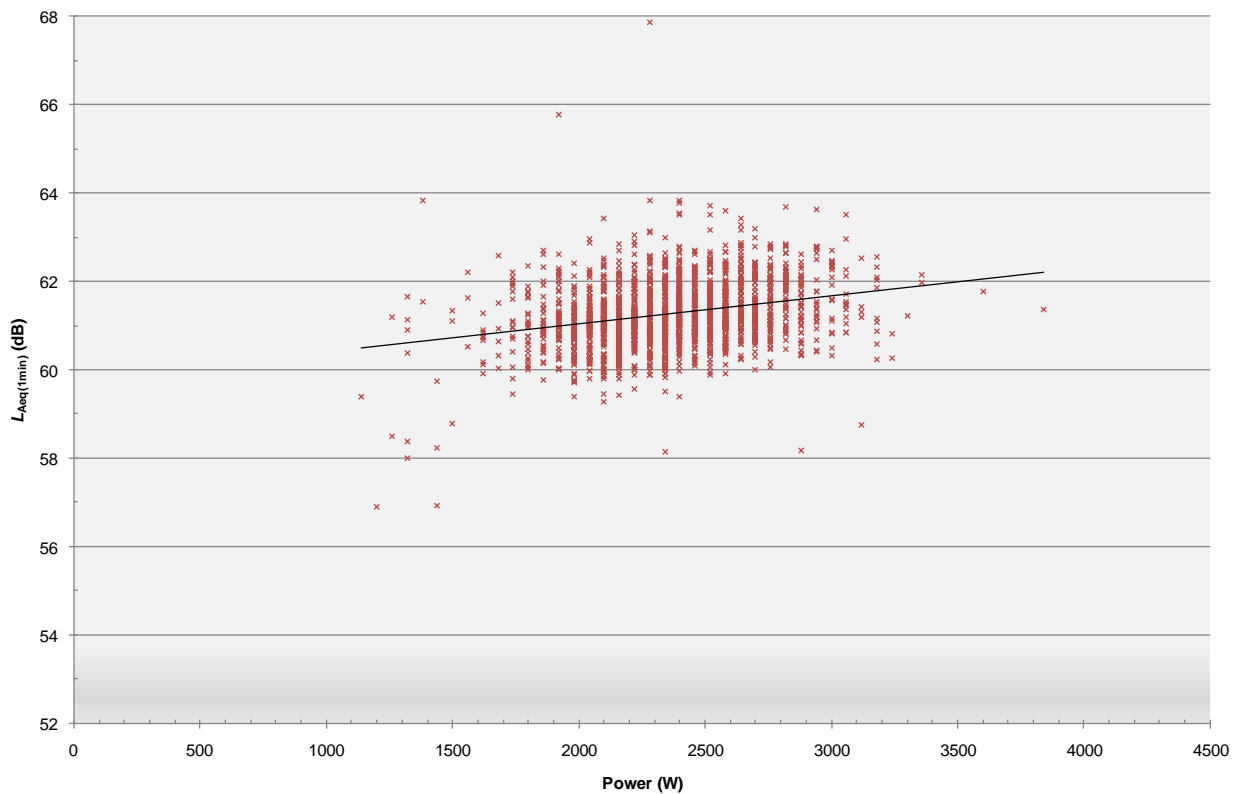

Figure 5-11. 440 Fylde, Sound Pressure Level vs Power Consumption

5.2.11. Figure 5-5 presents a statistical analysis plot of the percentage of time that a specific noise level would be recorded, when the ASHP is under operation. From this confidence intervals can be presented for the typical noise levels.

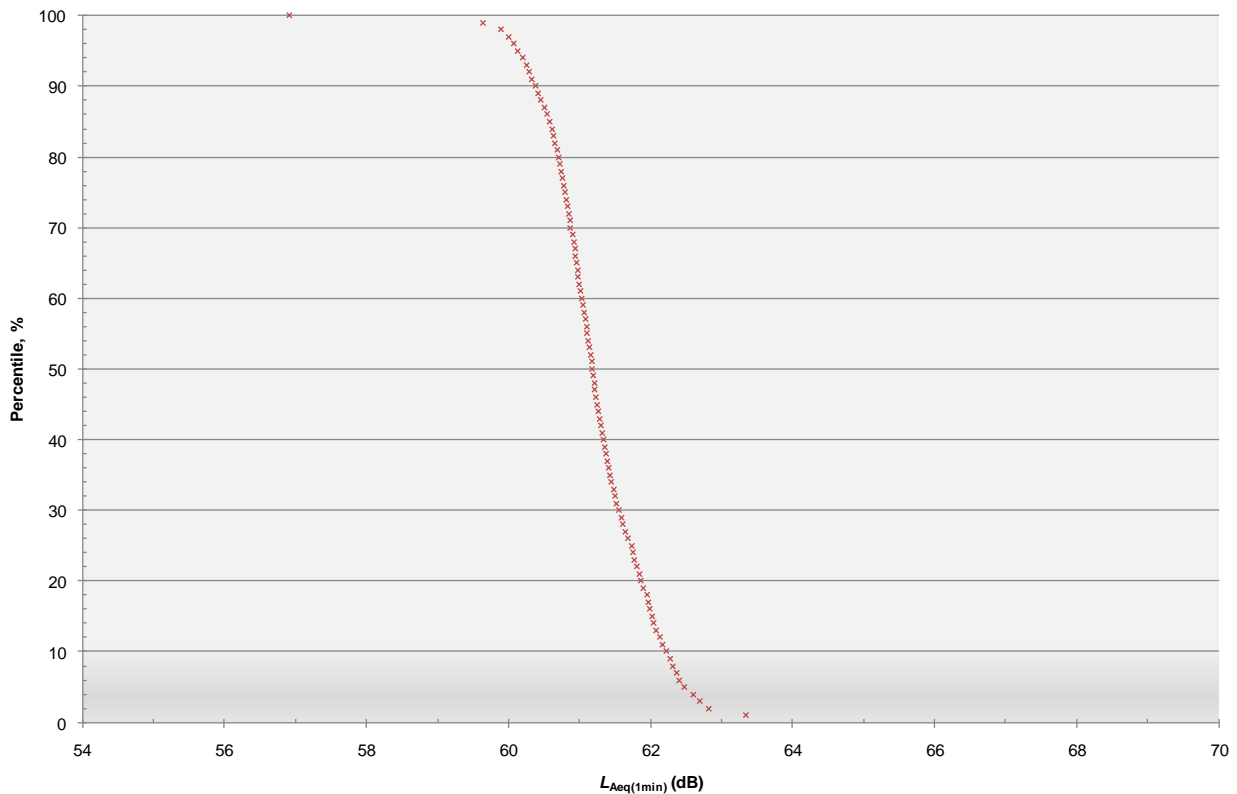

Figure 5-12. 440 Fylde, Sound Pressure Level Statistical Analysis

5.2.12. The chart indicates that noise from the ASHP during operation will have a 90% certainty of being within around 1.5 dB of $L_{Aeq(1min)}$ **61 dB**. The corresponding total ASHP noise dose over the whole assessment period is calculated as $L_{Aeq(1week)}$ **55 dB**.

Defrost Cycle

5.2.13. Analysis of the measurements revealed that defrost cycles are part of the ASHP operation. During these periods, which can last for 3 to 4 minutes, the compressor is operating in reverse, without the fan. The average sound pressure level during a typical defrost cycle is around $L_{Aeq(1min)}$ **59 dB**.

Directivity

- 5.2.14. Table 5-2 shows the directivity in noise emissions from the unit by comparing the noise levels at the different microphones, for a typical period of ASHP operation.

Table 5-2: Directivity Analysis of the ASHP Noise Emissions $L_{Aeq(1min)}$ dB 440 Fylde, normal operation			
Microphone Location	Front	Right	Above
Typical Microphone Level	61	59	59
Change from front microphone	-	-2	-2

- 5.2.15. It is seen that the ASHP is slightly directional to the front of the unit.

Frequency analysis

- 5.2.16. For the frequency analysis, a Fast Fourier Transform (FFT) of the signal was performed, averaged over a representative one minute period at a frequency resolution of 2 Hz. The resulting frequency spectrum for the ASHP operating under normal conditions is given in Figure 5-13, with that for the defrost cycle presented in Figure 5-14.

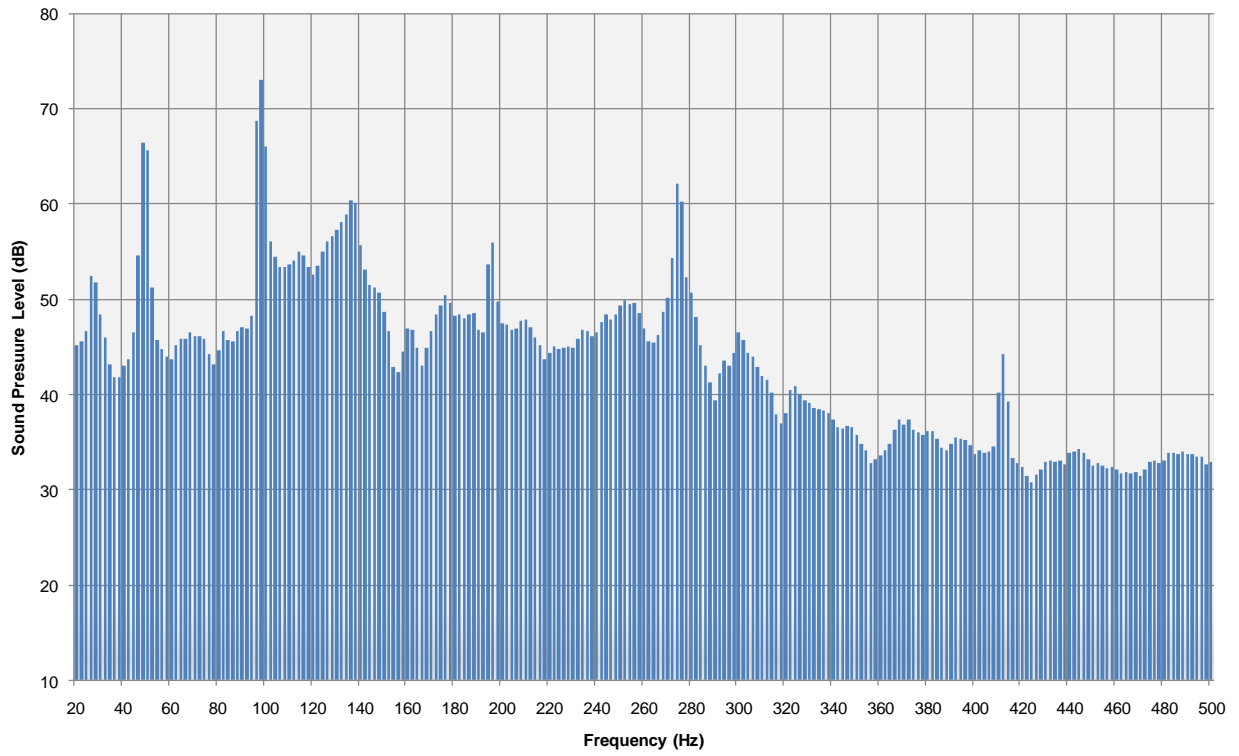

Figure 5-13. 440 Fylde, Sound Pressure Level Frequency Spectrum (Normal Operation)

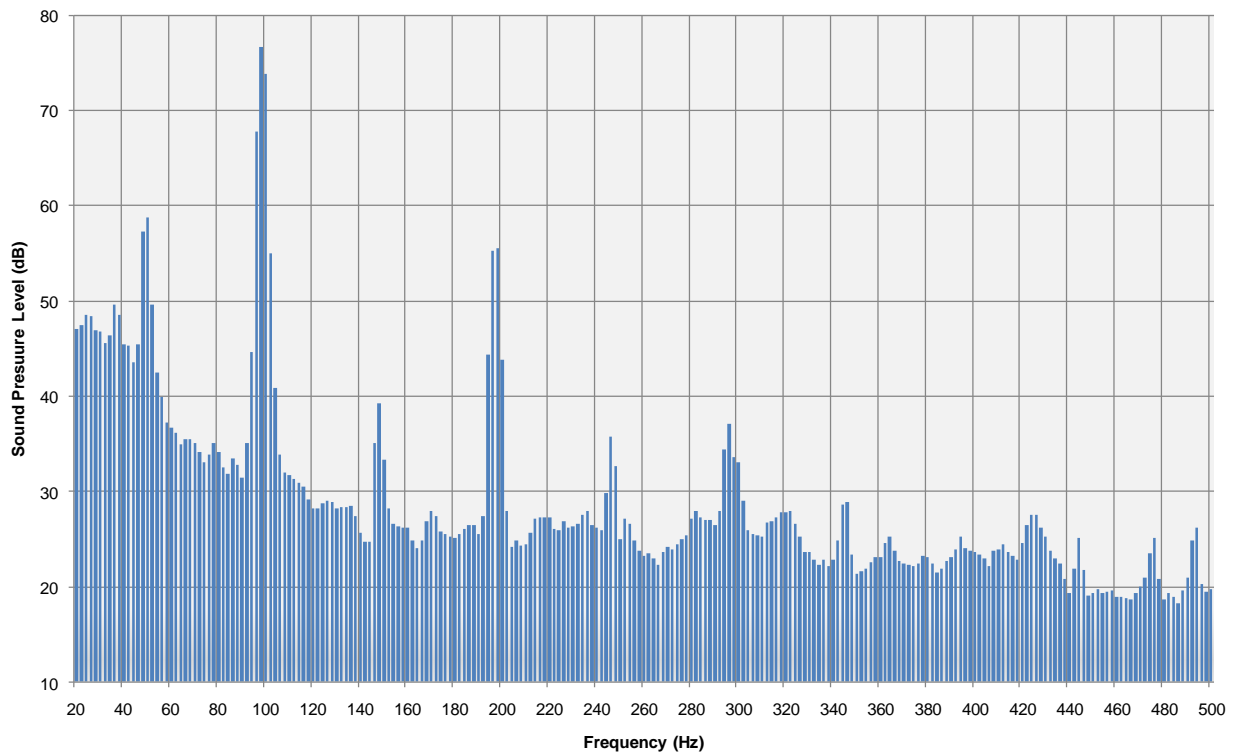
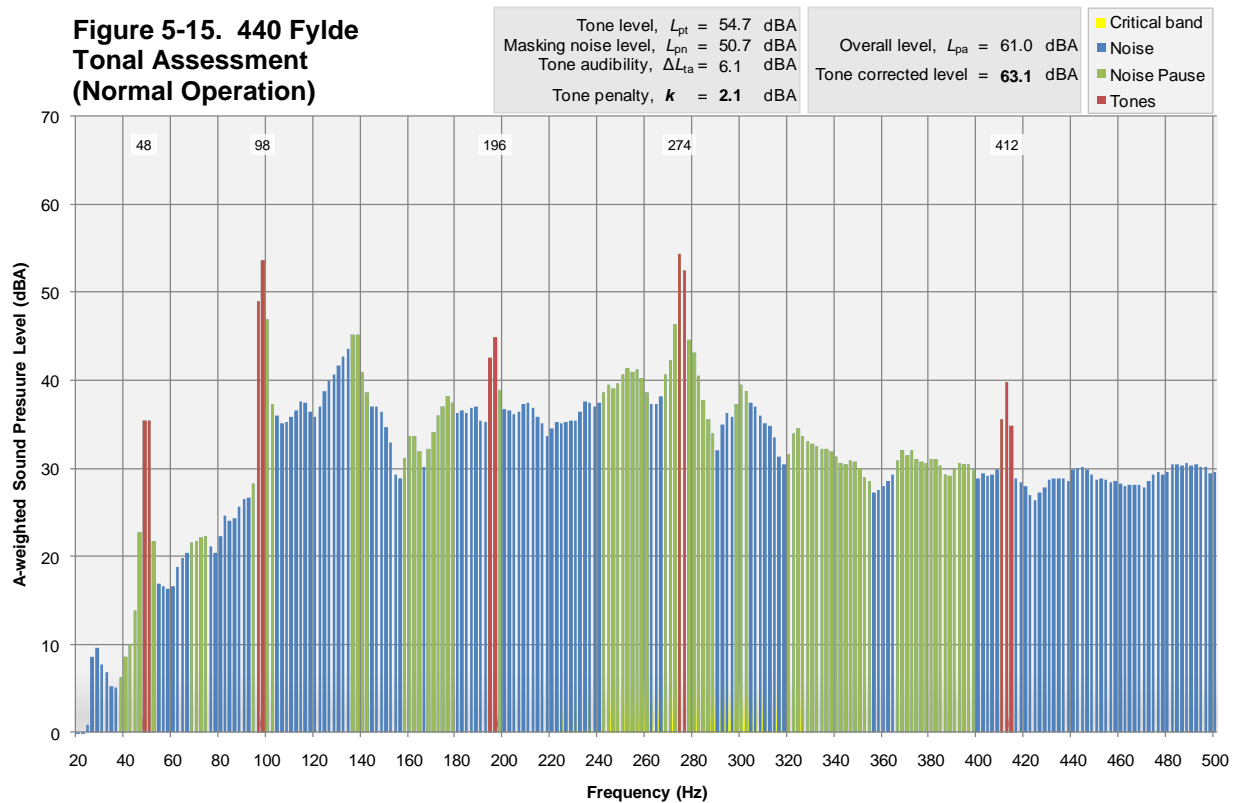
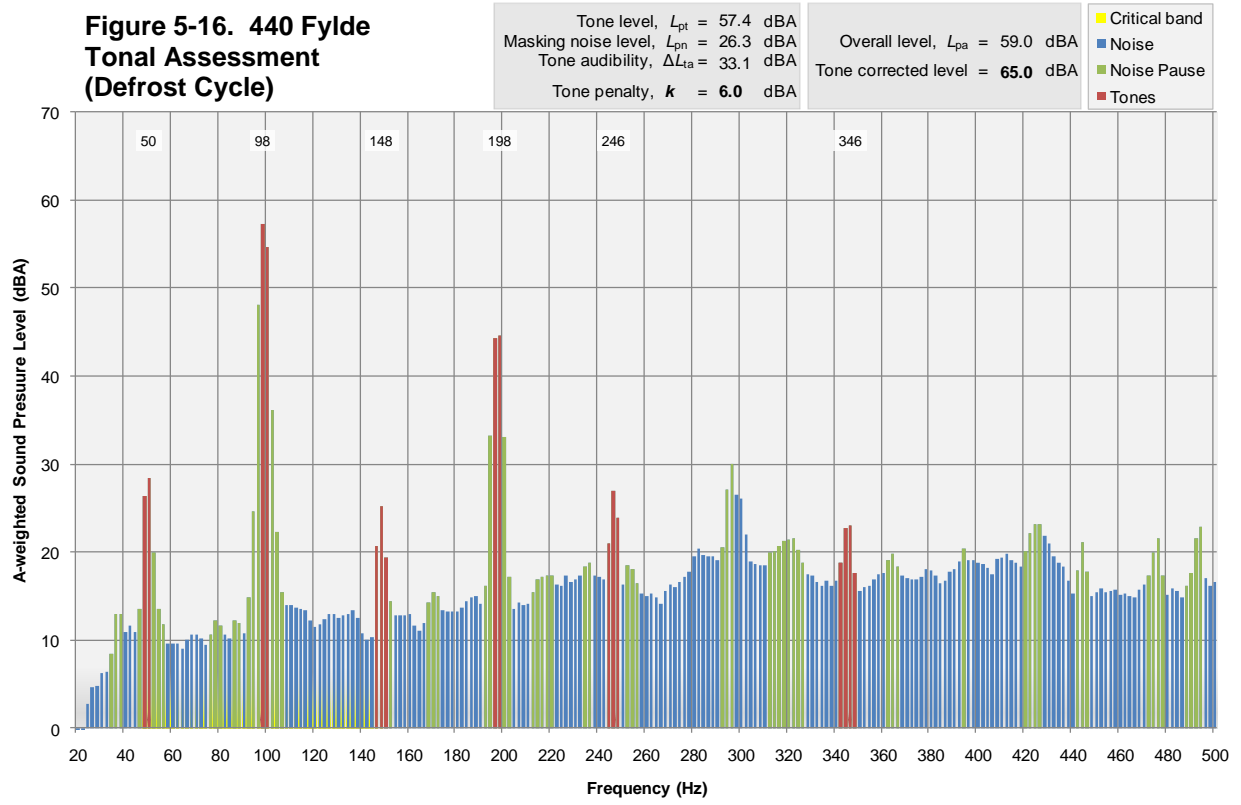

Figure 5-14. 440 Fylde, Sound Pressure Level Frequency Spectrum (Defrost Cycle)

5.2.17. Tonal analysis of the frequency spectra shown in Figure 5-13 and Figure 5-14 has been undertaken in accordance with the Joint Nordic Method (v2). The resulting tonal assessments are presented in Figure 5-16 and Figure 5-16, showing that the tones identified within the spectrum for normal operation would lead to a **2 dB tonal penalty**. During the defrost cycle, the tonal assessment indicates that a **6 dB tonal penalty** would be appropriate.





Sound Power Level calculations

5.2.18. Figure 5-8 presents a statistical analysis plot of the percentage of time that a specific sound power level would be recorded, when the ASHP is under operation.

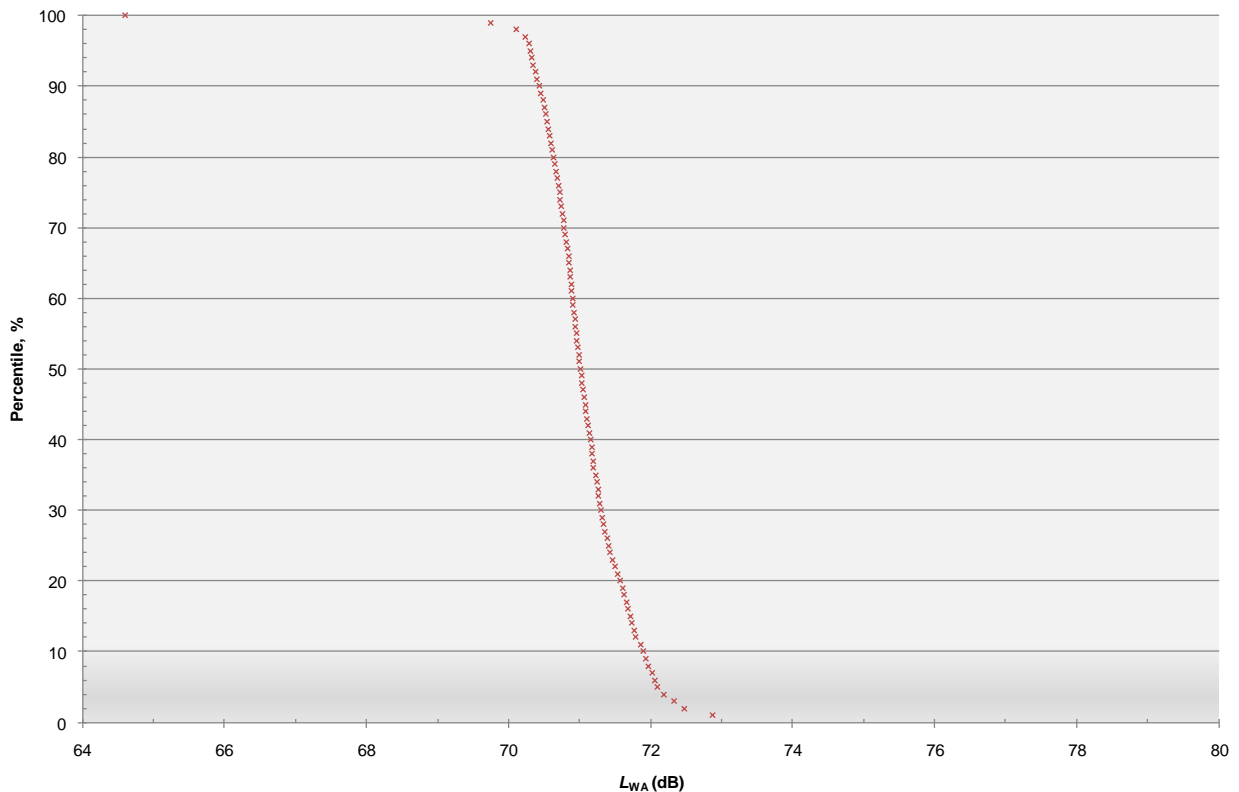

Figure 5-17. 440 Fylde, Sound Power Level Statistical Analysis

- 5.2.19. The chart indicates that noise from the ASHP during operation will have a 90% certainty of being within around 1 dB of L_{WA} **71 dB**.
- 5.2.20. Use of Equation 1 leads to an estimation that noise levels from the unit operating normally would drop to L_{Aeq} 42 dB at a distance separation of approximately **16 m**. If a tonal penalty were to be included, then this distance would rise to around **20 m**. This assumes that the ASHP is located in the common mounting scenario as detailed in Section 3.41, which is not necessarily representative of the actual measured condition.

Vibration

- 5.2.21. An FFT analysis of the vibration levels recorded for normal operation of the ASHP is shown in Figure 5-18.

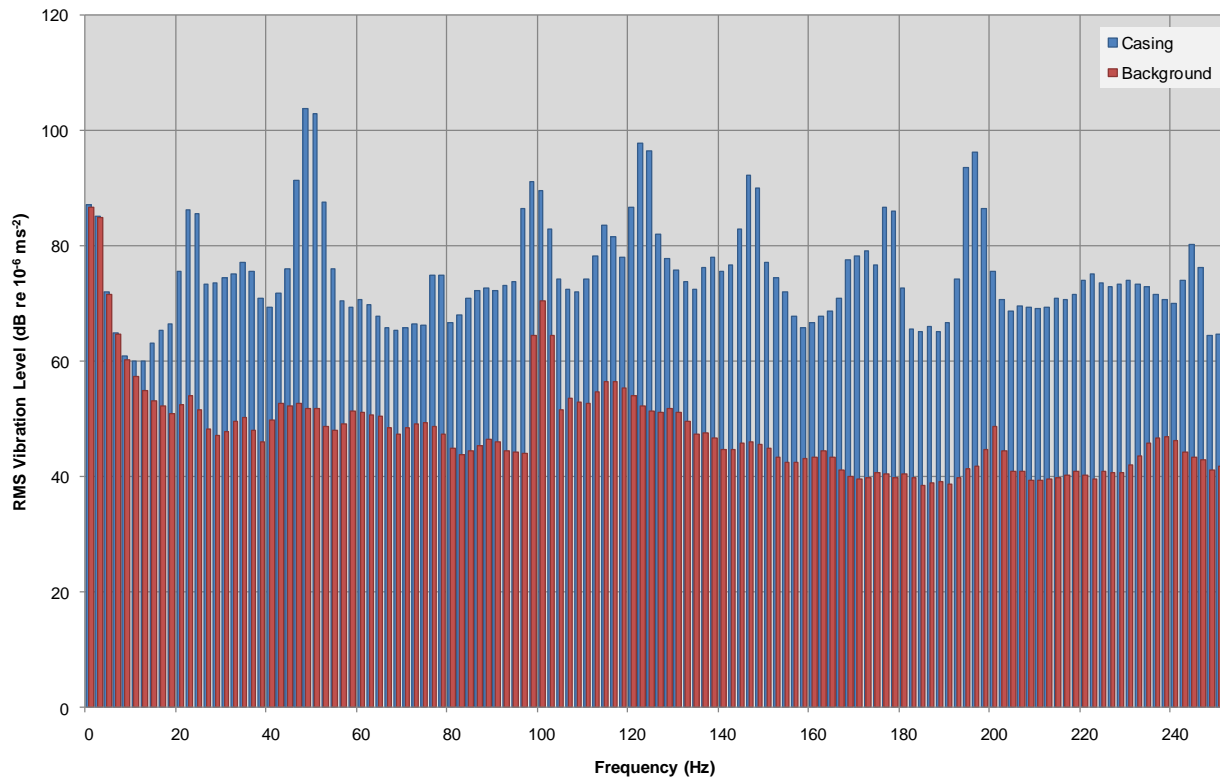

Figure 5-18. 440 Fylde, Vibration Levels

Discussion

- 5.2.22. The manufacturer of the ASHP has disclosed that the fan is of the centrifugal type, with six blades and a rotational speed of 1370 rpm. The compressor is rated with a nominal speed of 1950 rpm. The effects of the compressor can be seen in the frequency analysis of the defrost cycle, where prominent tones can be seen at the primary rotation frequency (~50 Hz) and more importantly at the second and fourth harmonics (~100 Hz). The fan operation causes tones around 140 Hz, 280 Hz and 420 Hz in accordance with the harmonics of the blade passing frequency.
- 5.2.23. During normal operation, the fan and compressor contribute roughly the same amount of noise.
- 5.2.24. The vibration data shows that both the compressor and fan contribute to the vibration emissions.

5.3 **418 Central Buchan**

Site description

- 5.3.1. The property is located in a rural village off a quiet road. The ASHP is located to the rear of a modern brick built single story detached property. The unit is seated on concrete footings, in front of the wall of a separately detached outhouse.
- 5.3.2. Subjectively the unit appeared to be operating normally with no audible rattle, resonance or fault.

Equipment set up

- 5.3.3. The 5 Channel PULSE system was used at this site.
- 5.3.4. The ASHP was located on hard, reflective ground.
- 5.3.5. An accelerometer was fixed to the unit casing, as shown in Picture 5-8, using cyanoacrylate cement. However, subsequent analysis of the results has shown that a representative signal was not present in the data, which could occur, for example, in the event of cable failure. No meaningful vibration data was therefore measured.



Picture 5-8. 418 Central Buchan, Casing-mounted Accelerometer

- 5.3.6. Four microphones were used, mounted on temporary framework as shown in Picture 5-9. All microphones were positioned 1 m from the ASHP casing.



Picture 5-9. 418 Central Buchan, ASHP and Microphone Arrangement

Measurement Results

- 5.3.7. Figure 5-19 presents the $L_{Aeq(1min)}$ measured noise levels at the microphone 1m in front of the unit set against time, along with the per-minute logged ASHP power consumption.

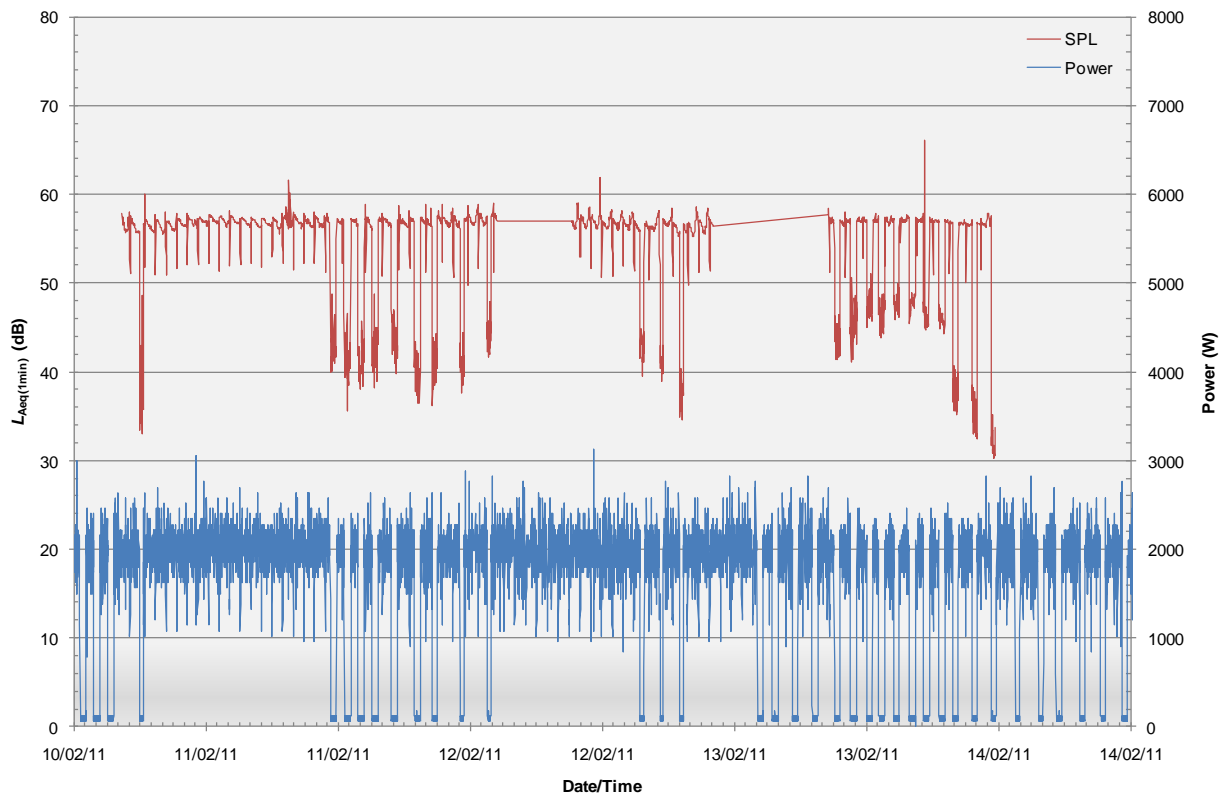

Figure 5-19. 418 Central Buchan, Sound Pressure Level and Power Consumption vs Time

- 5.3.8. The PULSE system stopped recording on two occasions and had to be reset.
- 5.3.9. The chart highlights that the ASHP operates for a large proportion of the time, irrespective of the time of day or night. When the ASHP is seen to switch off, it does so for periods of around 30 minutes. Throughout the measurement period, the ASHP was operating for approximately 80% of the time.
- 5.3.10. The trace clearly shows the increase in measured noise level during periods when the ASHP is operating.

Measurement Analysis

- 5.3.11. Figure 5-20 presents a scatter diagram showing the noise levels against the power consumption, for the periods when the ASHP was operating. The chart trend line indicates a slight increase in noise level with ASHP power level, although the fit is not conclusive, with a regression coefficient (r^2) of 22%.

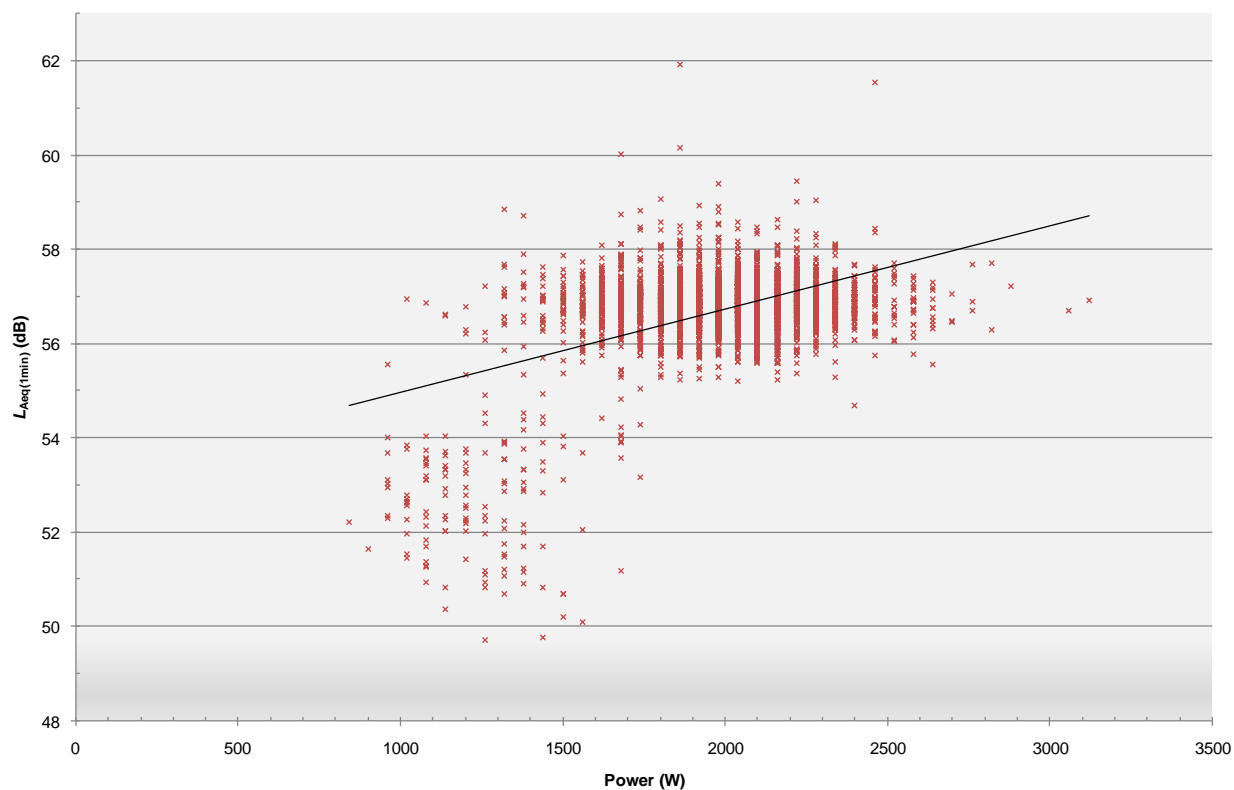

Figure 5-20. 418 Central Buchan, Sound Pressure Level vs Power Consumption

5.3.12. Figure 5-21 presents a statistical analysis plot of the percentage of time that a specific noise level would be recorded, when the ASHP is under operation. From this confidence intervals can be presented for the typical noise levels.

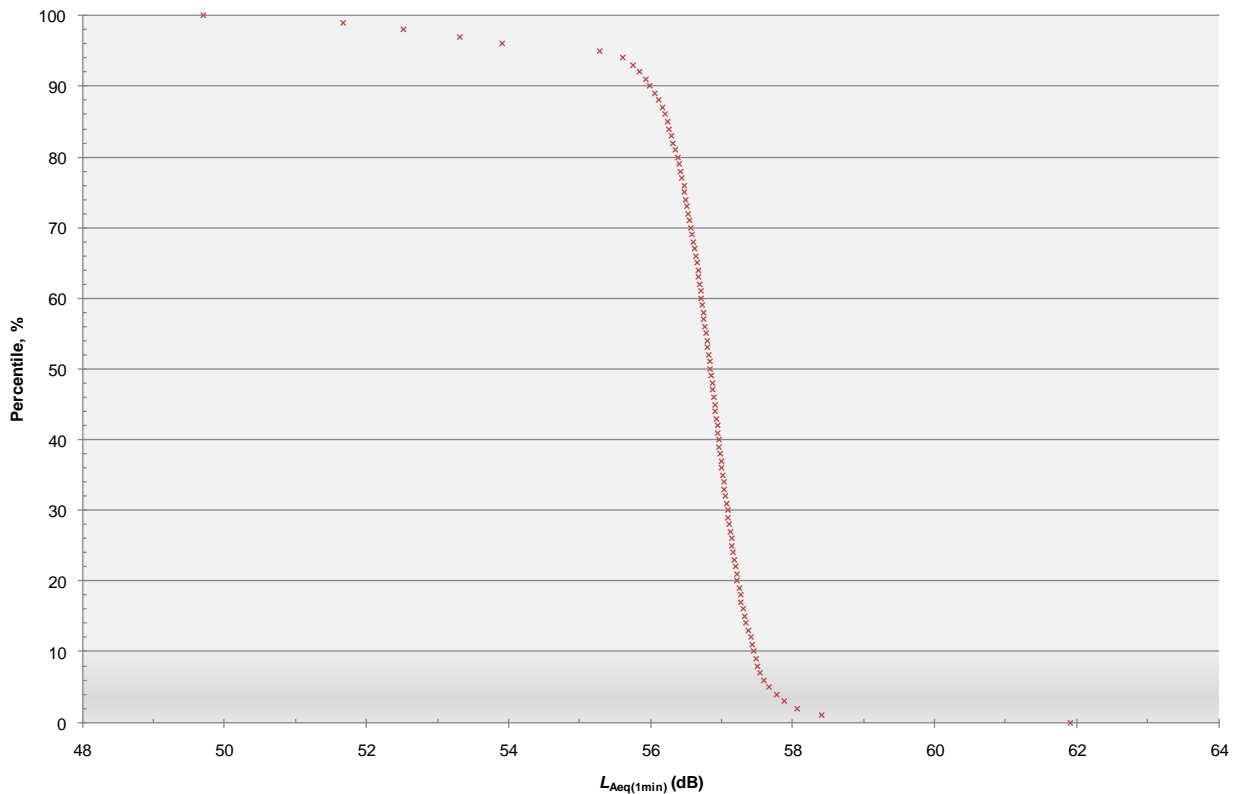

Figure 5-21. 418 Central Buchan, Sound Pressure Level Statistical Analysis

5.3.13. The chart indicates that noise from the ASHP during operation will have a 90% certainty of being within around 1.5 dB of $L_{Aeq(1min)}$ **57 dB**. The corresponding total ASHP noise dose over the whole assessment period is calculated as $L_{Aeq(1week)}$ **56 dB**.

Defrost Cycle

5.3.14. Analysis of the measurements revealed that defrost cycles are part of the ASHP operation. During these periods, which can last for 3 to 4 minutes, the compressor is operating in reverse, without the fan. The average sound pressure level during a typical defrost cycle is around $L_{Aeq(1min)}$ **52 dB**.

Directivity

5.3.15. Table 5-3 shows the directivity in noise emissions from the unit by comparing the noise levels at the different microphones, for a typical period of ASHP operation.

Table 5-3: Directivity Analysis of the ASHP Noise Emissions $L_{Aeq(1min)}$ dB 418 Central Buchan, normal operation				
Microphone Location	Front	Left	Right	Above
Typical Microphone Level	57	55	56	54
Change from front microphone	-	-2	-1	-3

5.3.16. It is seen that the ASHP is slightly directional to the front of the unit.

Frequency analysis

5.3.17. For the frequency analysis, a Fast Fourier Transform (FFT) of the signal was performed, averaged over a representative one minute period at a frequency resolution of 2 Hz. The resulting frequency spectrum for the ASHP operating under normal conditions is given in Figure 5-22, with that for the defrost cycle presented in Figure 5-23.

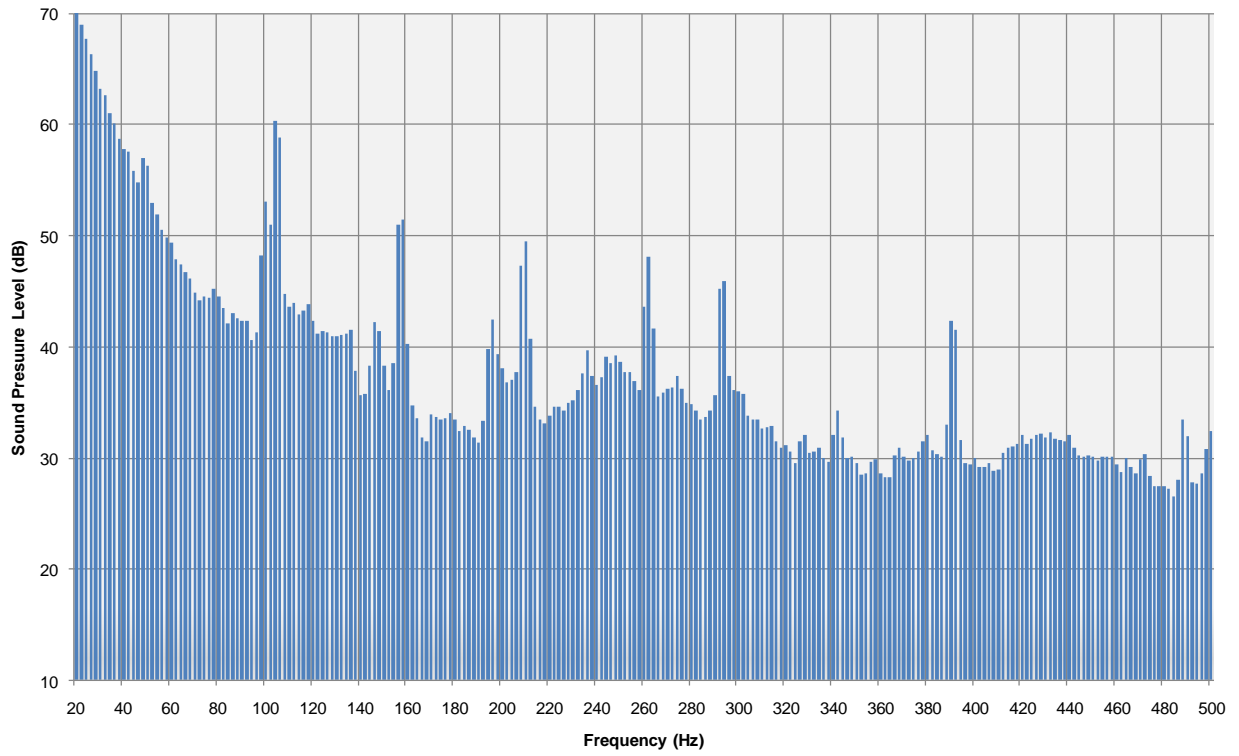

Figure 5-22. 418 Central Buchan, Sound Pressure Level Spectrum (Normal Operation)

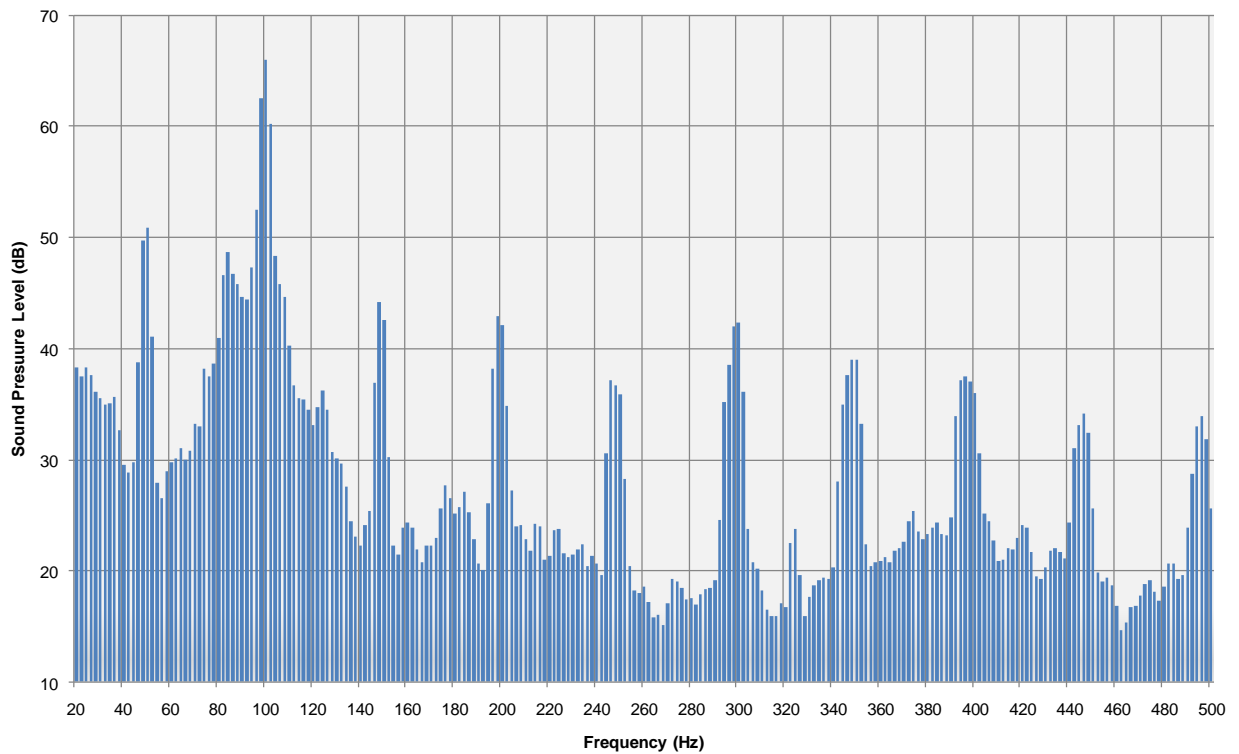
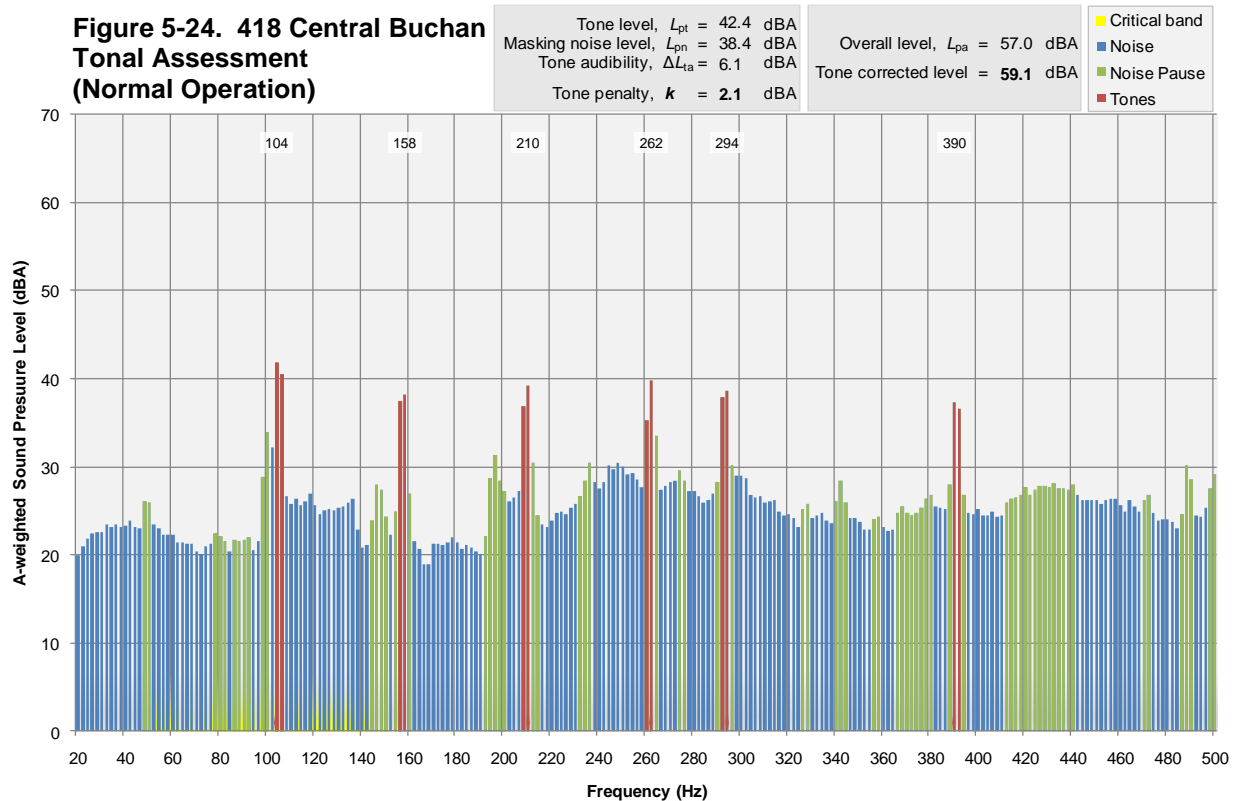
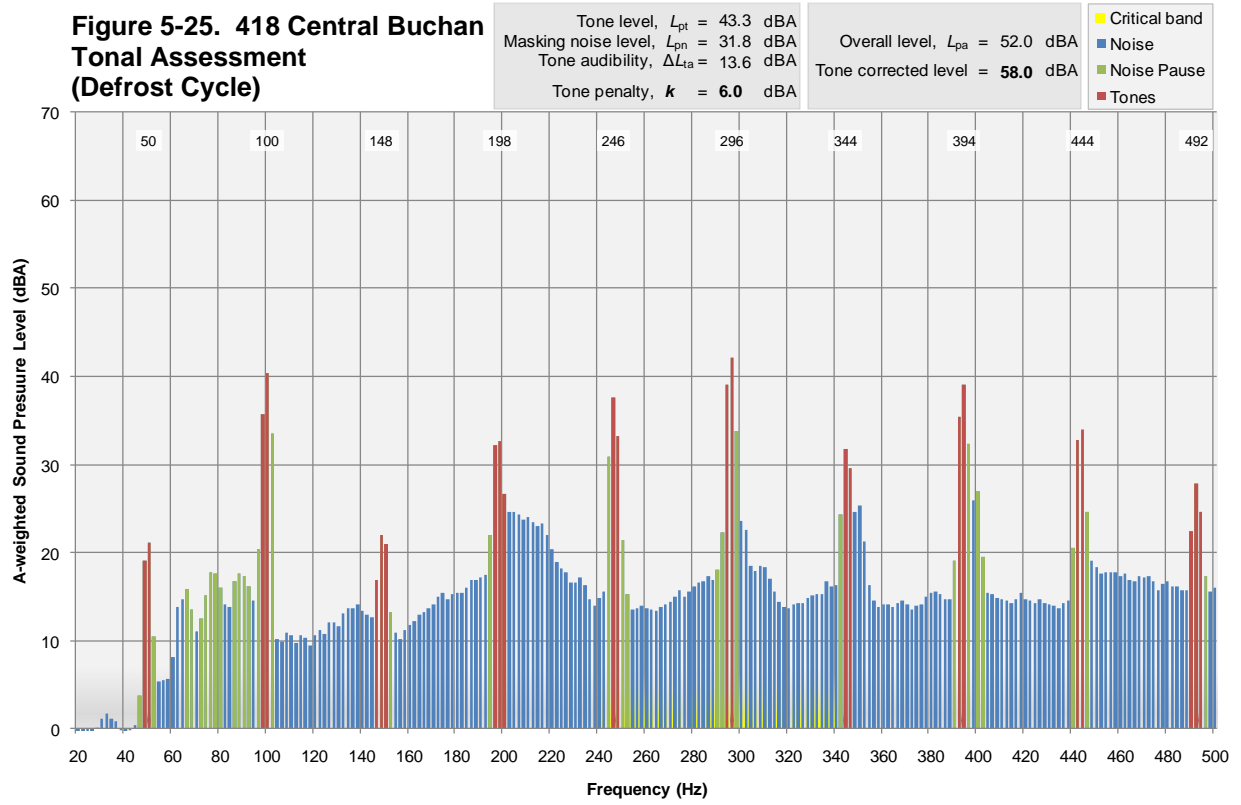

Figure 5-23. 418 Central Buchan, Sound Pressure Level Spectrum (Defrost Cycle)

5.3.18. Tonal analysis of the frequency spectra shown in Figure 5-22 and Figure 5-23 has been undertaken in accordance with the Joint Nordic Method (v2). The resulting tonal assessments are presented in Figure 5-24 and Figure 5-25, showing that the tones identified within the spectrum for normal operation would lead to a **2 dB tonal penalty**. During the defrost cycle, the tonal assessment indicates that a **6 dB tonal penalty** would be appropriate.





Sound Power Level calculations

5.3.19. Figure 5-8 presents a statistical analysis plot of the percentage of time that a specific sound power level would be recorded, when the ASHP is under operation. This assumes that the ASHP is located in the common mounting scenario as detailed in Section 3.41, which is not necessarily representative of the actual measured condition.

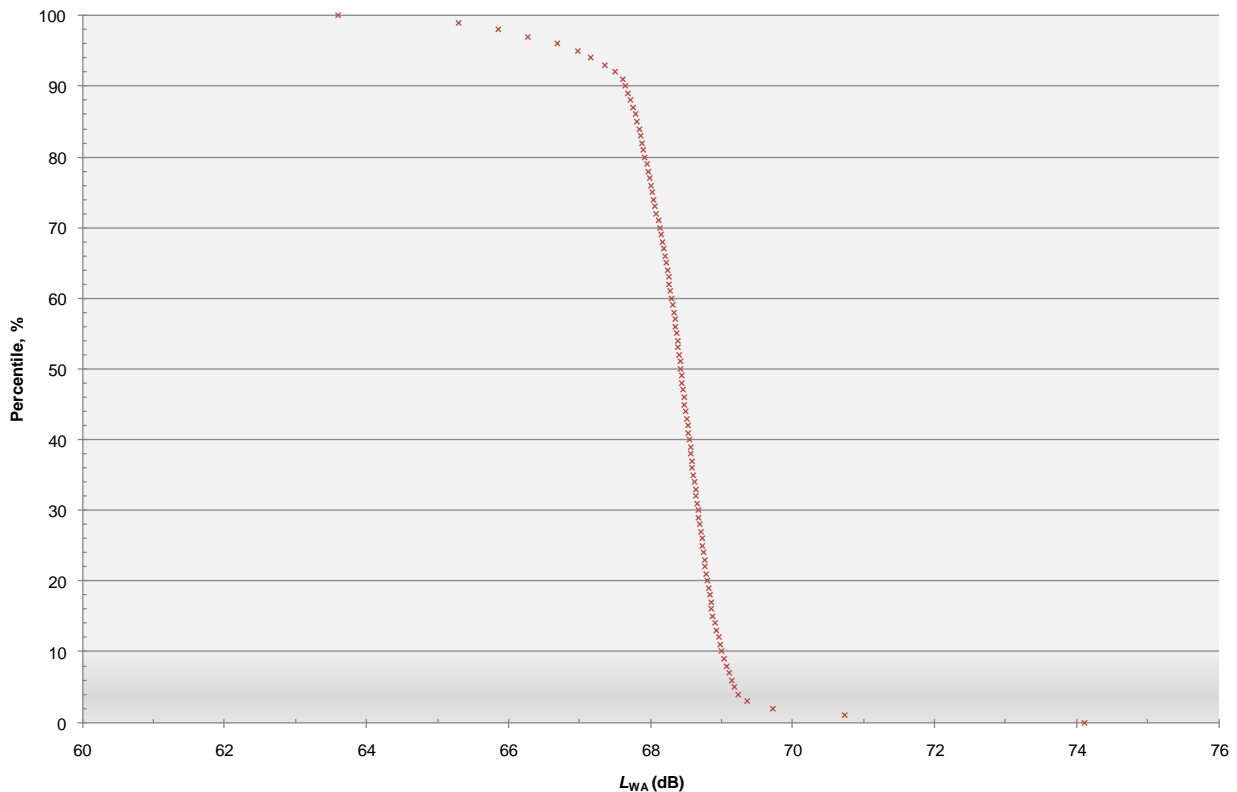

Figure 5-26. 418 Central Buchan, Sound Power Level Statistical Analysis

- 5.3.20. The chart indicates that noise from the ASHP during operation will have a 90% certainty of being within around 1 dB of L_{WA} **68 dB**.
- 5.3.21. Use of Equation 1 leads to an estimation that noise levels from the unit operating normally would drop to L_{Aeq} 42 dB at a distance separation of approximately **11 m**. If a tonal penalty were to be included, then this distance would rise to around **14 m**.

Discussion

- 5.3.22. Whilst the manufacturer has not provided us with detailed information on the fan and compressor speeds, analysis of the ASHP noise data suggests that the fan speed was 790 rpm, and included four fan blades. The fan configuration corresponds with a blade passing frequency of 53 Hz, with second, third and fourth harmonics at 104, 158 and 210 Hz respectively. The compressor was of a scroll type with an unknown speed. Analysis of the defrost cycle frequency

spectrum suggests however that the primary tone is at around 50Hz, which corresponds with a rotational speed of 3000 rpm, typical for this type of compressor. Harmonics of this tone are seen at multiple frequencies in the spectrum, as displayed in the FFT analysis charts for the defrost cycle.

- 5.3.23. During normal operation, the fan contributes a greater amount of noise than the compressor, although tonal content provided by the compressor is audible.

5.4 **422 Fraserburgh (Original ASHP)**

Site description

- 5.4.1. The property is located in a rural area off a quiet road. The ASHP is located to the side of the brick built single story detached property. The unit is seated on concrete paving slab footings.
- 5.4.2. This section details the results for the original ASHP that was subsequently replaced, the results of which will be presented separately.
- 5.4.3. Subjectively the unit appeared to be operating normally with no audible rattle, resonance or fault.

Equipment set up

- 5.4.4. The 9 Channel PULSE system was used at this site.
- 5.4.5. The ASHP was located on reflective ground, and in front of a reflective wall.
- 5.4.6. Accelerometers were fixed to the footings and to the wall surface immediately behind the unit, as shown in Picture 5-10. The accelerometers were fixed to the surfaces using cyanoacrylate cement.



Picture 5-10. 422 Fraserburgh (Original), Footing and Wall-mounted Accelerometers

5.4.7. The microphones were mounted on heavy-duty tripods as shown in Picture 5-11 and Picture 5-12. All microphones were positioned 1 m from the ASHP casing.



Picture 5-11. 422 Fraserburgh, Original ASHP and Microphone Arrangement



Picture 5-12. 422 Fraserburgh, Original ASHP and Microphone Arrangement

Measurement Results

- 5.4.8. The results given by the energy measurements were found to be erroneous for the per-minute logging. The logging data has therefore been used from the alternative per-five-minute logging system.
- 5.4.9. Figure 5-27 presents the $L_{Aeq(1min)}$ measured noise levels at the microphone 1m in front of the unit set against time, along with the per-five-minute logged ASHP power consumption.

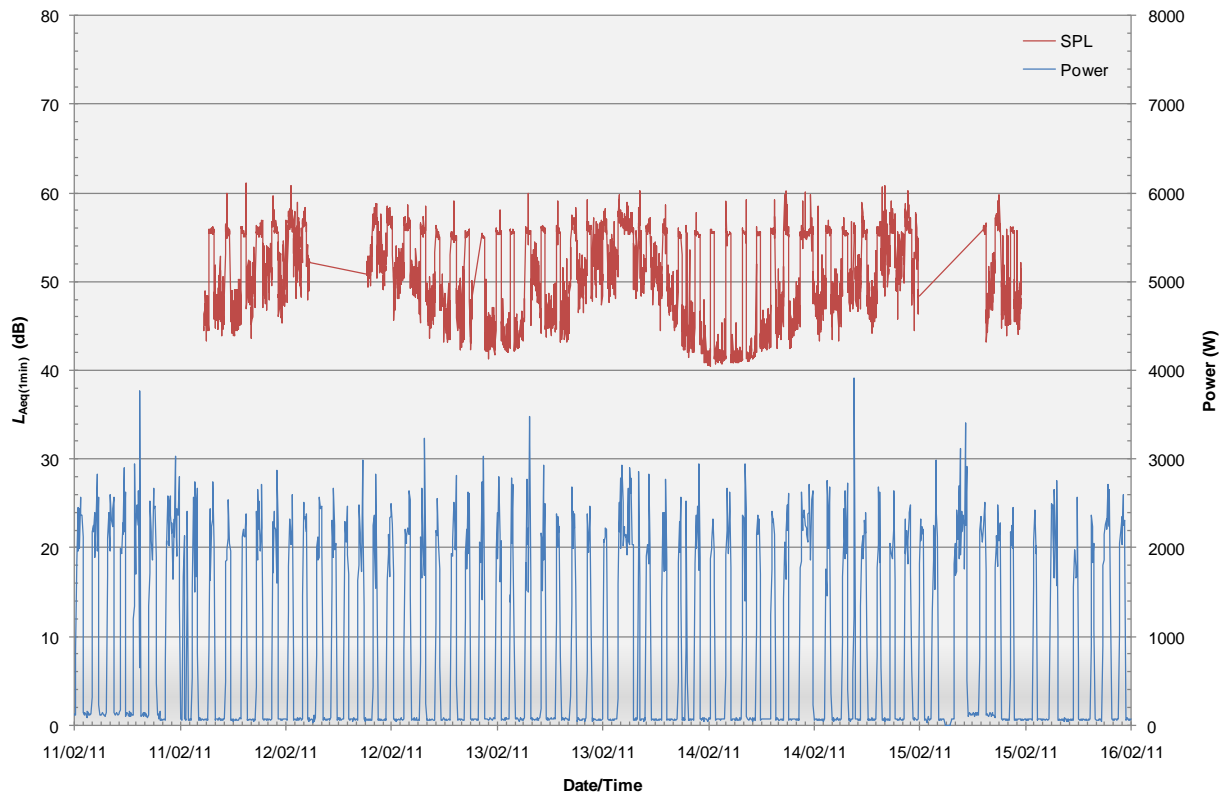

Figure 5-27. 422 Fraserburgh (Original ASHP), Sound Pressure Level and Power Consumption vs Time

- 5.4.10. The PULSE system stopped recording on two occasions and had to be reset.
- 5.4.11. The data highlights that the ASHP is cycling on and off approximately every two hours, consistently throughout the day and night-time periods. Throughout the measurement period, the ASHP was operational for approximately 29% of the time.
- 5.4.12. The trace clearly shows the increase in measured noise level during periods when the ASHP is operating.

Measurement Analysis

- 5.4.13. Figure 5-28 presents a scatter diagram showing the noise levels against the power consumption, for the periods when the ASHP was operating. It is seen that the sound pressure level has no dependence on the power output of the ASHP.

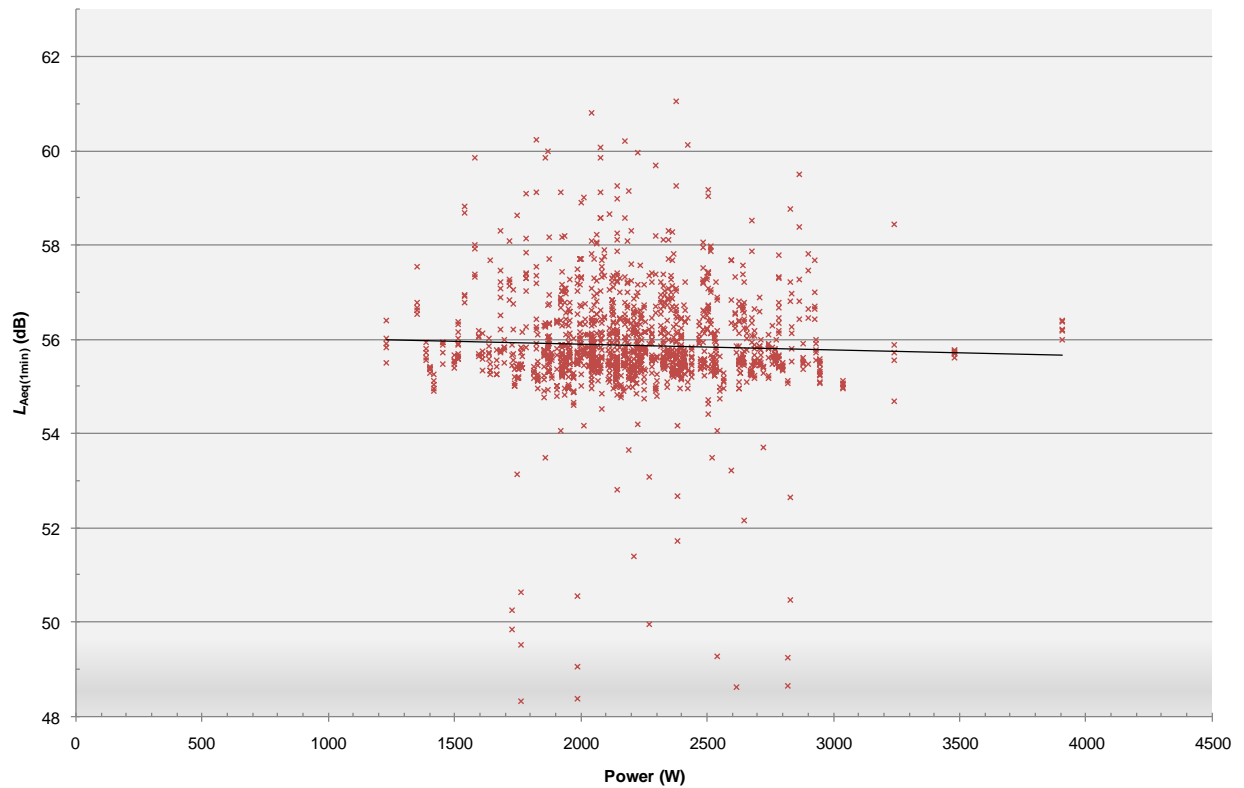

Figure 5-28. 422 Fraserburgh (Original ASHP), Sound Pressure Level vs Power Consumption

5.4.14. Figure 5-29 presents a statistical analysis plot of the percentage of time that a specific noise level would be recorded, when the ASHP is under operation. From this confidence intervals can be presented for the typical noise levels.

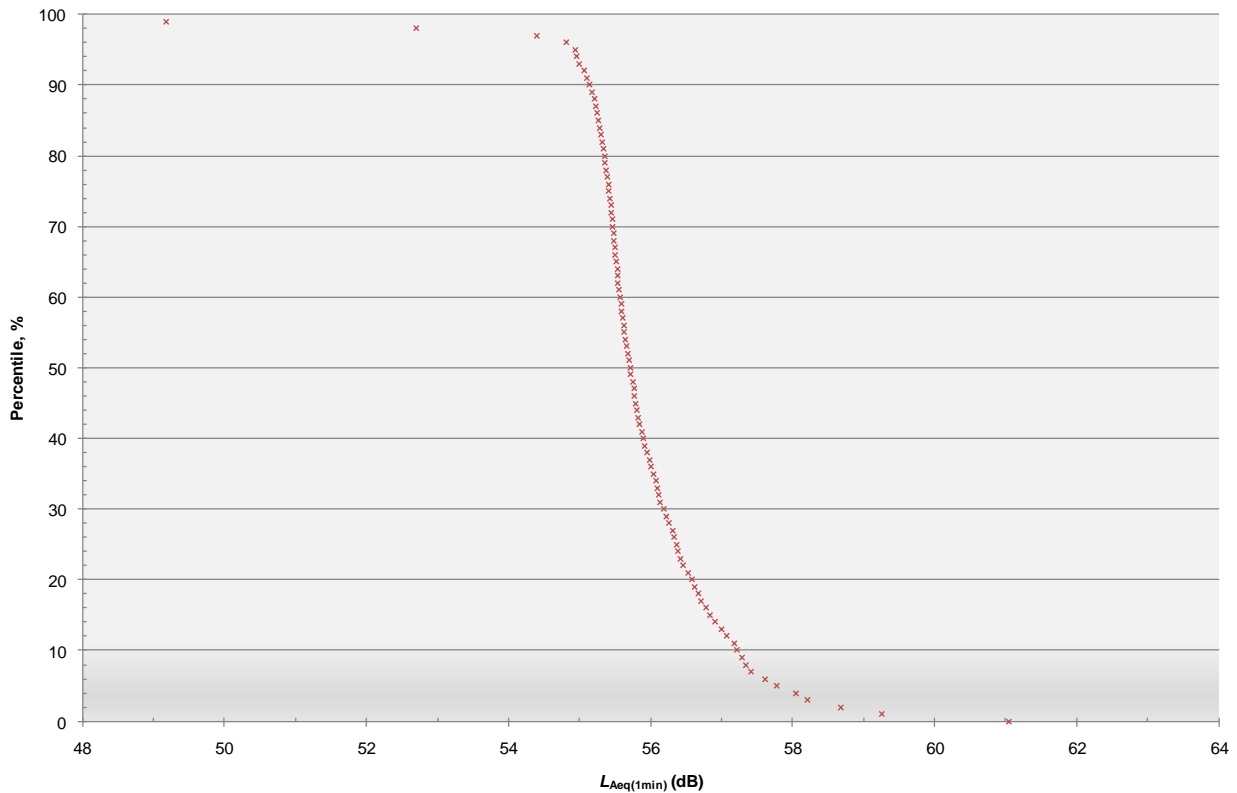

Figure 5-29. 422 Fraserburgh (Original ASHP), Sound Pressure Level Statistical Analysis

5.4.15. The chart indicates that noise from the ASHP during operation will have a 90% certainty of being within around 1.5 dB of $L_{Aeq(1min)}$ **56 dB**. The corresponding total ASHP noise dose over the whole assessment period is calculated as $L_{Aeq(1week)}$ 51 dB.

Defrost Cycle

5.4.16. Analysis of the measurements revealed that defrost cycles are part of the ASHP operation. During these periods, which can last for 3 to 4 minutes, the compressor is operating in reverse, without the fan. The average sound pressure level during a typical defrost cycle is around $L_{Aeq(1min)}$ **54 dB**.

Directivity

5.4.17. Table 5-4 shows the directivity in noise emissions from the unit by comparing the noise levels at the different microphones, for a typical period of ASHP operation.

Table 5-4: Directivity Analysis of the ASHP Noise Emissions $L_{Aeq(1min)}$ dB 422 Fraserburgh (Original ASHP), normal operation				
Microphone Location	Front	Left	Right	Above
Typical Microphone Level	56	54	56	52
Change from front microphone	-	-2	0	-4

5.4.18. It is seen that the ASHP exhibits a slight directivity, such that noise is greater in line with the fan, and on the side nearest the compressor (i.e. the right hand side for this ASHP).

Frequency analysis

5.4.19. For the frequency analysis, a Fast Fourier Transform (FFT) of the signal was performed, averaged over a representative one minute period at a frequency resolution of 2 Hz. The resulting frequency spectrum for the ASHP operating under normal conditions is given in Figure 5-30, with that for the defrost cycle presented in Figure 5-31.

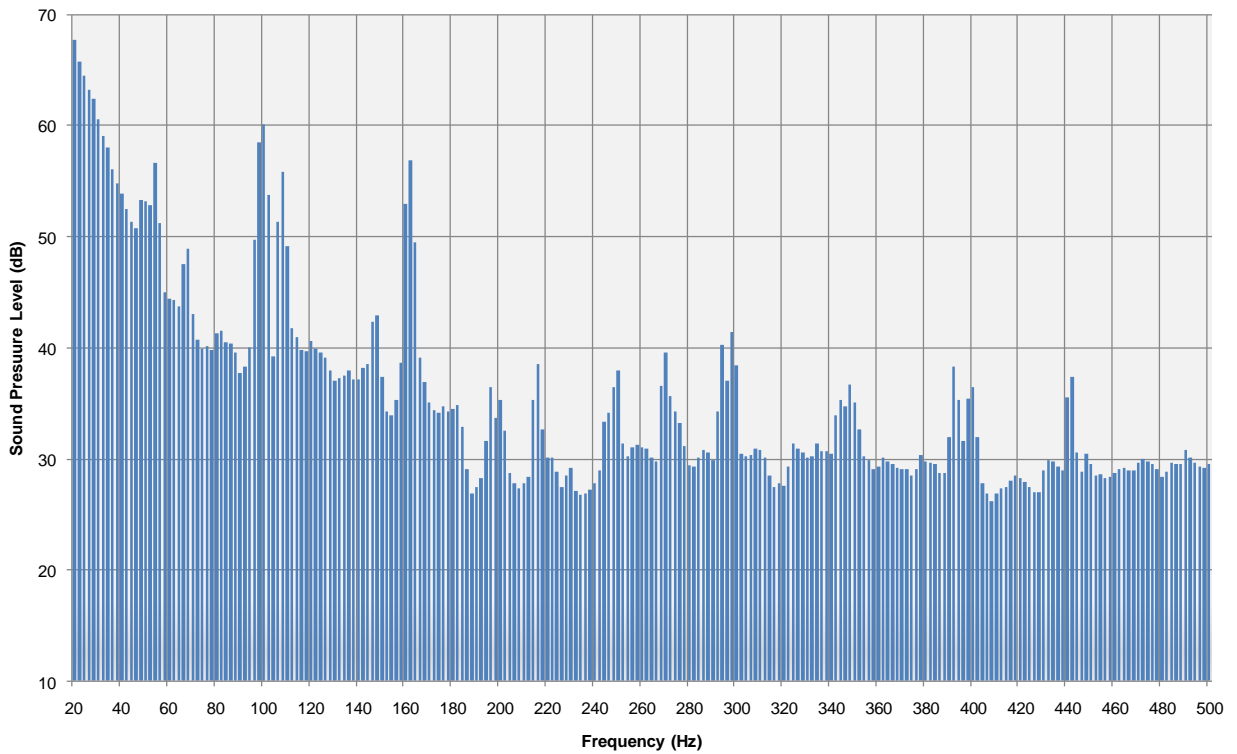

Figure 5-30. 422 Fraserburgh (Original ASHP), Sound Pressure Level Spectrum (Normal Operation)

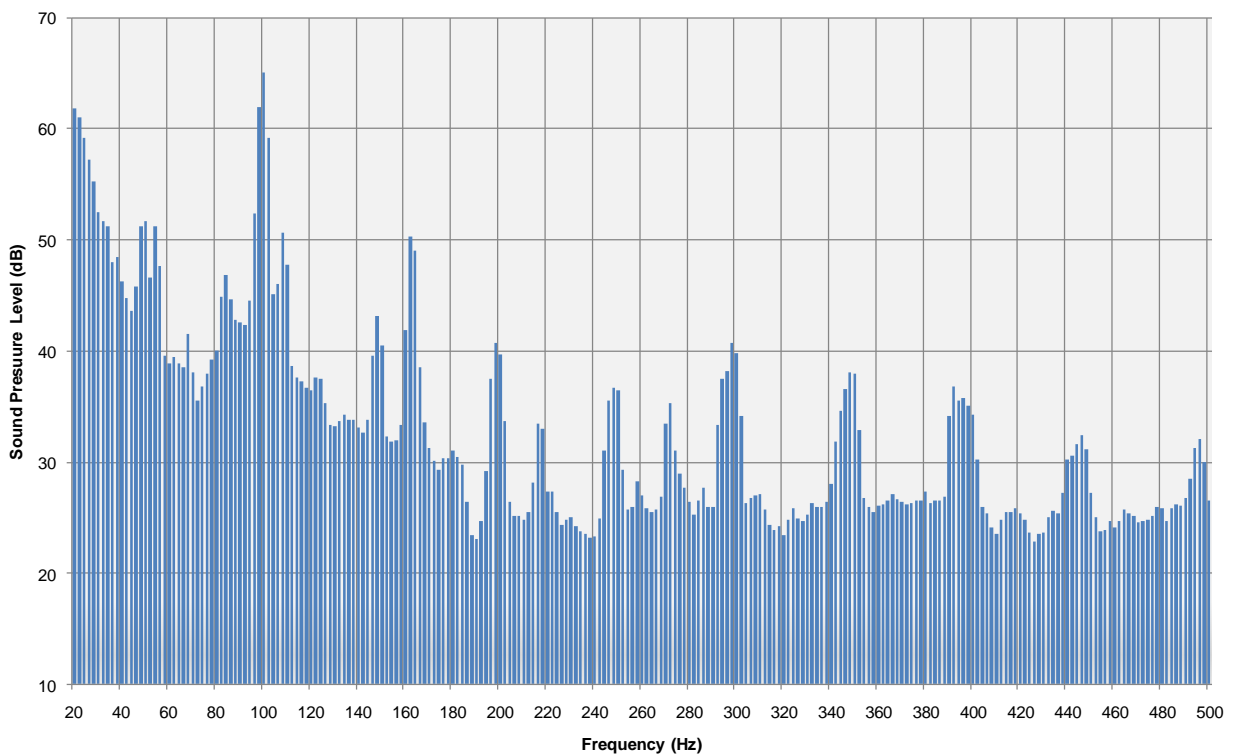
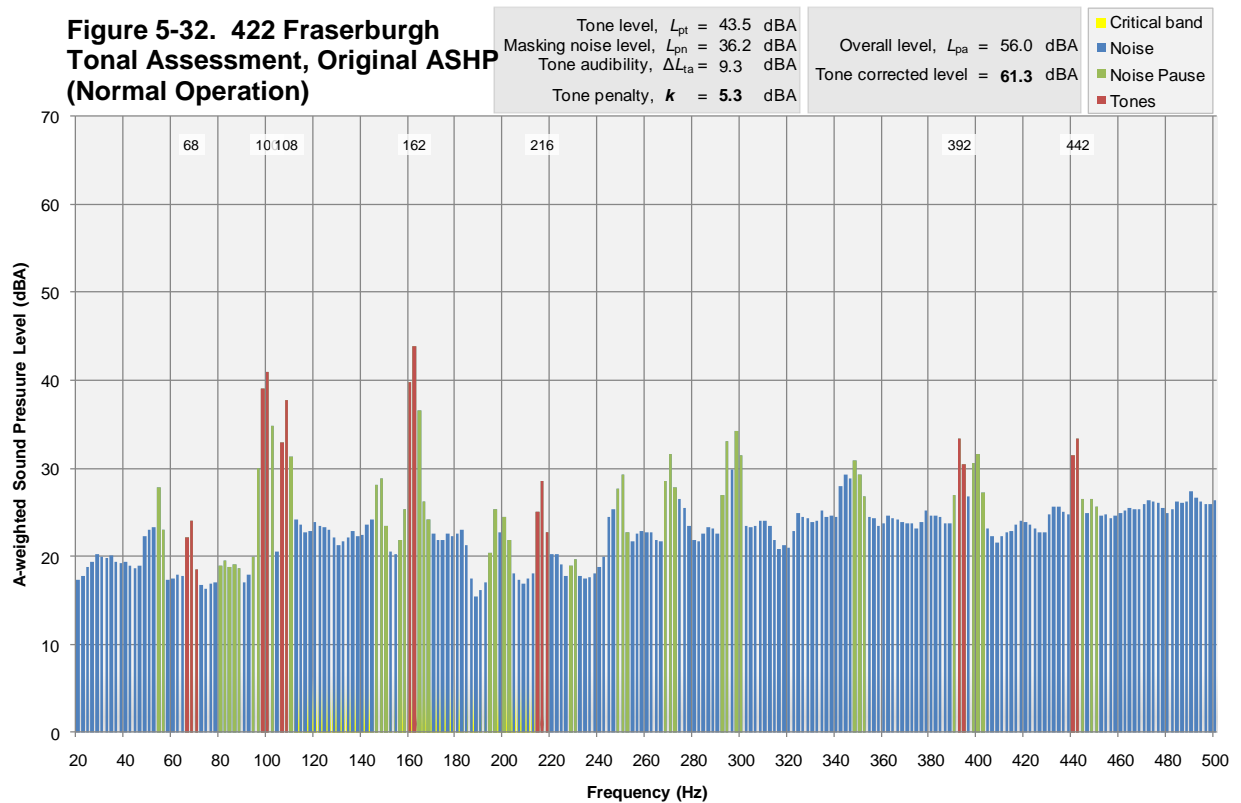
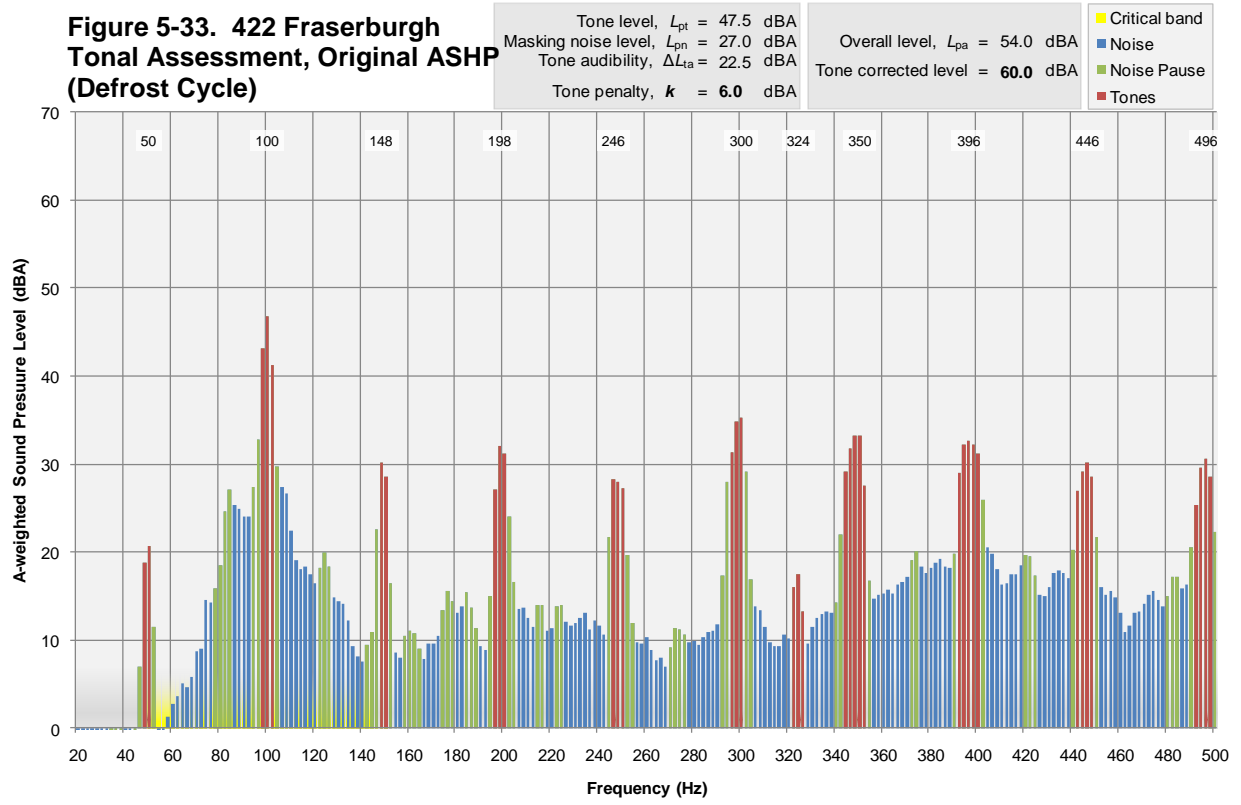

Figure 5-31. 418 Fraserburgh (Original ASHP), Sound Pressure Level Spectrum (Defrost Cycle)

5.4.20. Tonal analysis of the frequency spectra shown in Figure 5-30 and Figure 5-31 has been undertaken in accordance with the Joint Nordic Method (v2). The resulting tonal assessments are presented in Figure 5-32 and Figure 5-33, showing that the tones identified within the spectrum for normal operation would lead to a **5 dB tonal penalty**. During the defrost cycle, the tonal assessment indicates that a **6 dB tonal penalty** would be appropriate.





Sound Power Level calculations

5.4.21. Figure 5-34 presents a statistical analysis plot of the percentage of time that a specific sound power level would be recorded, when the ASHP is under operation.

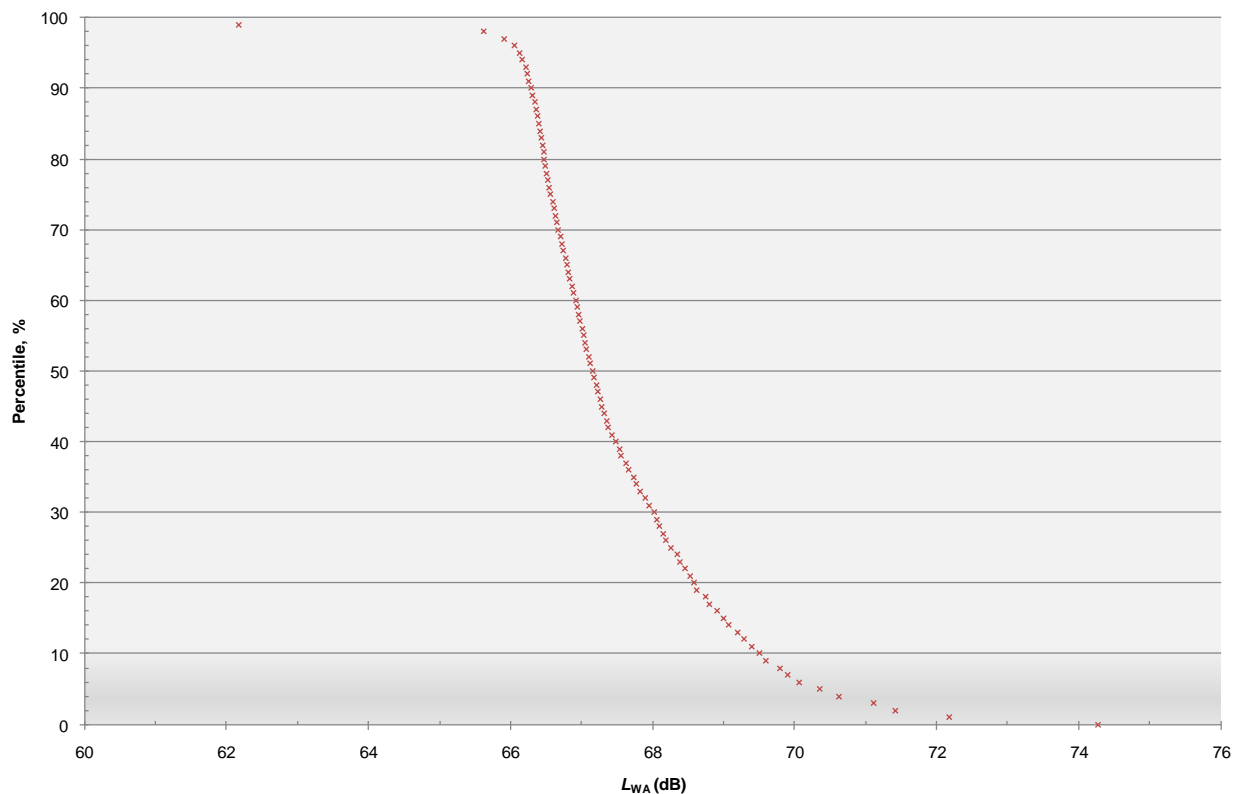

Figure 5-34. 422 Fraserburgh (Original ASHP), Sound Power Level Statistical Analysis

- 5.4.22. The chart indicates that noise from the ASHP during operation will have a 90% certainty of being within around 2 dB of L_{WA} **67 dB**.
- 5.4.23. Use of Equation 1 leads to an estimation that noise levels from the unit operating normally would drop to L_{Aeq} 42 dB at a distance separation of approximately **10 m**. If a tonal penalty were to be included, then this distance would rise to around **18 m**. This assumes that the ASHP is located in the common mounting scenario as detailed in Section 3.41, which is not necessarily representative of the actual measured condition.

Vibration

- 5.4.24. An FFT analysis of the vibration levels recorded for normal operation of the ASHP is shown in Figure 5-35. The overall weighted peak vibration level at the wall surface was 0.0035 ms^{-2} , significantly below the average perception threshold for whole-body vibration.

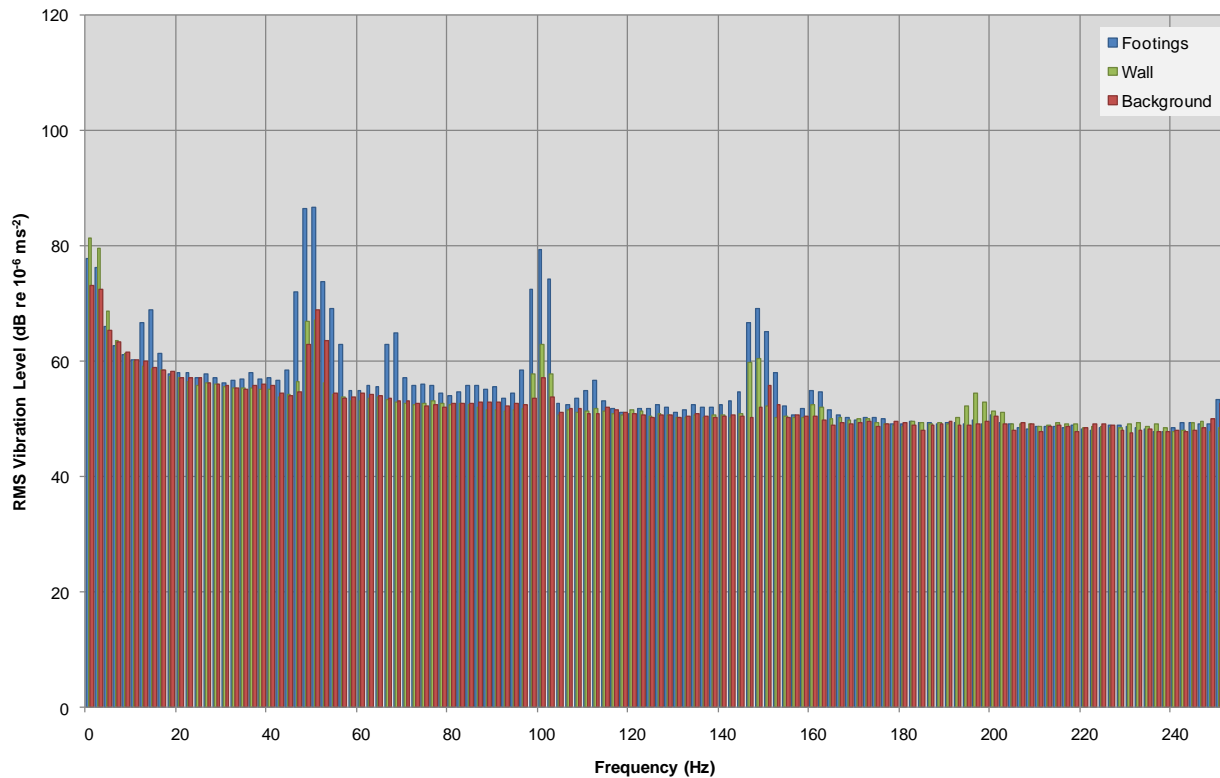

Figure 5-35. 422 Fraserburgh (Original ASHP), Vibration Levels

Discussion

5.4.25. Whilst the manufacturer has not provided us with detailed information on the fan and compressor speeds, inspection of the results and experience of similar units suggest that the fan speed was around 810 rpm, and included four fan blades. This fan configuration corresponds with a blade passing frequency of 54 Hz, with second and third harmonics at 108 and 162 Hz respectively. These effects are seen prominently in the frequency spectrum for normal operation. The compressor was of a scroll type with an unknown speed. Analysis of the defrost cycle frequency spectrum suggests however that the primary tone is at around 50Hz, which corresponds with a rotational speed of 3000 rpm, typical for this type of compressor. Harmonics of this tone are seen at multiple frequencies in the spectrum.

- 5.4.26. During normal operation, the fan contributes a greater amount of noise than the compressor, although the tonal content provided by compressor is audible.
- 5.4.27. The vibration data shows that the compressor contributes greatest to the vibration emissions, with a small amount of vibration caused by the fan.

5.5 **422 Fraserburgh, Aberdeenshire (Replacement ASHP)**

Site description

- 5.5.1. The site is identical to that detailed above.
- 5.5.2. This section details the results for the replacement ASHP.
- 5.5.3. Subjectively the unit appeared to be operating normally with no audible rattle, resonance or fault.

Equipment set up

- 5.5.4. The 5 Channel PULSE system was used at this site.
- 5.5.5. The ASHP was located on reflective ground, and in front of a reflective wall.
- 5.5.6. An accelerometer was fixed to the casing of the ASHP, as shown in Picture 5-13. The accelerometer was fixed to the surface using cyanoacrylate cement.



Picture 5-13. 422 Fraserburgh (Replacement), Casing-mounted Accelerometer

- 5.5.7. The microphones were mounted on heavy-duty tripods as shown in Picture 5-14. All microphones were positioned 1 m from the ASHP casing.



Picture 5-14. 422 Fraserburgh, Replacement ASHP and Microphone Arrangement

Measurement Results

- 5.5.8. Figure 5-36 presents the $L_{Aeq(1min)}$ measured noise levels at the microphone 1m in front of the unit set against time, along with the ASHP power consumption.

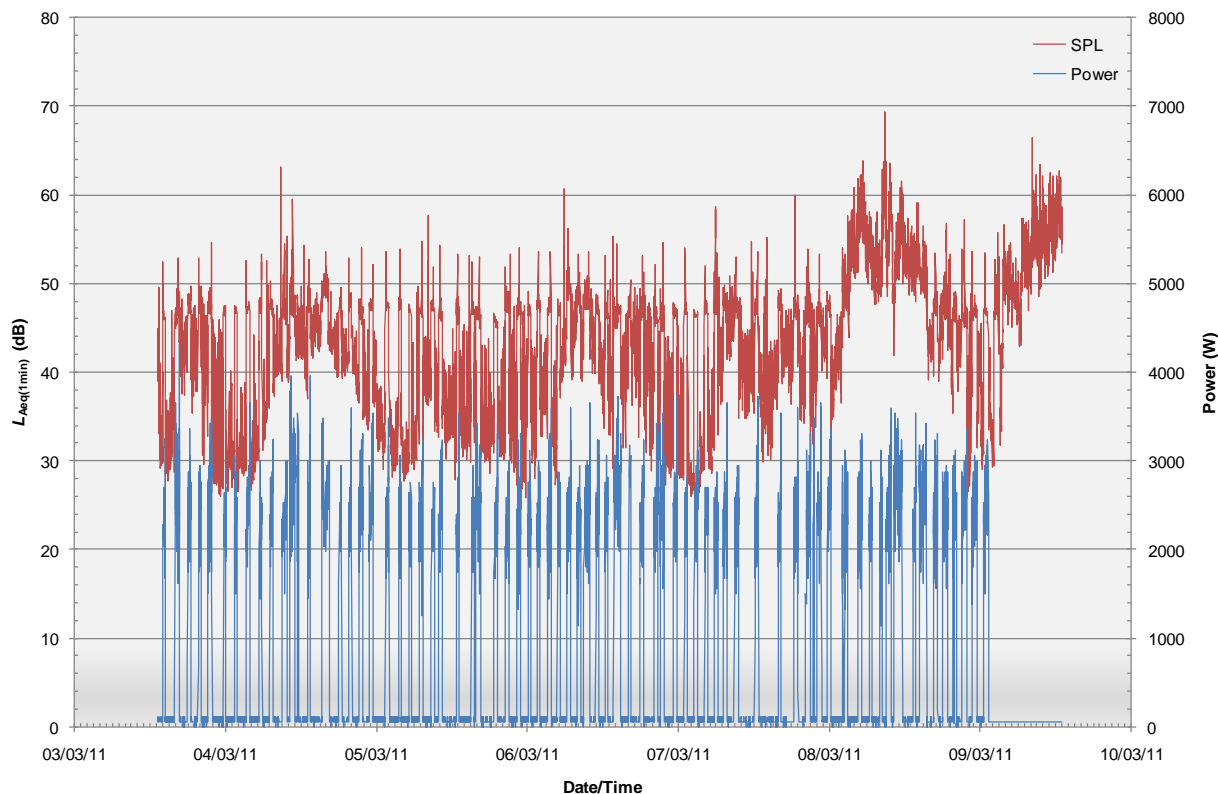

Figure 5-36. 422 Fraserburgh (Replacement), SPL and Power Consumption vs Time

- 5.5.9. The data highlights that the ASHP is cycling on and off approximately every two and a half hours, consistently throughout the day and night-time periods. Throughout the measurement period, the ASHP was operational for approximately 30% of the time.
- 5.5.10. The trace clearly shows the increase in measured noise level during periods when the ASHP is operating.
- 5.5.11. Due to high winds on the 8th and 9th March, these periods have been excluded from the analysis.

Measurement Analysis

- 5.5.12. Figure 5-37 presents a scatter diagram showing the noise levels against the power consumption, for the periods when the ASHP was operating. It is seen that the sound pressure level has no dependence on the power output of the ASHP.

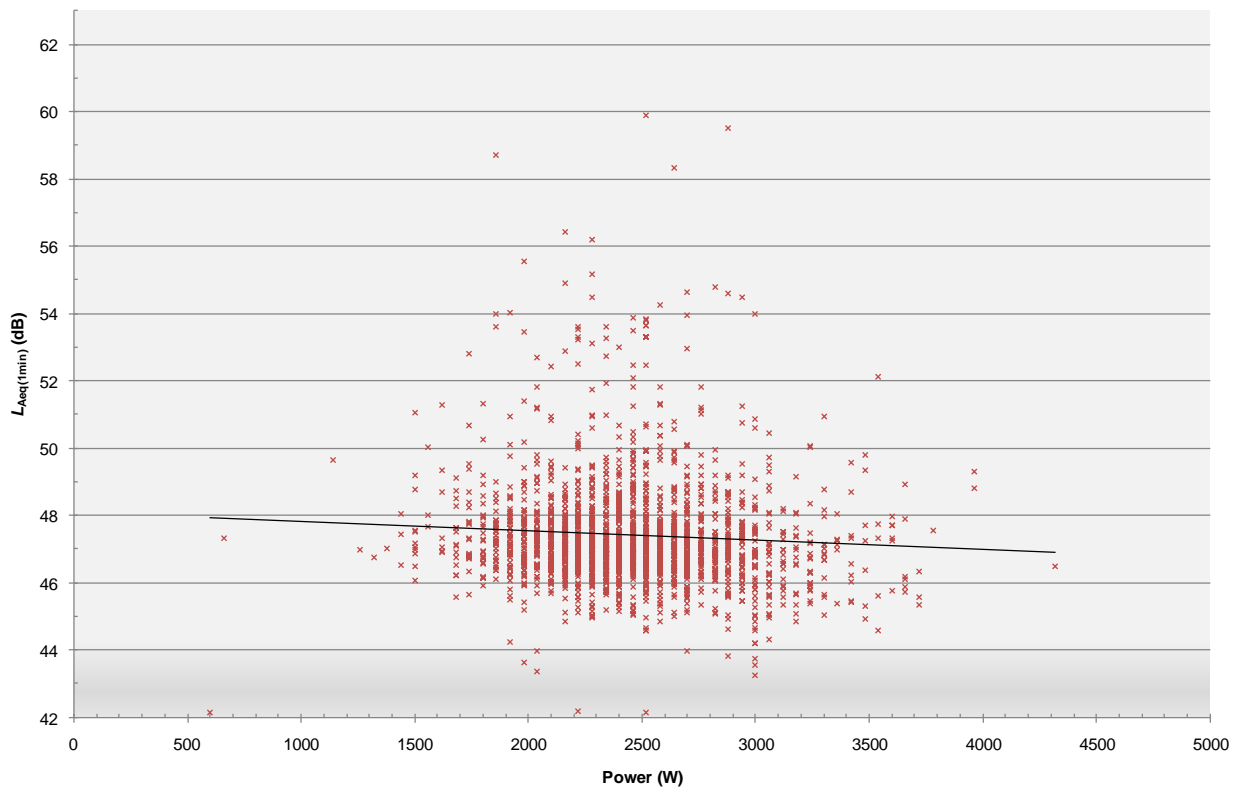

Figure 5-37. 422 Fraserburgh (Replacement), SPL vs Power Consumption

5.5.13. Figure 5-38 presents a statistical analysis plot of the percentage of time that a specific noise level would be recorded, when the ASHP is under operation. From this confidence intervals can be presented for the typical noise levels.

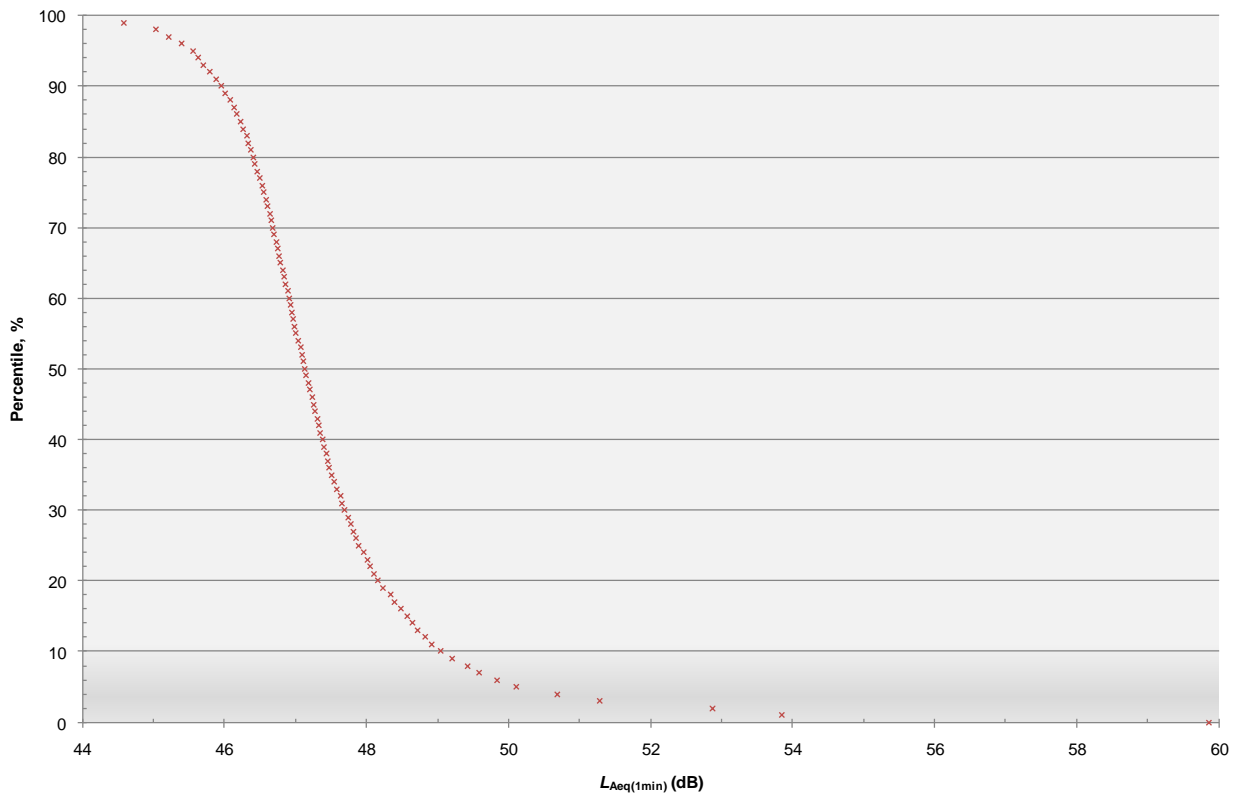

Figure 5-38. 422 Fraserburgh (Replacement), Sound Pressure Level Statistical Analysis

5.5.14. The chart indicates that noise from the ASHP during operation will have a 90% certainty of being within around 2 dB of $L_{Aeq(1min)}$ **47 dB**. The corresponding total ASHP noise dose over the whole assessment period is calculated as $L_{Aeq(1week)}$ **42 dB**.

Defrost Cycle

5.5.15. Analysis of the measurements revealed that defrost cycles are part of the ASHP operation. During these periods, which can last for 1 to 2 minutes, the compressor is operating in reverse, without the fan. The average sound pressure level during a typical defrost cycle is around $L_{Aeq(1min)}$ **50 dB**.

Directivity

- 5.5.16. Table 5-5 shows the directivity in noise emissions from the unit by comparing the noise levels at the different microphones, for a typical period of ASHP operation.

Table 5-5: Directivity Analysis of the ASHP Noise Emissions $L_{Aeq(1min)}$ dB 422 Fraserburgh (Replacement), normal operation				
Microphone Location	Front	Left	Right	Above
Typical Microphone Level	47	44	45	45
Change from front microphone	-	-3	-2	-2

- 5.5.17. It is seen that the ASHP exhibits a slight directivity, such that noise is greater in line with the fan.

Frequency analysis

- 5.5.18. For the frequency analysis, a Fast Fourier Transform (FFT) of the signal was performed, averaged over a representative one minute period at a frequency resolution of 2 Hz. The resulting frequency spectrum for the ASHP operating under normal conditions is given in Figure 5-39, with that for the defrost cycle presented in Figure 5-40.

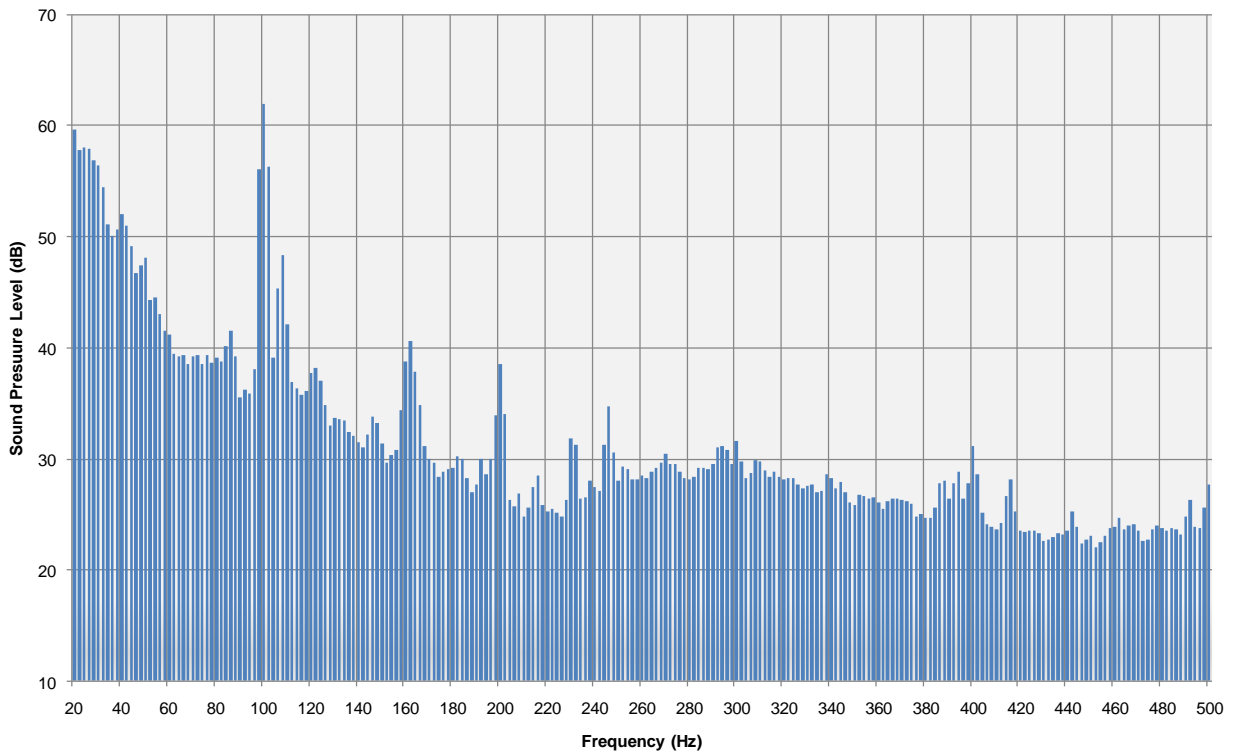

Figure 5-39. 422 Fraserburgh (Replacement), SPL Spectrum (Normal Operation)

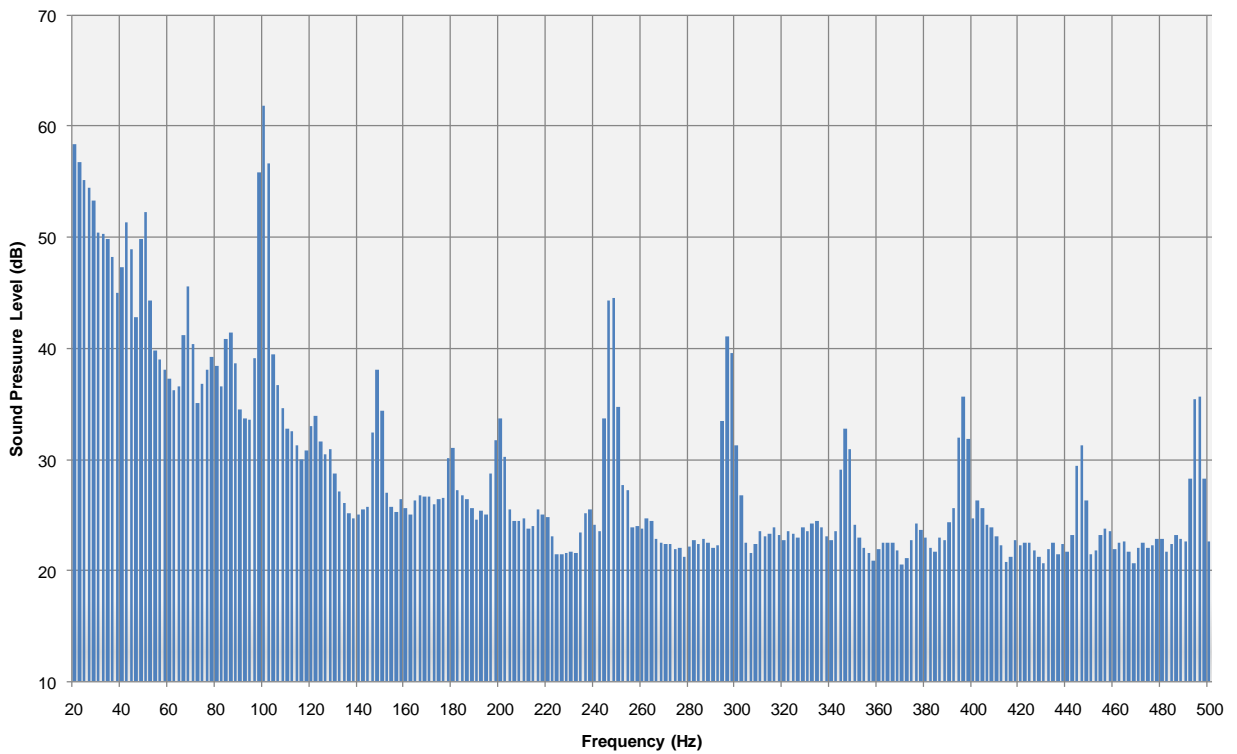
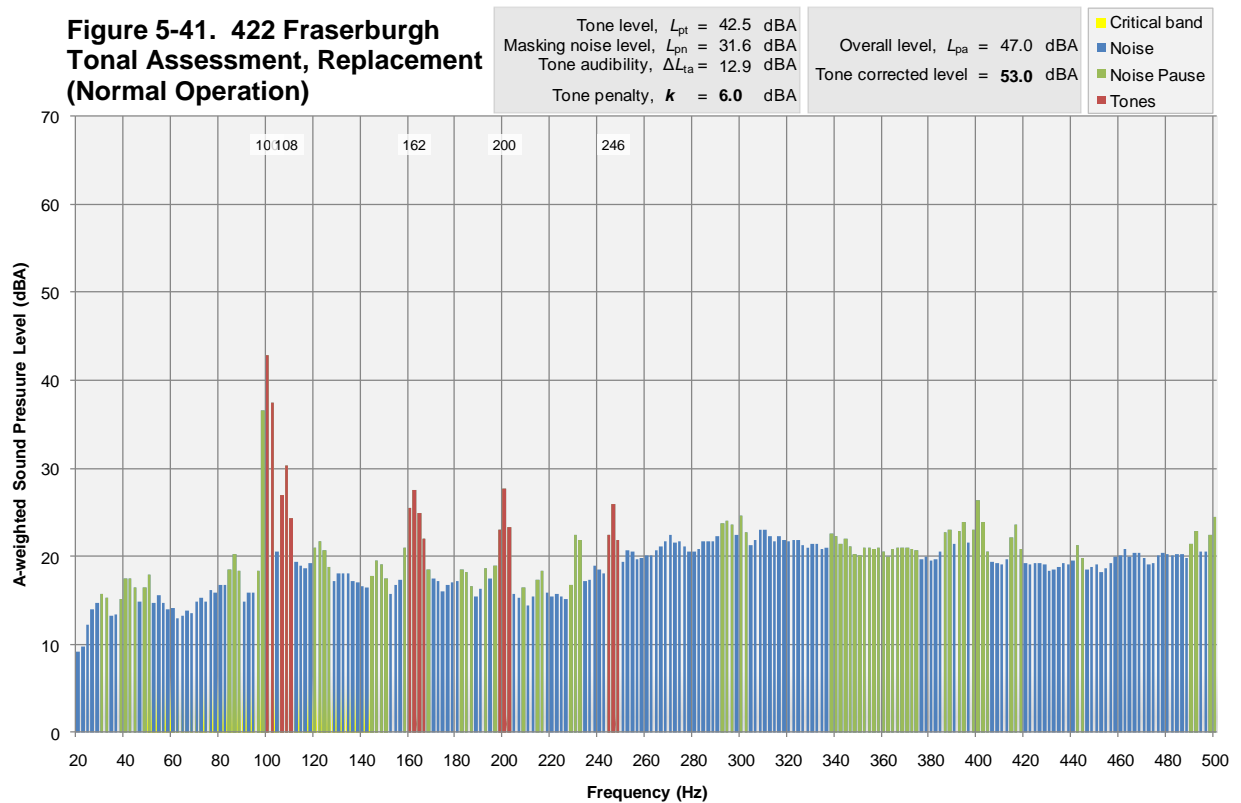
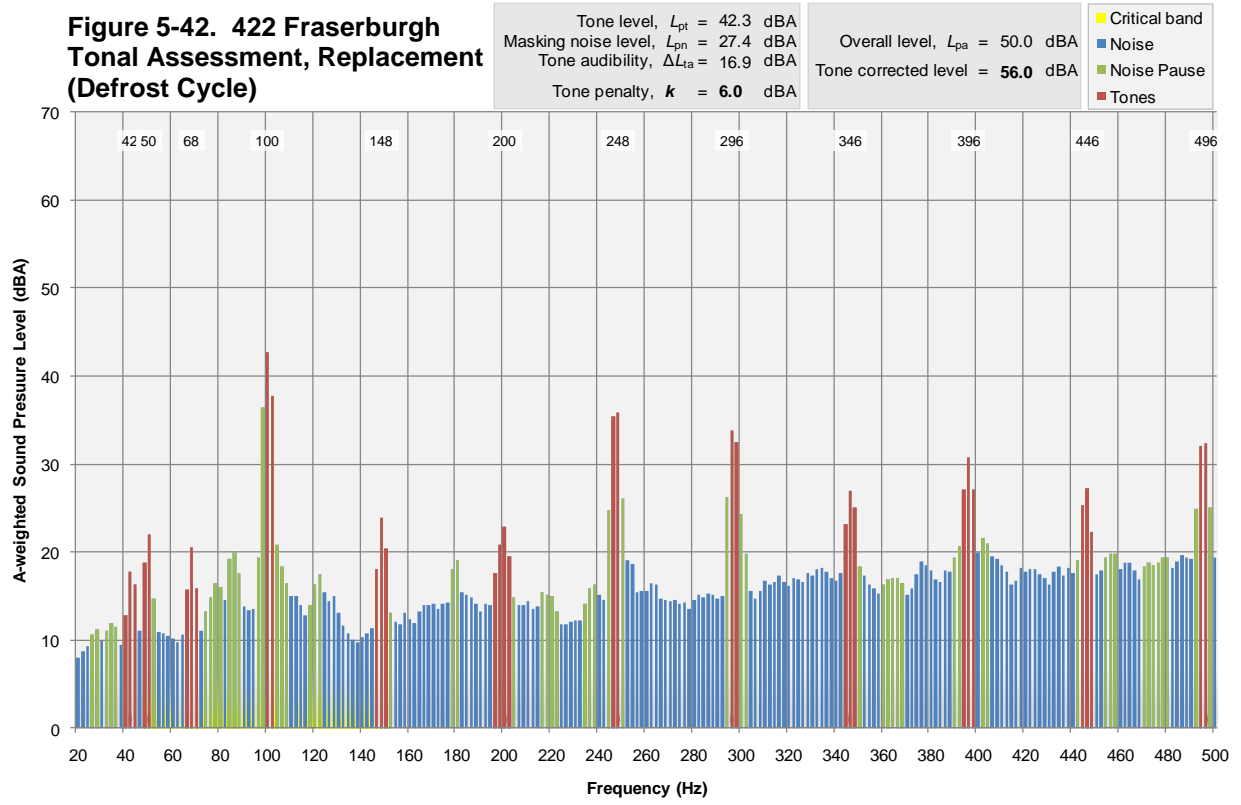

Figure 5-40. 418 Fraserburgh (Replacement), SPL Spectrum (Defrost Cycle)

5.5.19. Tonal analysis of the frequency spectra shown in Figure 5-39 and Figure 5-40 has been undertaken in accordance with the Joint Nordic Method (v2). The resulting tonal assessments are presented in Figure 5-41 and Figure 5-42, showing that the tones identified within the spectrum for normal operation would lead to a **6 dB tonal penalty**. During the defrost cycle, the tonal assessment indicates that a **6 dB tonal penalty** would also be appropriate.





Sound Power Level calculations

5.5.20. Figure 5-43 presents a statistical analysis plot of the percentage of time that a specific sound power level would be recorded, when the ASHP is under operation.

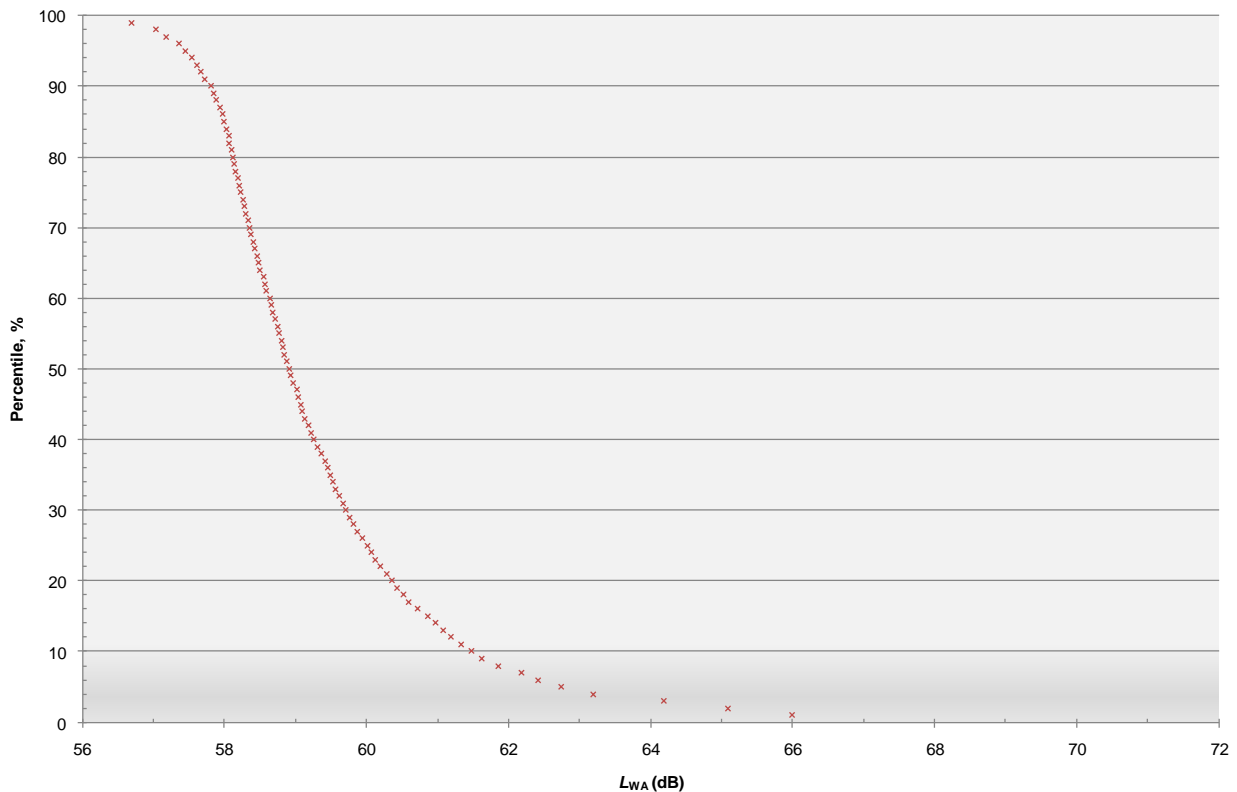

Figure 5-43. 422 Fraserburgh (Replacement), Sound Power Level Statistical Analysis

- 5.5.21. The chart indicates that noise from the ASHP during operation will have a 90% certainty of being within around 2 dB of L_{WA} **59 dB**.
- 5.5.22. Use of Equation 1 leads to an estimation that noise levels from the unit operating normally would drop to L_{Aeq} 42 dB at a distance separation of approximately **4 m**. If a tonal penalty were to be included, then this distance would rise to around **8 m**. This assumes that the ASHP is located in the common mounting scenario as detailed in Section 3.41, which is not necessarily representative of the actual measured condition.

Vibration

- 5.5.23. An FFT analysis of the vibration levels recorded for normal operation of the ASHP is shown in Figure 5-44. The peaks in the background spectrum at 100 and 200 Hz are deemed to be due to an electrical component within the ASHP.

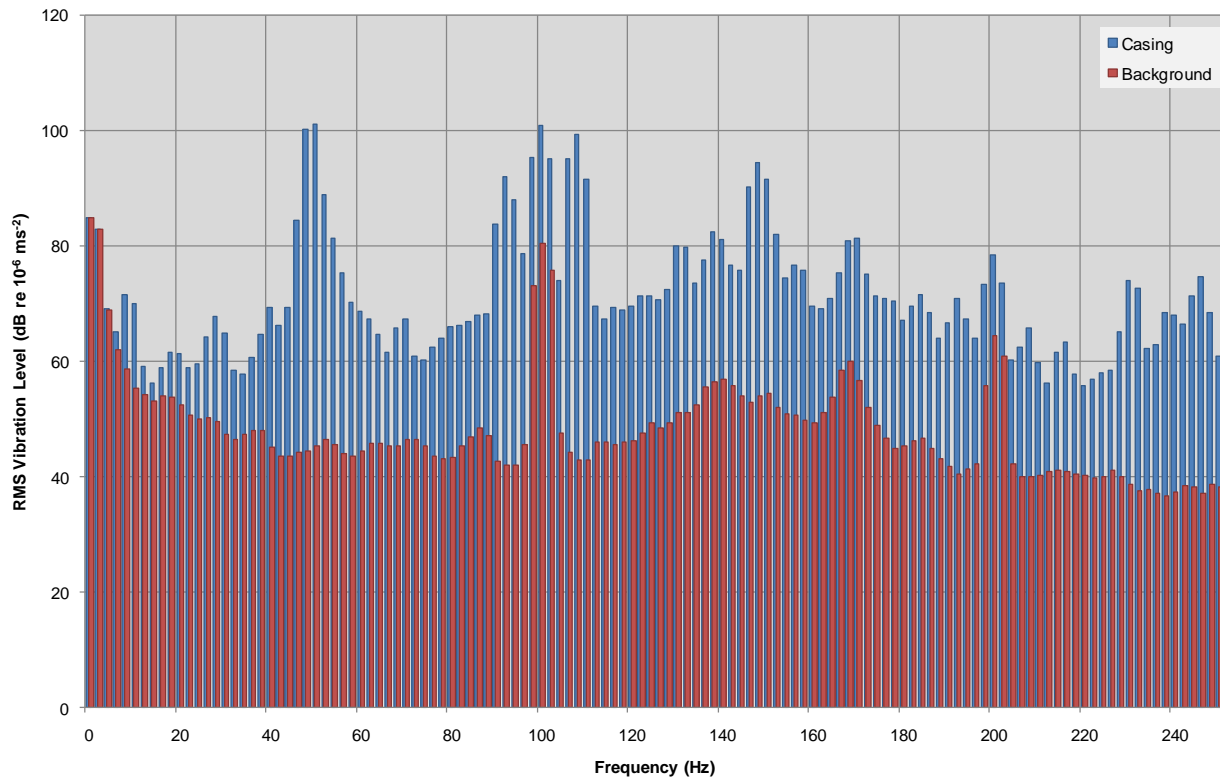

Figure 5-44. 422 Fraserburgh (Replacement), Vibration Levels

Discussion

5.5.24. Whilst the manufacturer has not provided us with detailed information on the fan and compressor speeds, inspection of the results and experience of similar units suggest that the fan speed was around 810 rpm, and included four fan blades. This fan configuration corresponds with a blade passing frequency of 54 Hz, with second and third harmonics at 108 and 162 Hz respectively. These effects are seen in the frequency spectrum for normal operation. The compressor was of a scroll type with an unknown speed. Analysis of the defrost cycle frequency spectrum suggests however that the primary tone is at around 50Hz, which corresponds with a rotational speed of 3000 rpm, typical for this type of compressor. Harmonics of this tone are seen at multiple frequencies in the spectrum.

- 5.5.25. During normal operation, the compressor contributes a greater amount of noise than the fan, and also provides the majority of the tonal content.
- 5.5.26. This replacement 6.0 kW ASHP measured 9 dB quieter than the initial 8.0 kW ASHP. The manufacturer's data suggested a reduction in noise by 7 dB would have been achievable.
- 5.5.27. The vibration data shows that both the compressor and fan contribute to the vibration emissions.

5.6 **443 Cheshire West**

Site description

- 5.6.1. The property is located in a small village off a quiet road. The ASHP is located to the rear of the brick built single story semi-detached property. The unit is mounted onto the wall surface, supported from a metal frame fixed to the brickwork. Vibration isolation couplings were used between the unit and the framework.
- 5.6.2. Subjectively the unit appeared to be operating normally with no audible rattle, resonance or fault.

Equipment set up

- 5.6.3. The 9 Channel PULSE system was used at this site.
- 5.6.4. The unit was mounted above a mixed ground surface of soil and paving slabs.
- 5.6.5. Accelerometers were fixed to the unit casing and to the wall surface immediately behind the unit. The accelerometers were fixed to the surfaces using cyanoacrylate cement.
- 5.6.6. The microphones were mounted on a temporary scaffolding framework as shown in Picture 5-15 and Picture 5-16. All microphones were positioned 1 m from the ASHP casing.



Picture 5-15. 443 Cheshire West, ASHP and Microphone Arrangement



Picture 5-16. 443 Cheshire West, ASHP and Microphone Arrangement

Measurement Results

5.6.7. Figure 5-45 presents the $L_{Aeq(1min)}$ measured noise levels at the microphone 1m in front of the unit set against time, along with the per-minute logged ASHP power consumption.

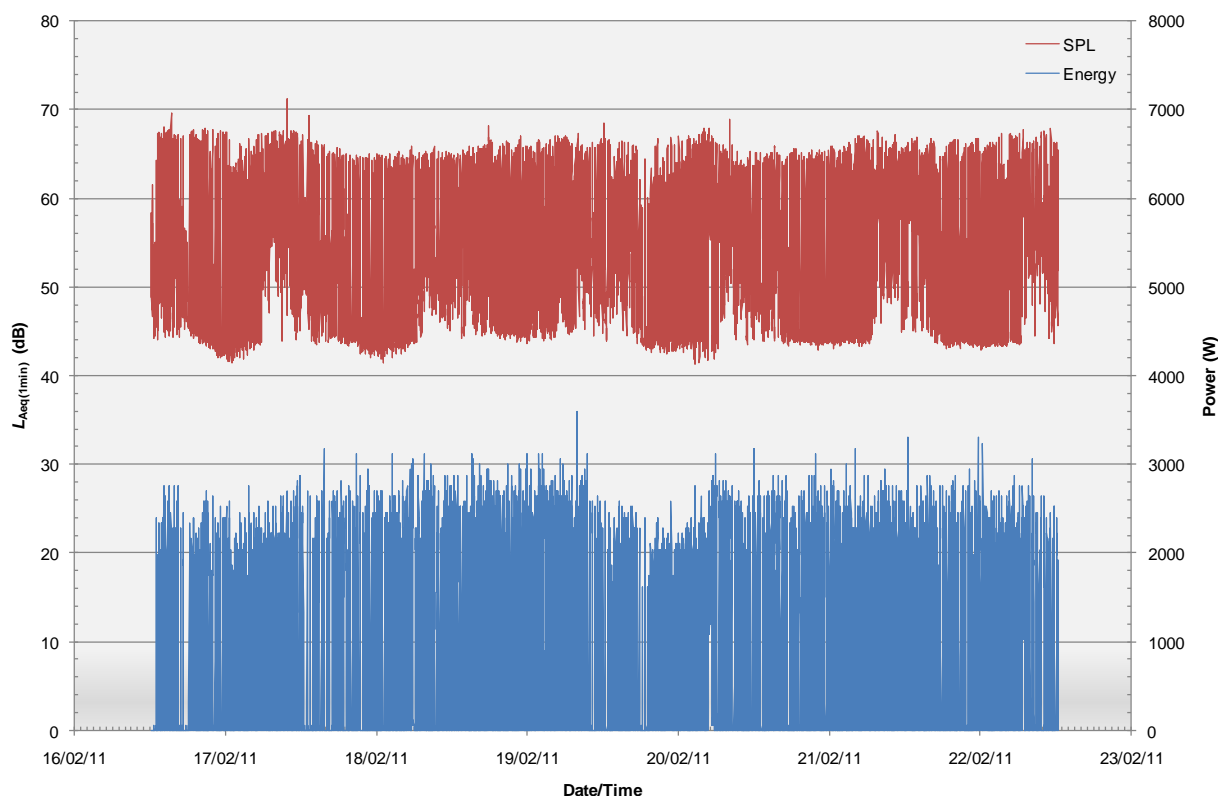

Figure 5-45. 443 Cheshire West, Sound Pressure Level and Power Consumption vs Time

5.6.8. The chart highlights that the ASHP is cycling on and off very frequently, approximately every twenty minutes, throughout the day and night time periods. When the unit is operational, it is on for approximately four minutes. Throughout the measurement period, the ASHP was operational for approximately 22% of the time.

5.6.9. The data shows an increase in measured noise level during periods when the ASHP is operating.

Measurement Analysis

5.6.10. Figure 5-2 presents a scatter diagram showing the noise levels against the power consumption, for the periods when the ASHP was operating. The chart trend line indicates a slight increase in noise level with ASHP power level, although the fit is not conclusive, with a regression coefficient (r^2) of 23%.

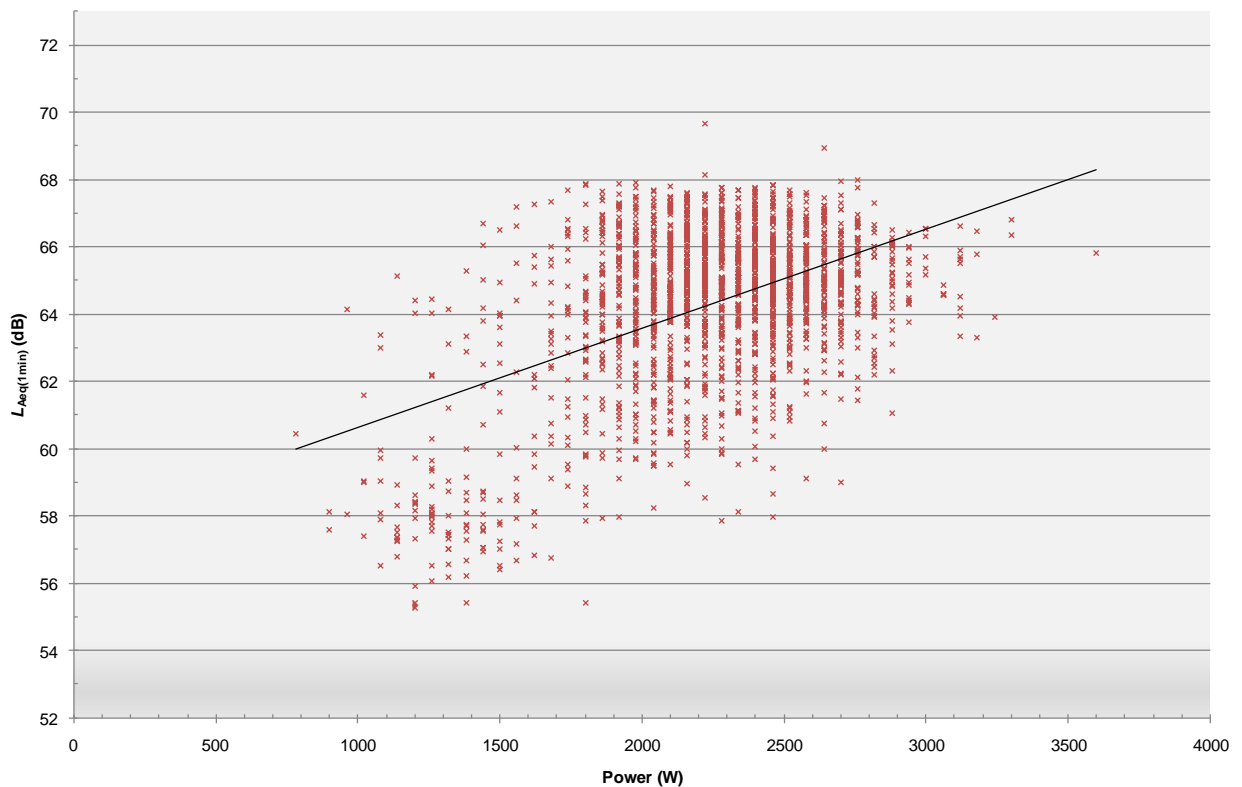

Figure 5-46. 443 Cheshire West, Sound Pressure Level vs Power Consumption

5.6.11. Figure 5-47 presents a statistical analysis plot of the percentage of time that a specific noise level would be recorded, when the ASHP is under operation. From this confidence intervals can be presented for the typical noise levels.

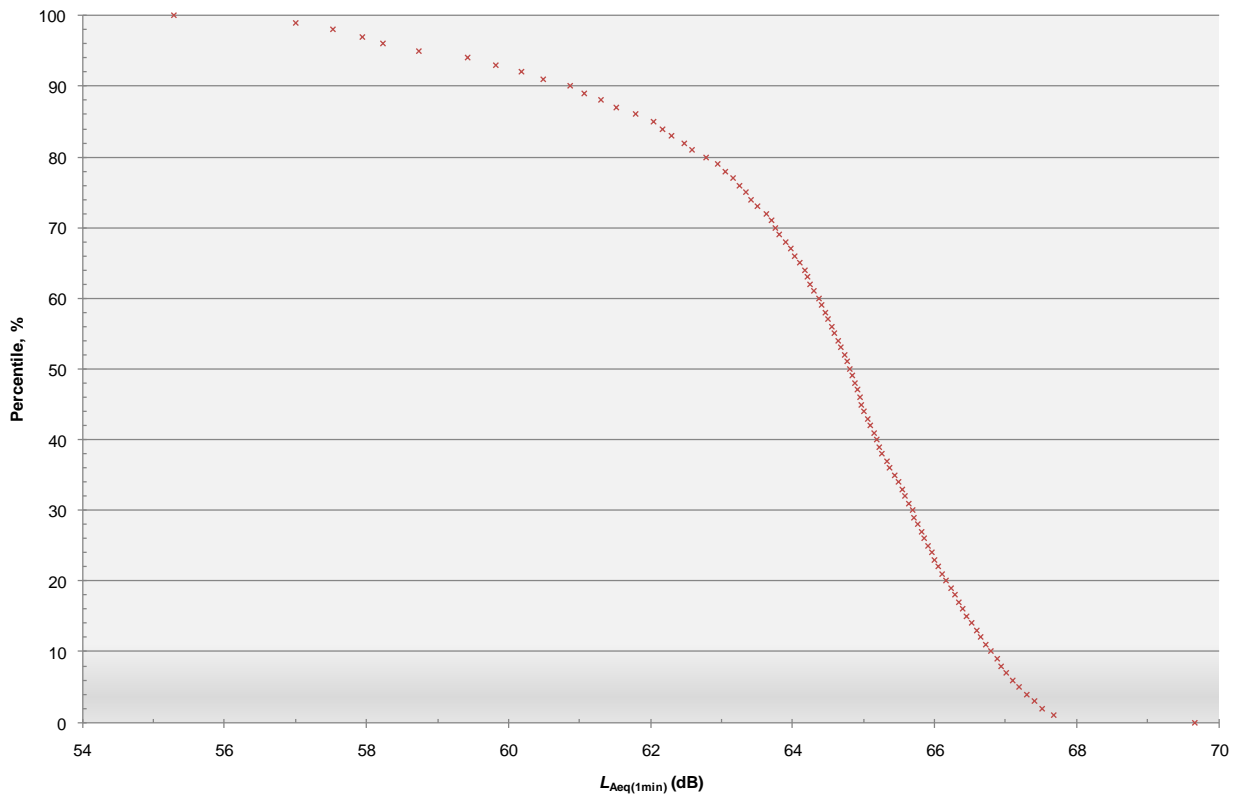

Figure 5-47. 443 Cheshire West, Sound Pressure Level Statistical Analysis

5.6.12. The chart indicates that noise from the ASHP during operation will have a 90% certainty of being within around 4 dB of $L_{Aeq(1min)}$ **64 dB**. The corresponding total ASHP noise dose over the whole assessment period is calculated as $L_{Aeq(1week)}$ **58 dB**.

Defrost Cycle

5.6.13. Analysis of the measurements revealed that defrost cycles are part of the ASHP operation. During these periods, which can last for 2 to 3 minutes, the compressor is operating in reverse, without the fan. The average sound pressure level during a typical defrost cycle is around $L_{Aeq(1min)}$ **57 dB**.

Directivity

5.6.14. Table 5-6 shows the directivity in noise emissions from the unit by comparing the noise levels at the different microphones, for a typical period of ASHP operation.

Table 5-6: Directivity Analysis of the ASHP Noise Emissions $L_{Aeq(1min)}$ dB 443 Cheshire West, normal operation				
Microphone Location	Front	Left	Right	Above
Typical Microphone Level	64	63	62	59
Change from front microphone	-	-1	-2	-5

5.6.15. It is seen that the ASHP exhibits a slight directivity, such that noise is greatest in line with the fan, whilst there is a reduction in noise above the ASHP.

Frequency analysis

5.6.16. For the frequency analysis, a Fast Fourier Transform (FFT) of the signal was performed, averaged over a representative one minute period at a frequency resolution of 2 Hz. The resulting frequency spectrum for the ASHP operating under normal conditions is given in Figure 5-48, with that for the defrost cycle given in Figure 5-49.

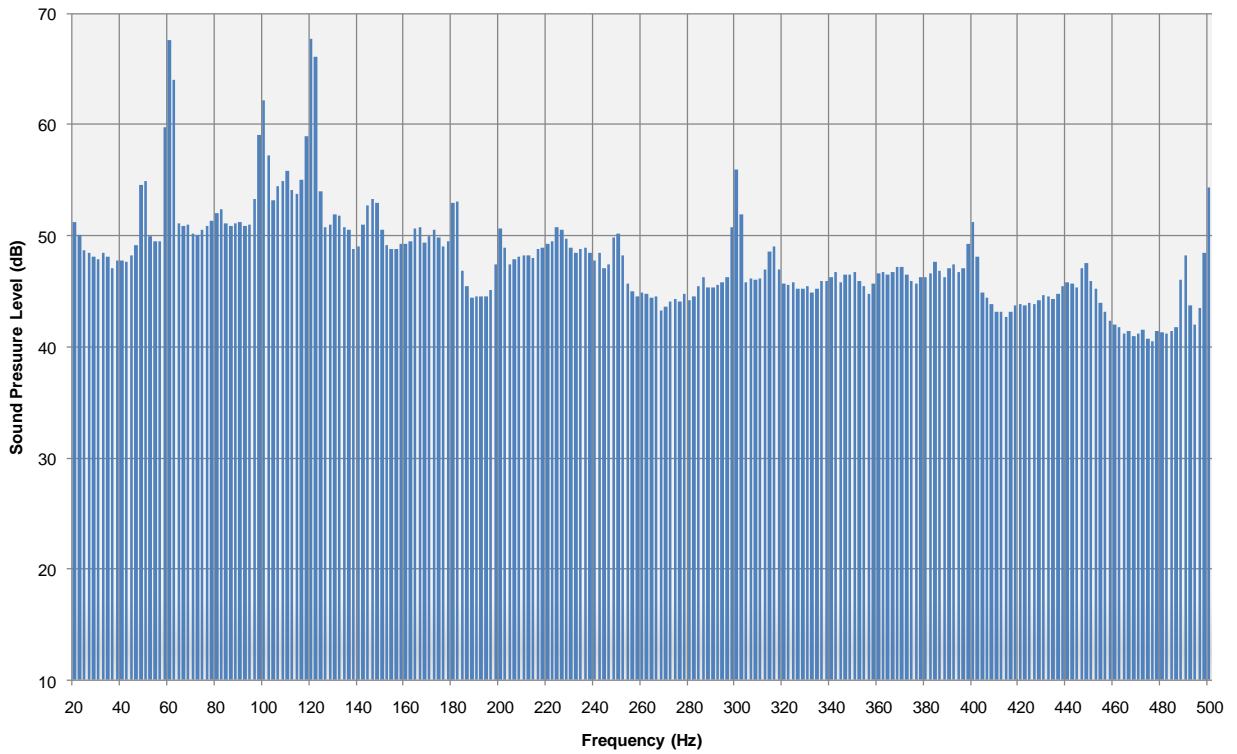

Figure 5-48. 443 Cheshire West, Sound Pressure Level Frequency Spectrum (Normal Operation)

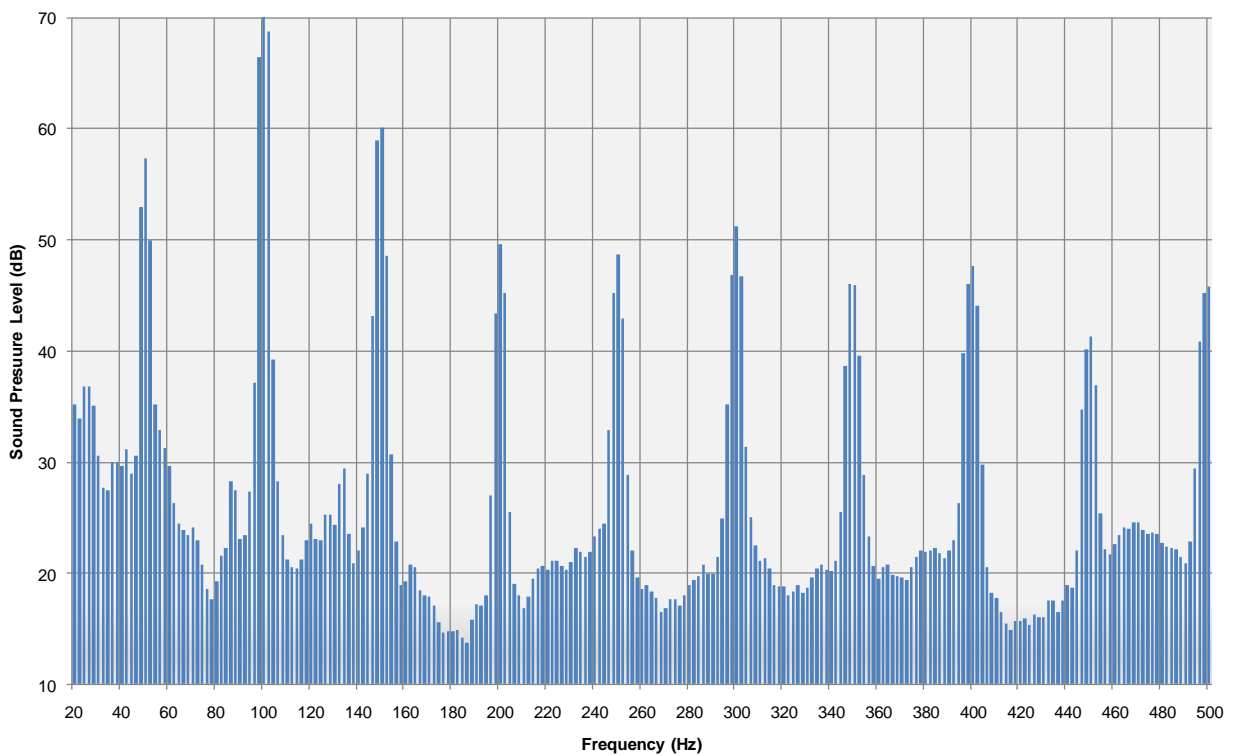
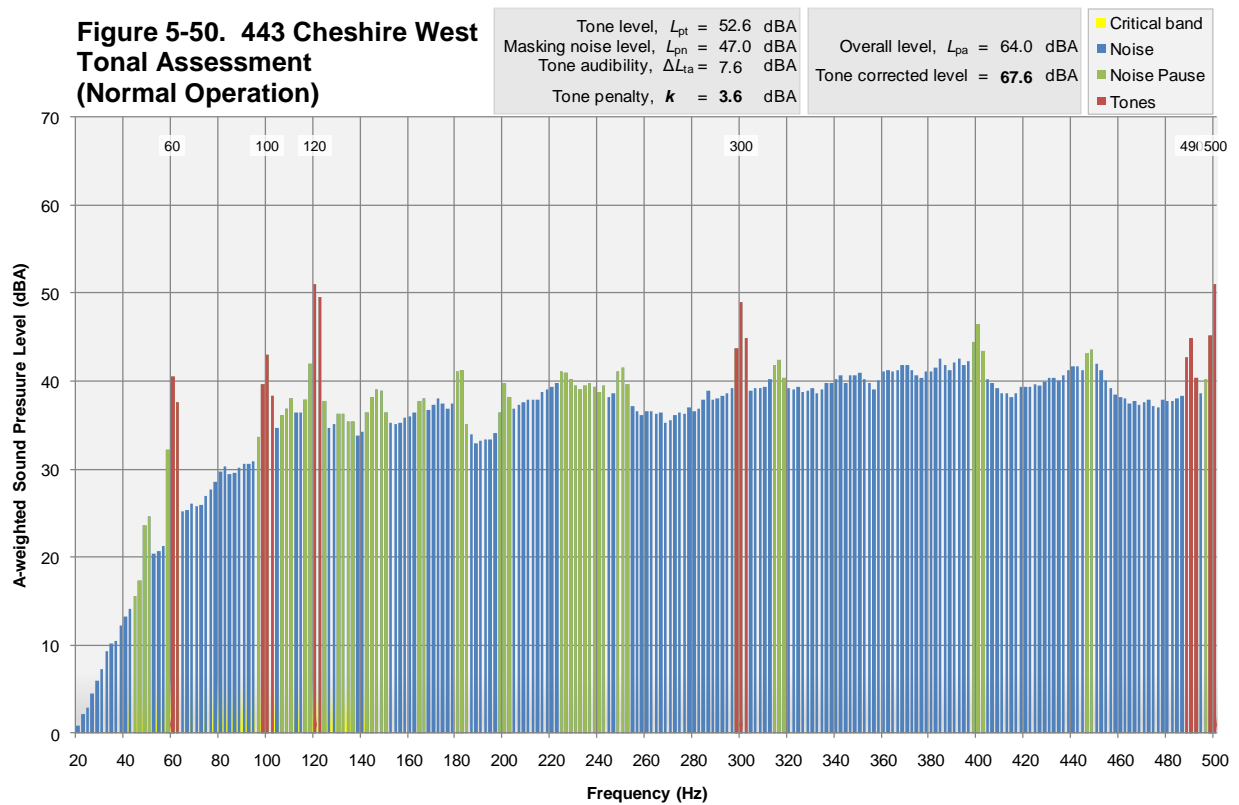
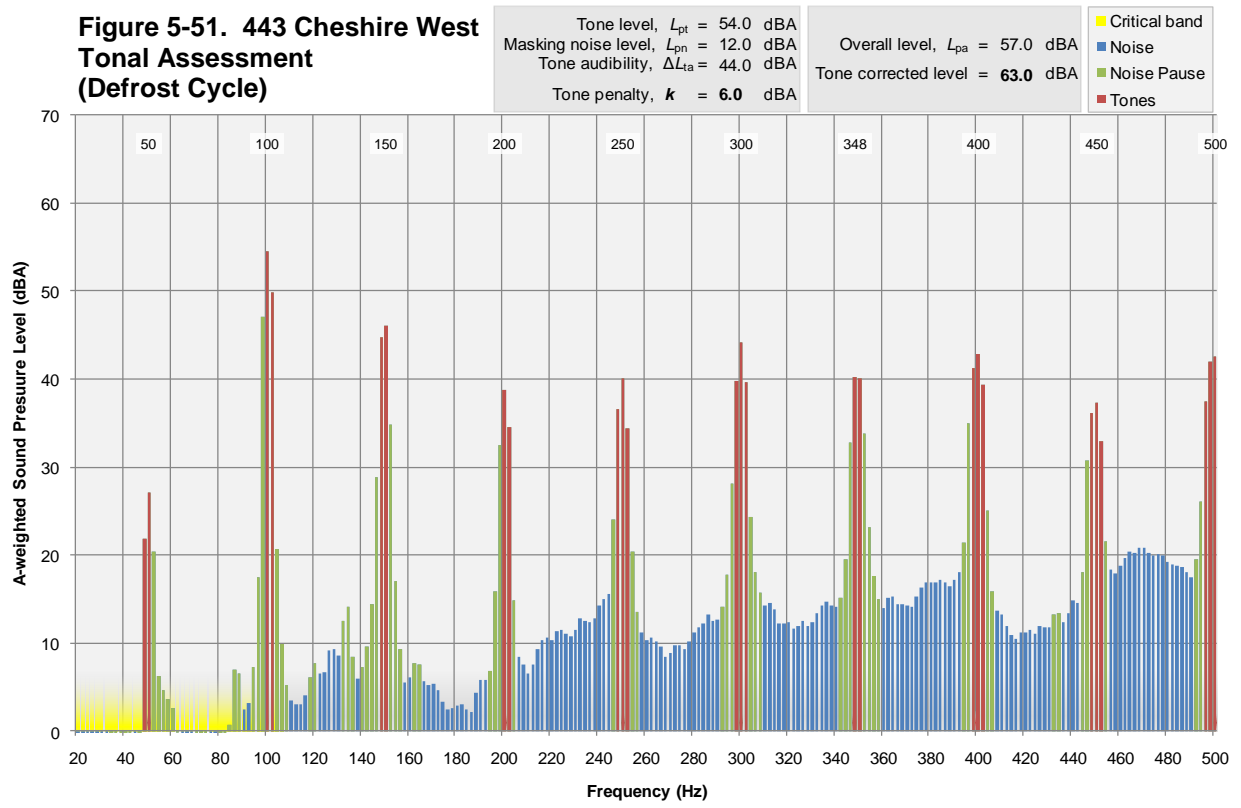

Figure 5-49. 443 Cheshire West, Sound Pressure Level Frequency Spectrum (Defrost cycle)

5.6.17. Tonal analysis of the frequency spectra shown in Figure 5-48 and Figure 5-49 has been undertaken in accordance with the Joint Nordic Method (v2). The resulting tonal assessments are presented in Figure 5-50 and Figure 5-51, showing that the tones identified within the spectrum would lead to a **4 dB tonal penalty** for normal operation and a **6 dB tonal penalty** for the defrost cycle.



**Figure 5-51. 443 Cheshire West
Tonal Assessment
(Defrost Cycle)**



Sound Power Level calculations

5.6.18. Figure 5-8 presents a statistical analysis plot of the percentage of time that a specific sound power level would be recorded, when the ASHP is under operation.

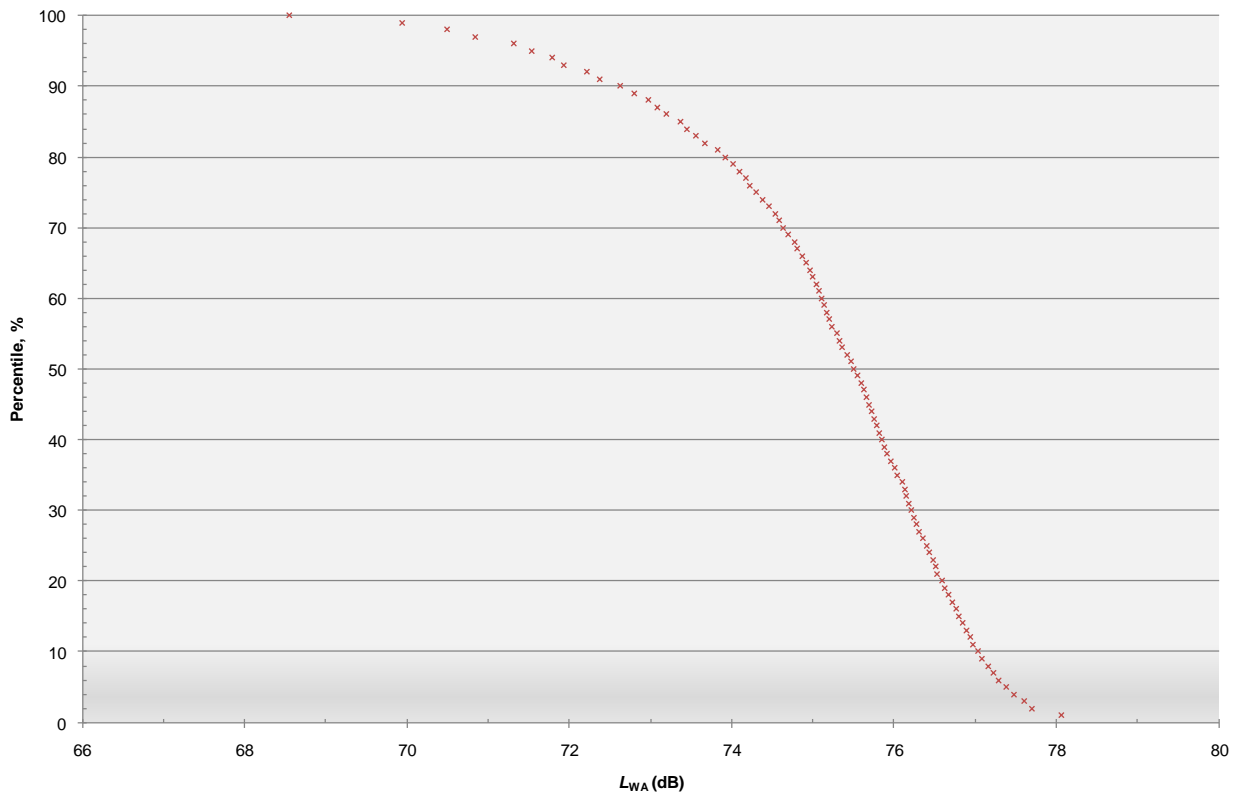

Figure 5-52. 443 Cheshire West, Sound Power Level Statistical Analysis

- 5.6.19. The chart indicates that noise from the ASHP during operation will have a 90% certainty of being within around 3 dB of L_{WA} **76 dB**.
- 5.6.20. Use of Equation 1 leads to an estimation that noise levels from the unit operating normally would drop to L_{Aeq} 42 dB at a distance separation of approximately **28 m**. If a tonal penalty were to be included, then this distance would rise to around **45 m**. This assumes that the ASHP is located in the common mounting scenario as detailed in Section 3.41, which is not necessarily representative of the actual measured condition.

Vibration

- 5.6.21. An FFT analysis of the vibration levels recorded for normal operation of the ASHP is shown in Figure 5-53. The overall weighted peak vibration level at the wall surface was 0.017 ms^{-2} , just above the average perception threshold for whole-body vibration.

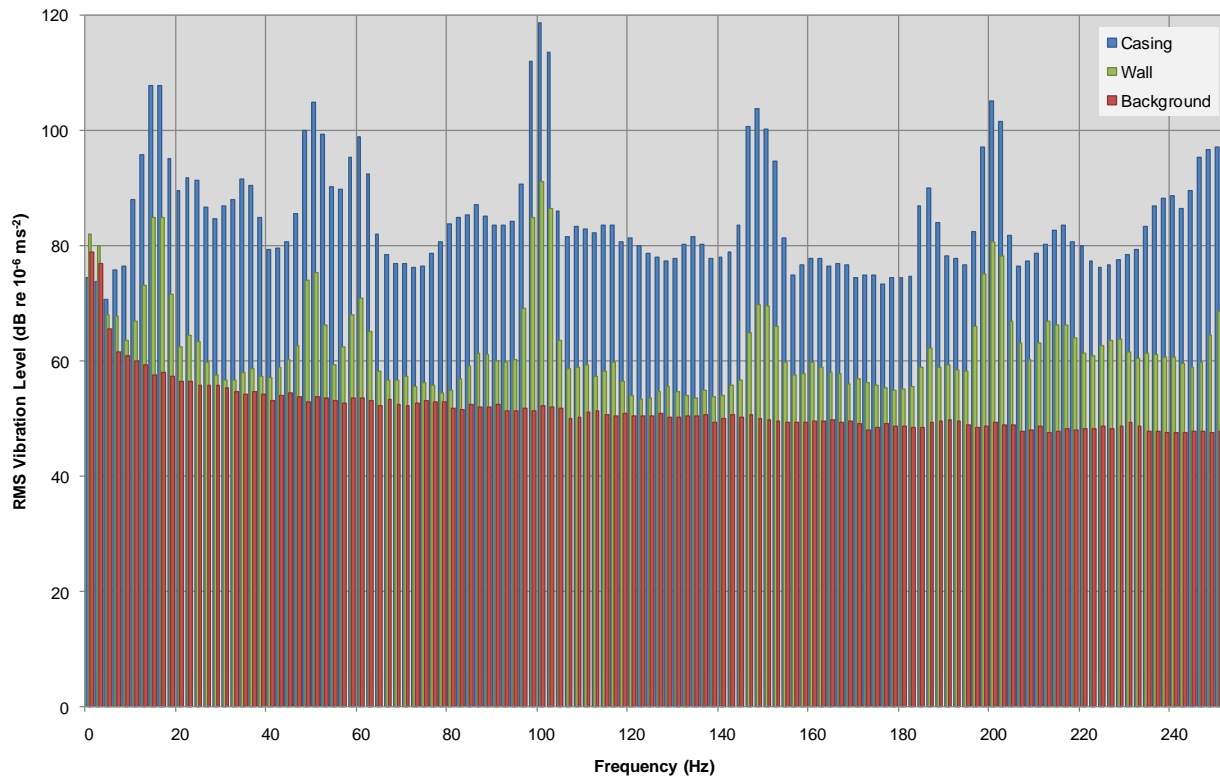

Figure 5-53. 443 Cheshire West, Vibration Levels

Discussion

- 5.6.22. The manufacturer has stated that the fan for ASHP rotates at a nominal speed of 903 rpm, with a compressor speed of 2900 rpm. With four fan blades, the blade passing frequency is around 60 Hz, with harmonics around 120 and 180 Hz. These are identified in the frequency spectrum for normal operation. The compressor speed corresponds to a frequency of around 50 Hz, with harmonics observed throughout the frequency range.
- 5.6.23. During normal operation, the fan provides a greater amount of noise than the compressor, although some tonal content from the compressor is audible.
- 5.6.24. The vibration data shows that both the compressor and fan contribute to the vibration levels, and there is good vibration attenuation between the casing and wall surface, due to the presence of the isolation mounts. It should be noted that the vibration level around 100 Hz is likely to cause some structure-borne noise to the inhabitants of the property.

5.7 **474 West Berkshire (Site 1)**

Site description

- 5.7.1. The property is located in a rural village off a quiet road. The ASHP is located to the rear of a modern brick built two story semi-detached property. The unit is seated on concrete footings, in front of the property wall.
- 5.7.2. Subjectively the unit appeared to be operating normally with no audible rattle, resonance or fault.

Equipment set up

- 5.7.3. The 5 Channel PULSE system was used at this site.
- 5.7.4. The ASHP was located on hard, reflective ground, with a fence panel situated close by, to the right of the unit.
- 5.7.5. An accelerometer was fixed to the unit casing, as shown in Picture 5-17, using cyanoacrylate cement.

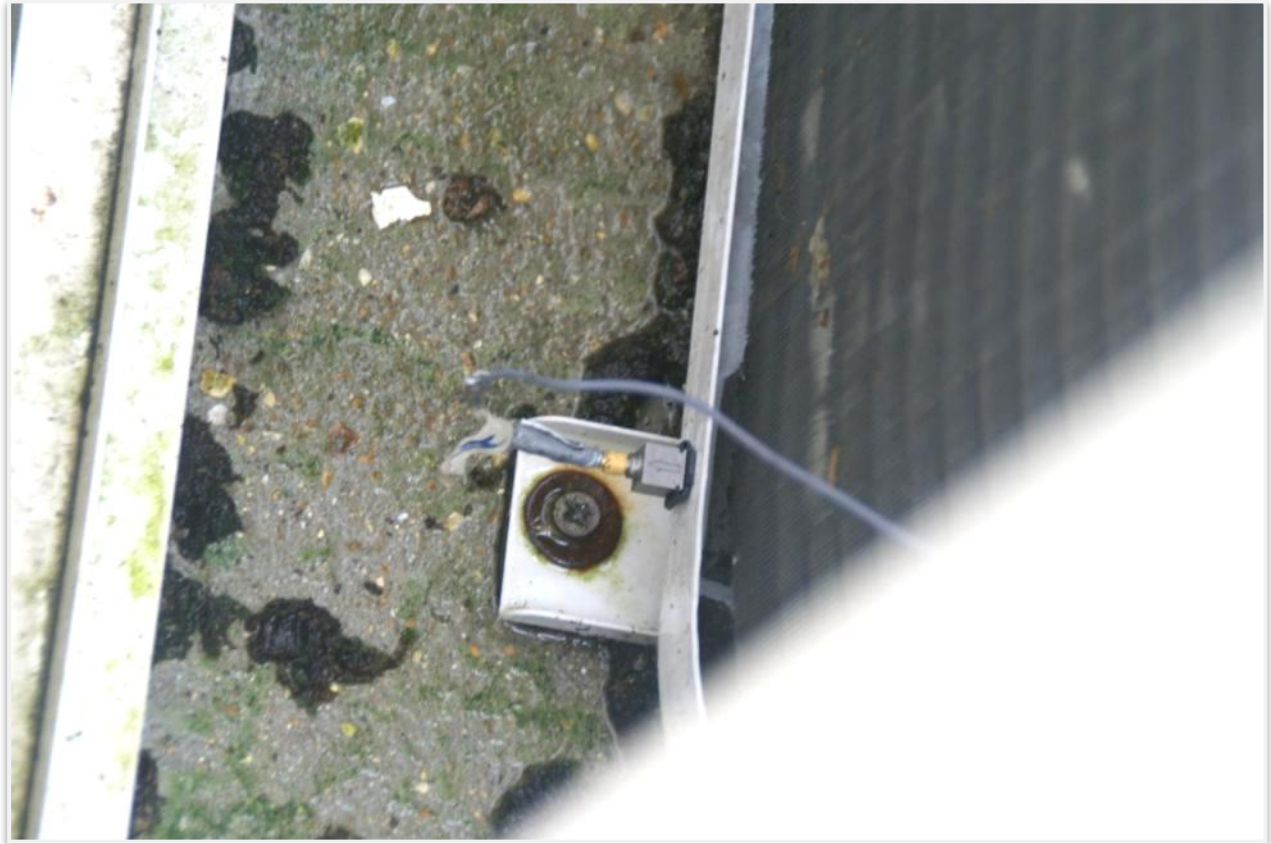

Picture 5-17. 474 West Berkshire (Site 1), Casing-mounted Accelerometer

5.7.6. Three microphones were used, two mounted on scaffolding and one mounted on a tripod as shown in Picture 5-18. All microphones were positioned 1 m from the ASHP casing, with the exception of the position to the right of the ASHP, which was situated slightly closer (60 cm) due to the presence of a walkway.



Picture 5-18. 474 West Berkshire (Site 1), ASHP and Microphone Arrangement

Measurement Results

- 5.7.7. Figure 5-54 presents the $L_{Aeq(1min)}$ measured noise levels at the microphone 1m in front of the unit set against time, along with the per-minute logged ASHP power consumption.

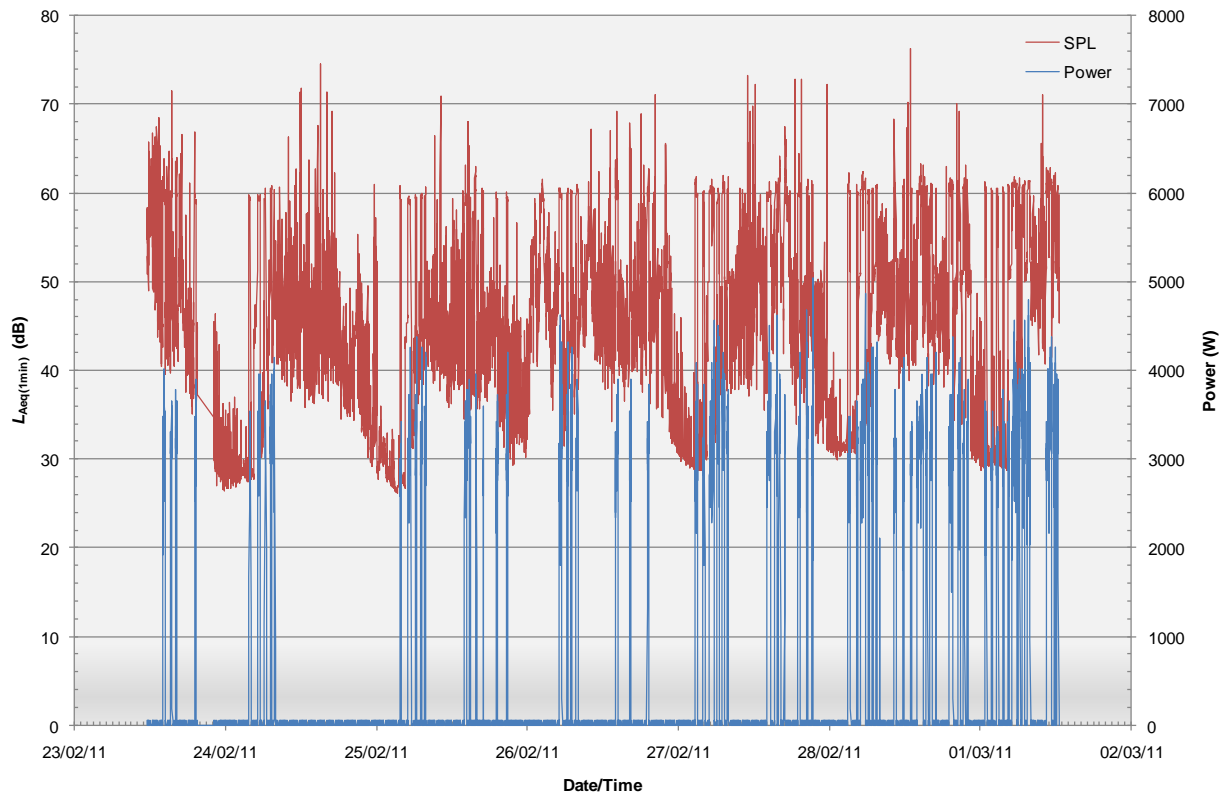

Figure 5-54. 474 West Berkshire (Site 1), Sound Pressure Level and Power Consumption vs Time

5.7.8. The chart highlights that the ASHP operates mainly over a morning period and an afternoon period. During these periods, the ASHP cycles on and off every hour or so; when the ASHP is operating, it does so for periods of 10-20 minutes. Throughout the measurement period, the ASHP was operating for approximately 15% of the time.

5.7.9. The trace shows an increase in measured noise level during periods when the ASHP is operating.

Measurement Analysis

5.7.10. Figure 5-55 presents a scatter diagram showing the noise levels against the power consumption, for the periods when the ASHP was operating. The chart trend line indicates a slight increase in noise level with ASHP power level, although the fit is not conclusive, with a regression coefficient (r^2) of just 4%.

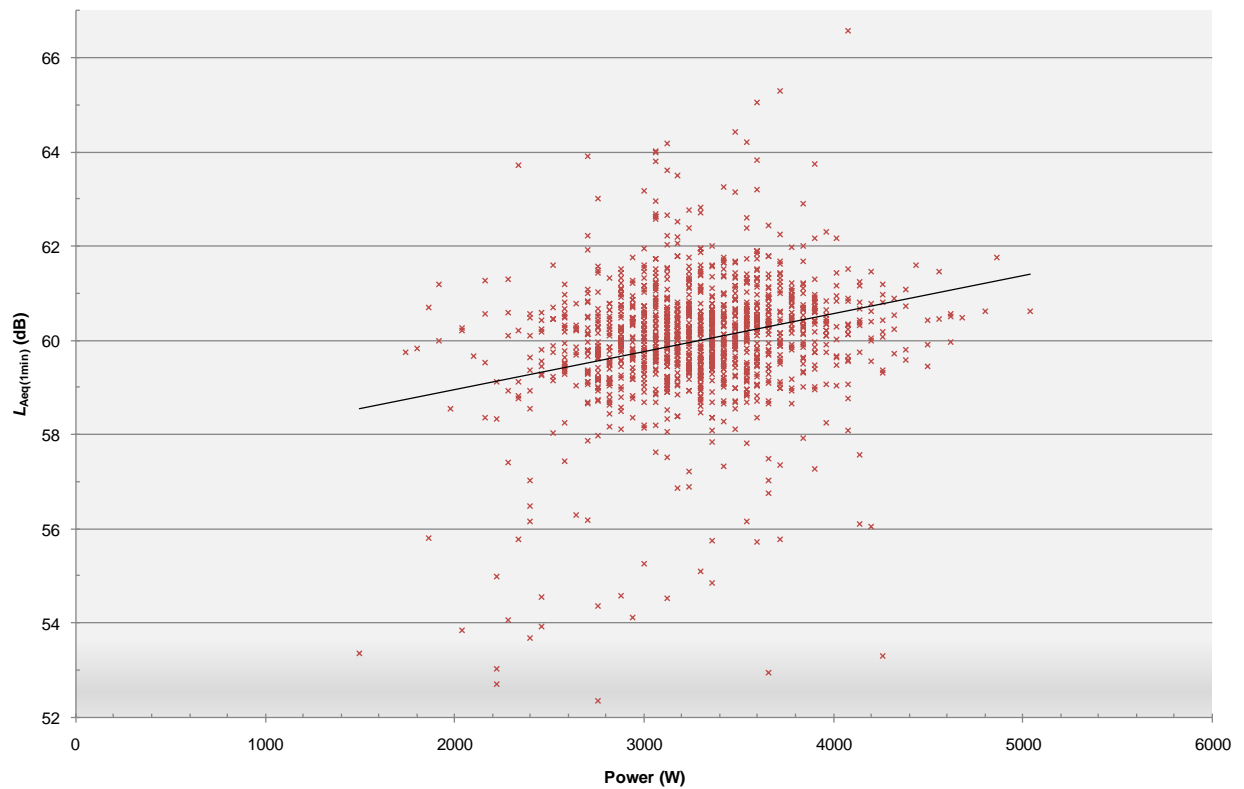

Figure 5-55. 474 West Berkshire (Site 1), Sound Pressure Level vs Power Consumption

5.7.11. Figure 5-56 presents a statistical analysis plot of the percentage of time that a specific noise level would be recorded, when the ASHP is under operation. From this confidence intervals can be presented for the typical noise levels.

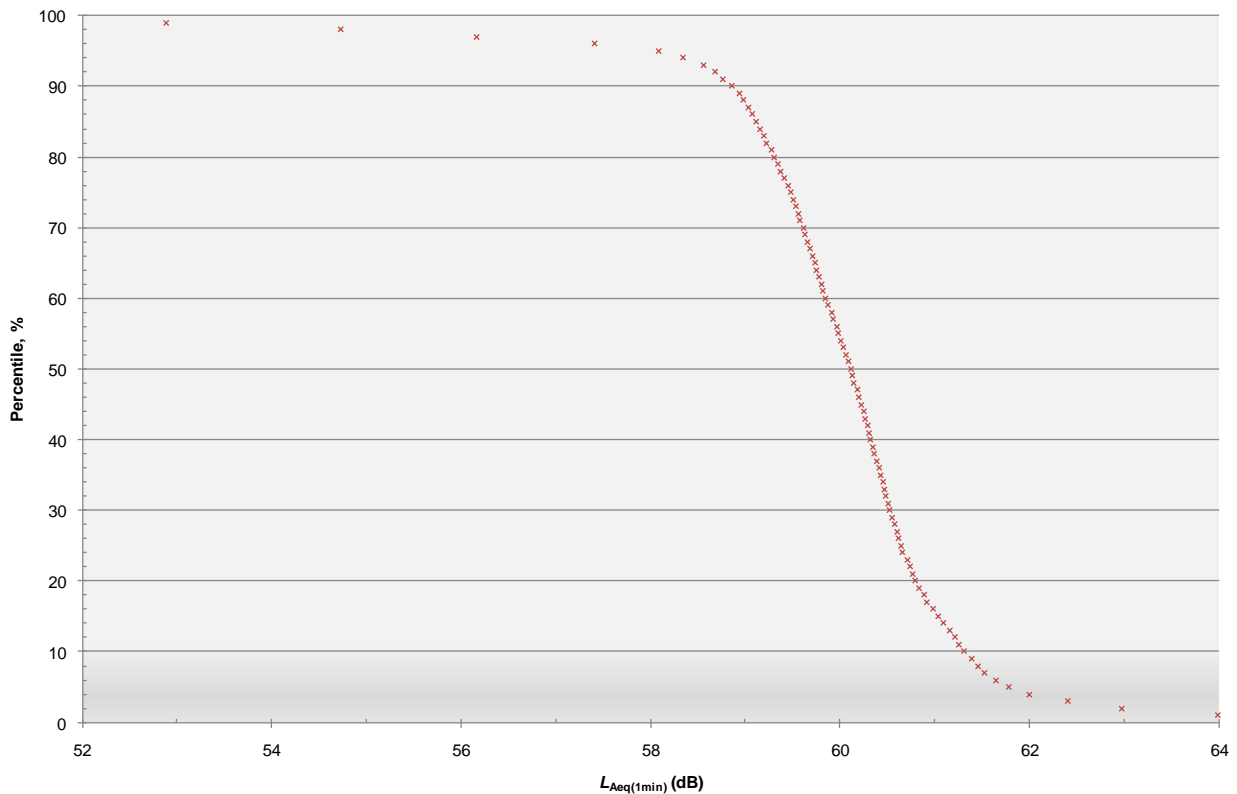

Figure 5-56. 474 West Berkshire (Site 1), Sound Pressure Level Statistical Analysis

- 5.7.12. The chart indicates that noise from the ASHP during operation will have a 90% certainty of being within around 2 dB of $L_{Aeq(1min)}$ **60 dB**. The corresponding total ASHP noise dose over the whole assessment period is calculated as $L_{Aeq(1week)}$ **52 dB**.

Defrost Cycle

- 5.7.13. Analysis of the measurements revealed that defrost cycles are part of the ASHP operation. During these periods, which can last for 1 to 2 minutes, the compressor is operating in reverse, without the fan. The average sound pressure level during a typical defrost cycle is around $L_{Aeq(1min)}$ **51 dB**.

Directivity

5.7.14. Table 5-7 shows the directivity in noise emissions from the unit by comparing the noise levels at the different microphones, for a typical period of ASHP operation.

Table 5-7: Directivity Analysis of the ASHP Noise Emissions $L_{Aeq(1min)}$ dB 474 West Berkshire (Site 1), normal operation			
Microphone Location	Front	Left	Above
Typical Microphone Level	60	61	58
Change from front microphone	-	+1	-2

5.7.15. It is seen that the ASHP is not significantly directional, which is likely to be due to the nearby acoustically reflective surfaces.

Frequency analysis

5.7.16. For the frequency analysis, a Fast Fourier Transform (FFT) of the signal was performed, averaged over a representative one minute period at a frequency resolution of 2 Hz. The resulting frequency spectrum for the ASHP operating under normal conditions is given in Figure 5-57, with that for the defrost cycle presented in Figure 5-58.

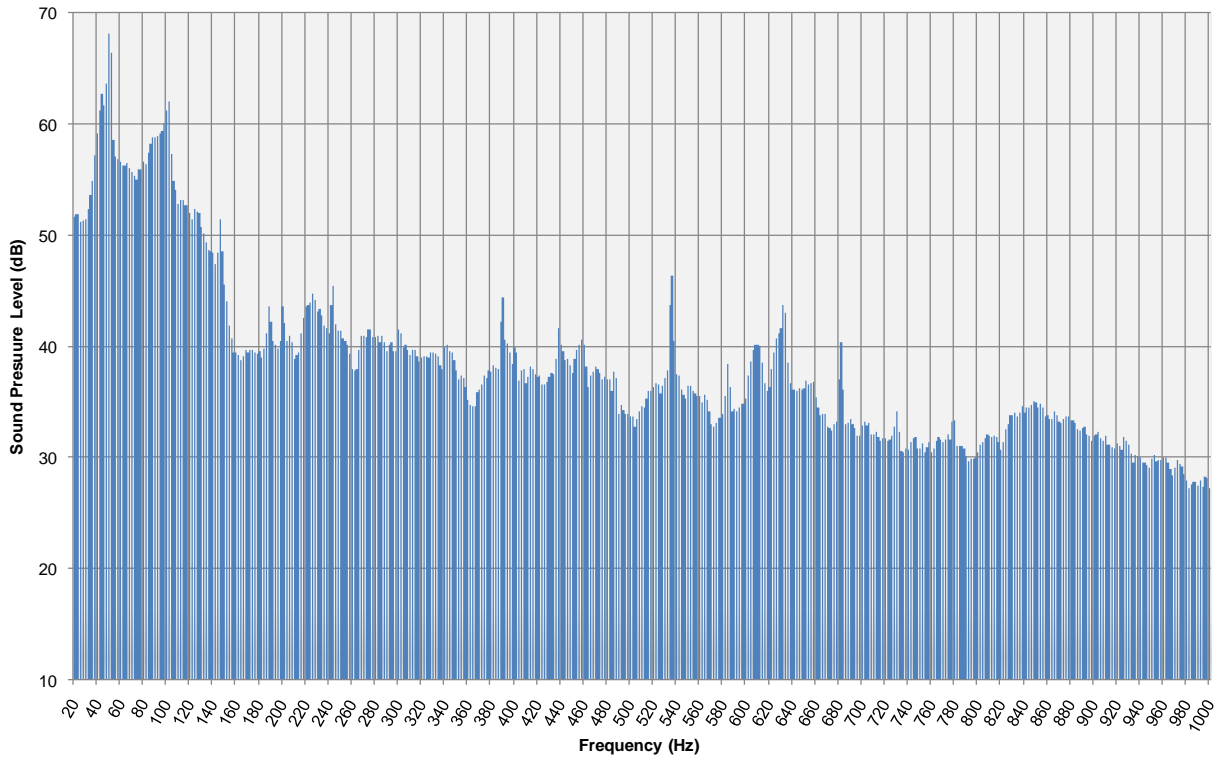

Figure 5-57. 474 West Berkshire (Site 1), SPL Spectrum (Normal Operation)

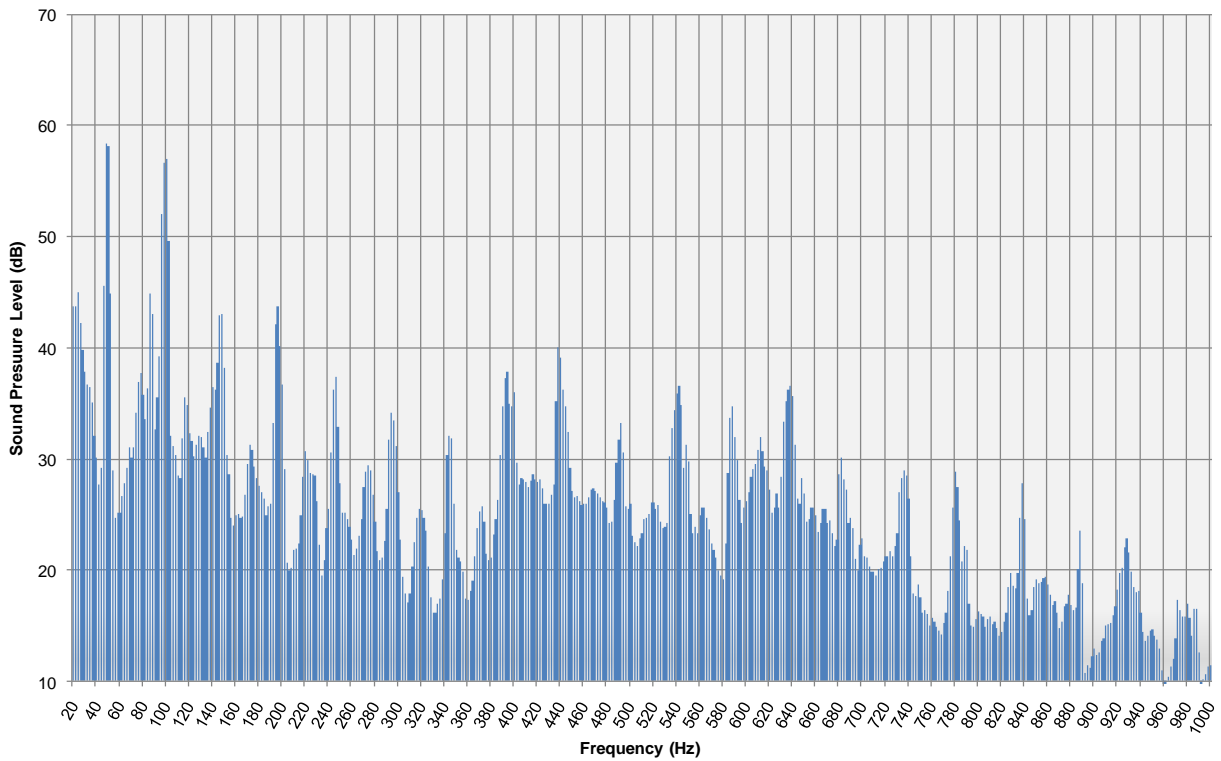
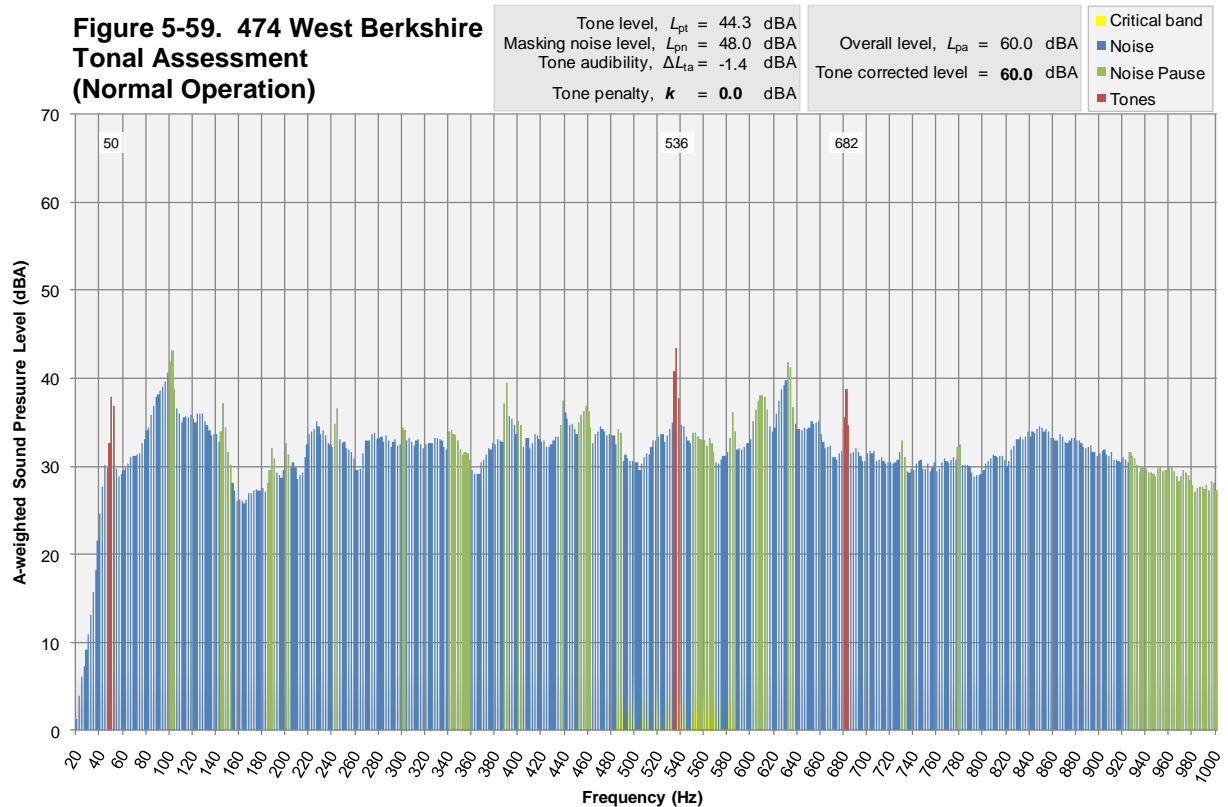
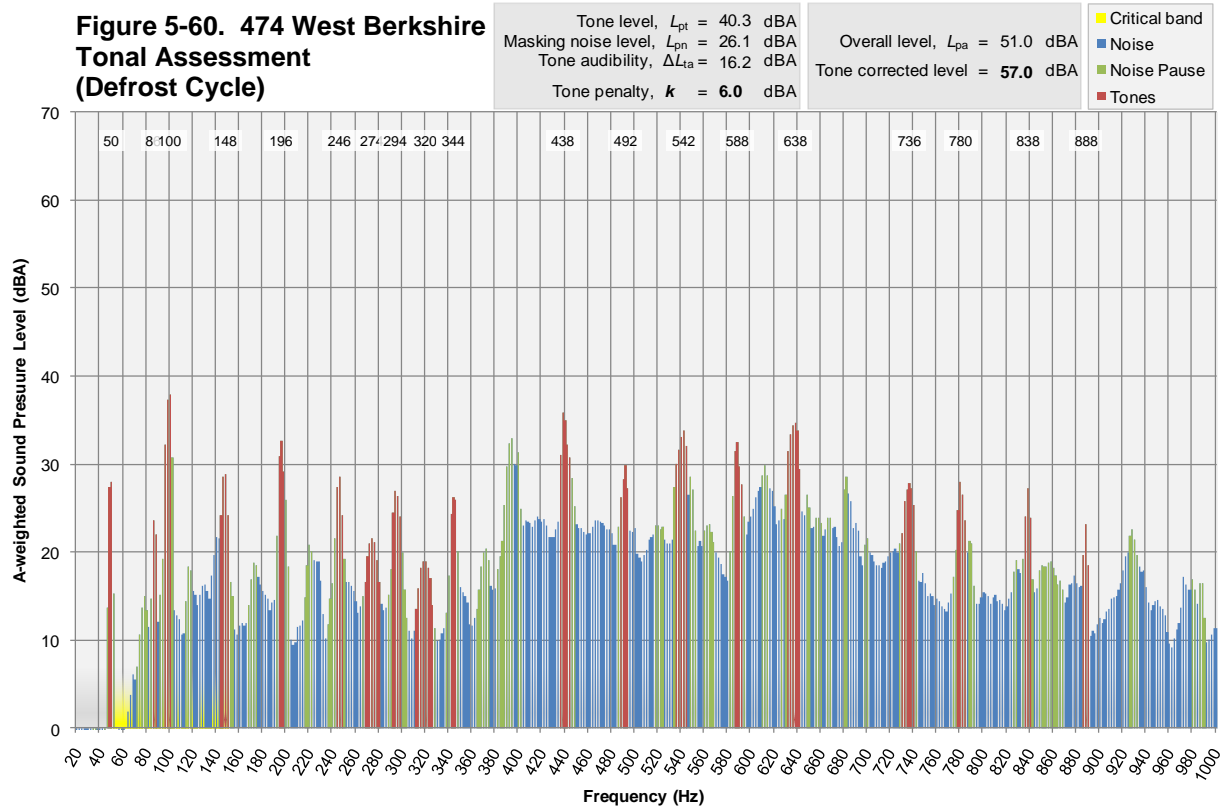

Figure 5-58. 474 West Berkshire (Site 1), SPL Spectrum (Defrost Cycle)

5.7.17. Tonal analysis of the frequency spectra shown in Figure 5-57 and Figure 5-58 has been undertaken in accordance with the Joint Nordic Method (v2). The resulting tonal assessments are presented in Figure 5-59 and Figure 5-60, showing that the tones identified within the spectrum for normal operation would lead to a **0 dB tonal penalty**. During the defrost cycle, the tonal assessment indicates that a **6 dB tonal penalty** would be appropriate.



**Figure 5-60. 474 West Berkshire
Tonal Assessment
(Defrost Cycle)**



Sound Power Level calculations

5.7.18. Figure 5-61 presents a statistical analysis plot of the percentage of time that a specific sound power level would be recorded, when the ASHP is under operation.

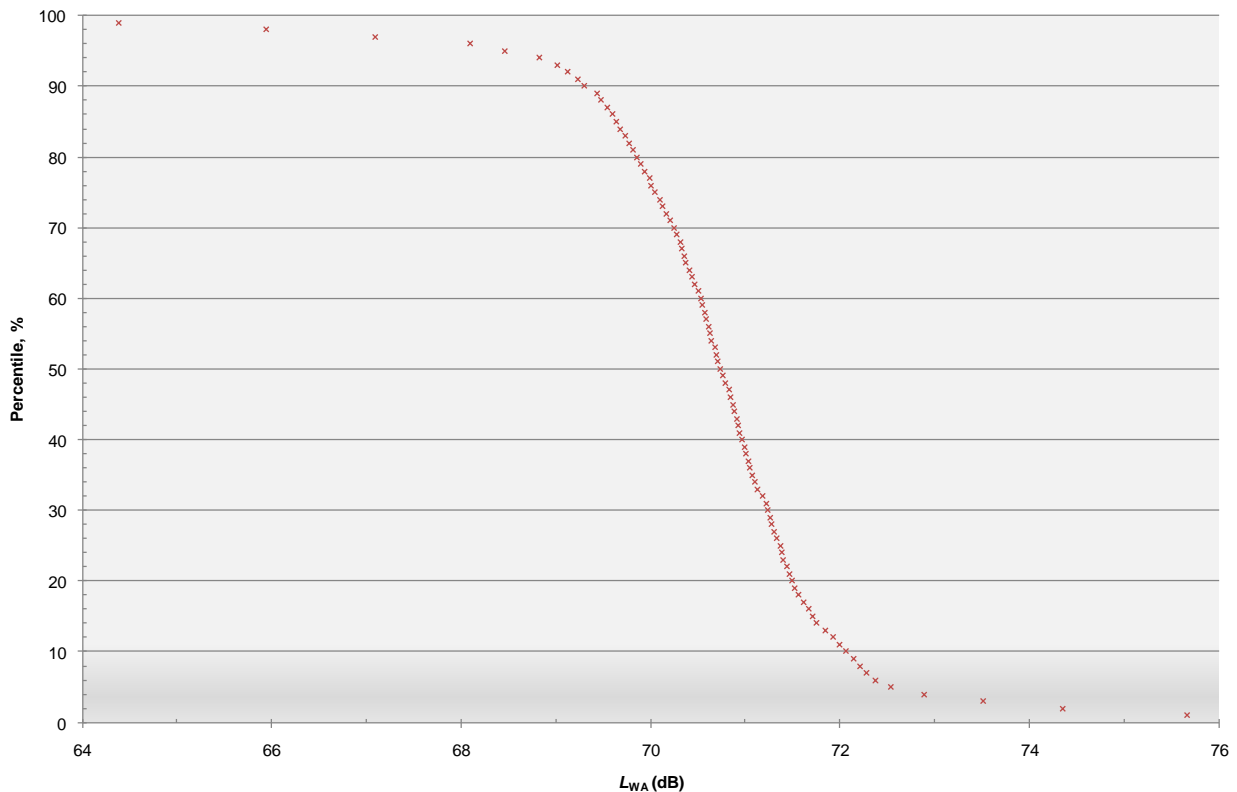

Figure 5-61. 474 West Berkshire (Site 1), Sound Power Level Statistical Analysis

- 5.7.19. The chart indicates that noise from the ASHP during operation will have a 90% certainty of being within around 2 dB of L_{WA} 71 dB.
- 5.7.20. Use of Equation 1 leads to an estimation that noise levels from the unit operating normally would drop to L_{Aeq} 42 dB at a distance separation of approximately **16 m**. This assumes that the ASHP is located in the common mounting scenario as detailed in Section 3.41, which is not necessarily representative of the actual measured condition.

Vibration

- 5.7.21. An FFT analysis of the vibration levels recorded for normal operation of the ASHP is shown in Figure 5-62. The peaks in the background spectrum at 100 and 200 Hz are deemed to be due to an electrical component within the ASHP.

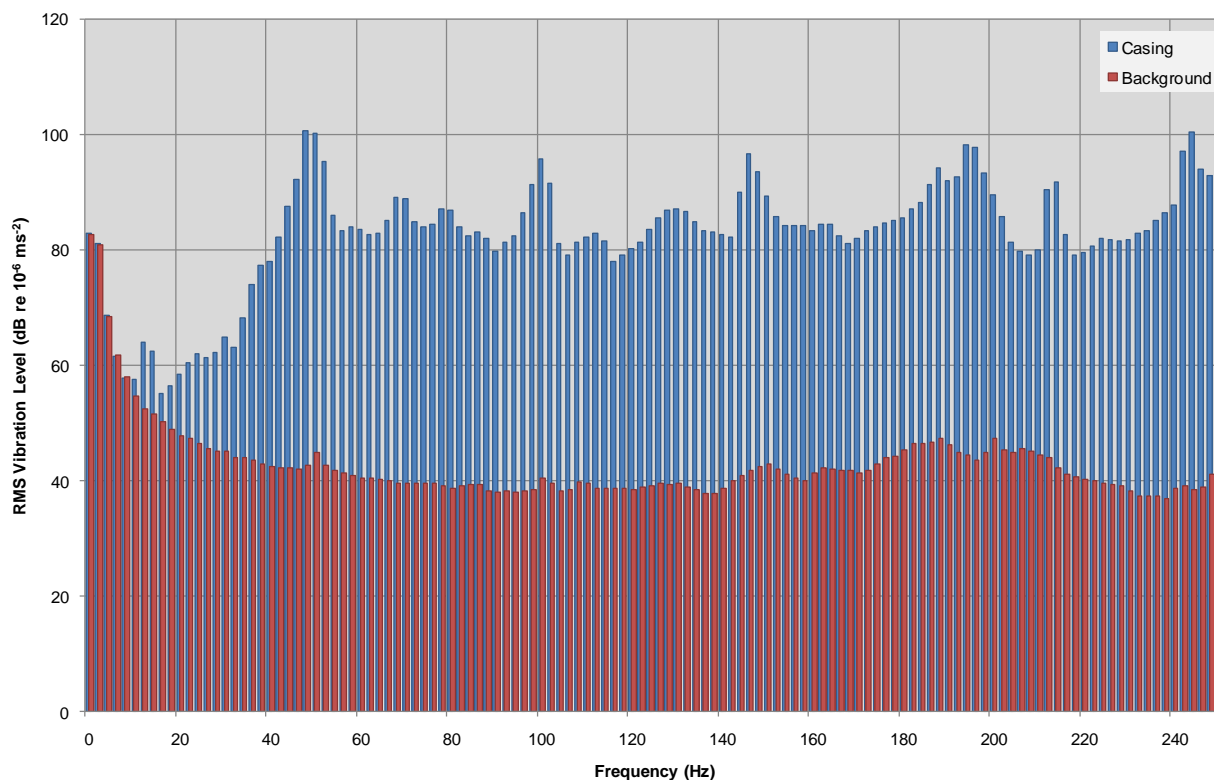

Figure 5-62. 474 West Berkshire (Site 1), Vibration Levels

Discussion

- 5.7.22. The manufacturer has indicated that the speed rating of the fan is nominally 770 rpm, and the compressor speed is 2850 rpm. With four fan blades, the passing frequency would correspond to around 51 Hz, with upper harmonics around 102 and 153 Hz. These are seen in the frequency spectrum results of normal operation. The compressor speed corresponds with a rotation frequency of around 48 Hz, upper harmonics are clearly visible in the defrost cycle frequency spectrum.
- 5.7.23. During normal operation, the fan contributes a greater amount of noise than the compressor, although tonal content provided by the compressor is audible.
- 5.7.24. The vibration data shows that both the compressor and fan contribute to the vibration emissions.

5.8 *475 West Berkshire (Site 2)*

Site description

- 5.8.1. The property is located in a small village off a quiet road. The ASHP is located to the rear of the brick built two story end of terrace property. The unit is mounted onto concrete paving slab footings.
- 5.8.2. Subjectively the unit appeared to be operating normally although a prominent rattle was heard at times.

Equipment set up

- 5.8.3. The 9 Channel PULSE system was used at this site.
- 5.8.4. The unit was mounted above a mixed ground surface of soil, gravel and paving slabs. A garden storage unit was located to the right of the unit, preventing the installation of a microphone to the right of the ASHP. A fence was located to the left of the unit, which limited the distance at which the microphone could be placed at this location.
- 5.8.5. Accelerometers were fixed to the unit casing and to the wall surface immediately behind the unit as shown in Picture 5-19 and Picture 5-20. The accelerometers were fixed to the surfaces using cyanoacrylate cement.



Picture 5-19. 475 West Berkshire (Site 2), Casing-mounted Accelerometer

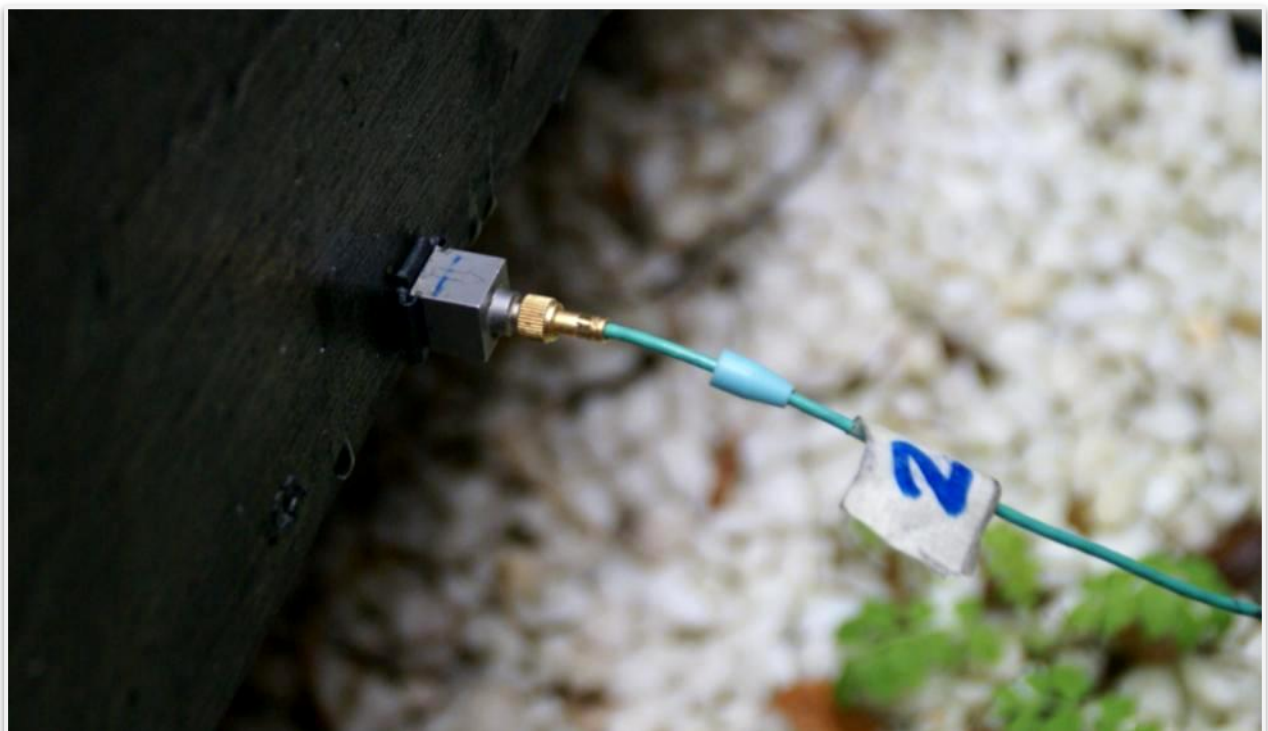

Picture 5-20. 475 West Berkshire (Site 2), Wall-mounted Accelerometer

5.8.6. The microphones were mounted on tripods as shown in Picture 5-21. All microphones were positioned 1 m from the ASHP casing, with the exception of the microphone to the left, which had a separation of 60 cm.



Picture 5-21. 475 West Berkshire (Site 2), ASHP and Microphone Arrangement

Measurement Results

- 5.8.7. Figure 5-63 presents the $L_{Aeq(1min)}$ measured noise levels at the microphone 1m in front of the unit set against time, along with the per-minute logged ASHP power consumption.

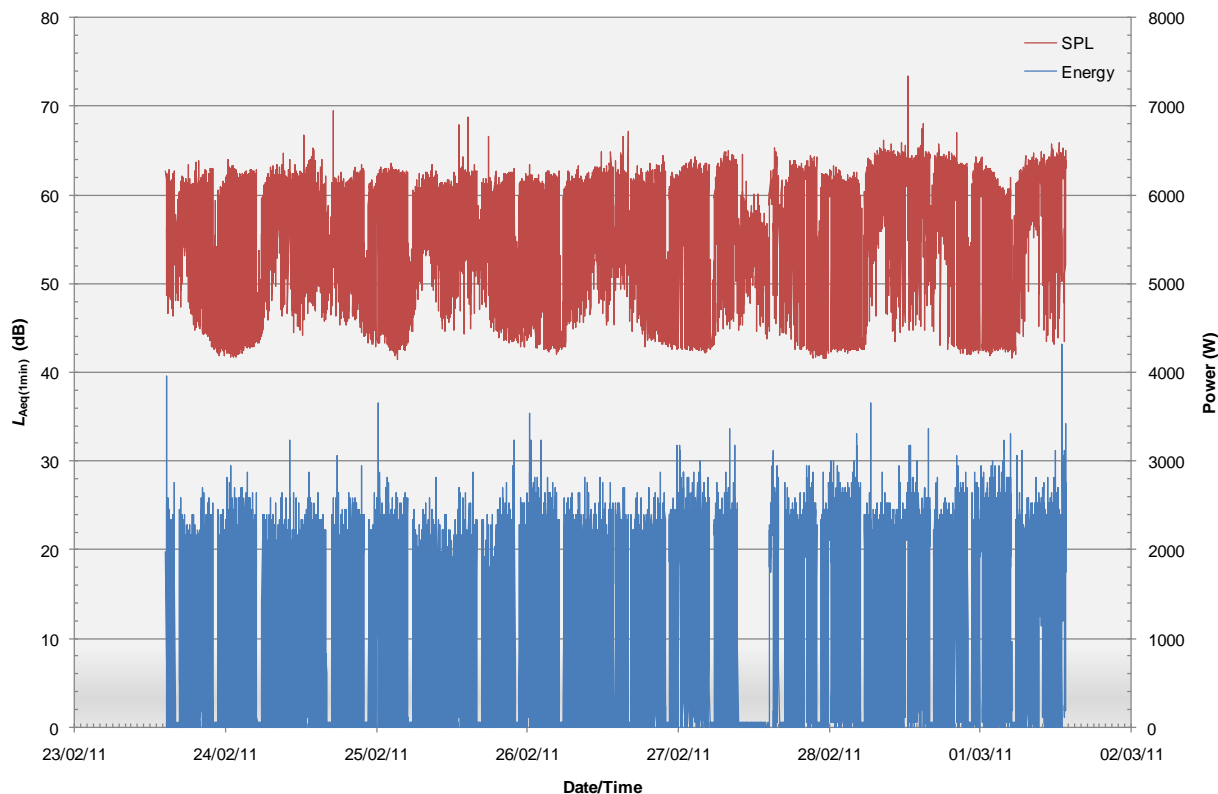

Figure 5-63. 475 West Berkshire (Site 2), Sound Pressure Level and Power Consumption vs Time

5.8.8. The chart highlights that the ASHP is cycling on and off very frequently, approximately every ten minutes, throughout the day and night time periods. When the unit is operational, it is usually on for approximately three to four minutes. Throughout the measurement period, the ASHP was operational for approximately 33% of the time.

5.8.9. The data shows an increase in measured noise level during periods when the ASHP is operating.

Measurement Analysis

5.8.10. Figure 5-64 presents a scatter diagram showing the noise levels against the power consumption, for the periods when the ASHP was operating. The chart shows no apparent link between power and noise level.

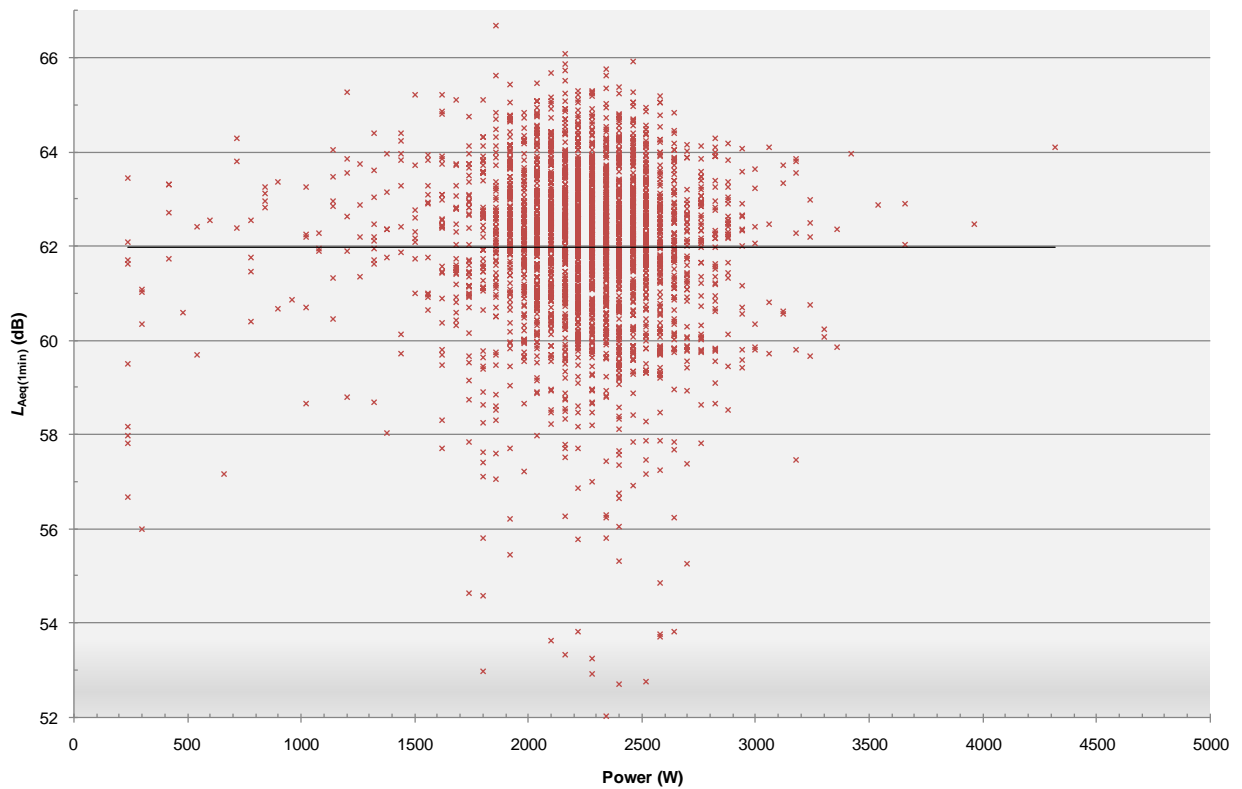

Figure 5-64. 475 West Berkshire (Site 2), Sound Pressure Level vs Power Consumption

5.8.11. Figure 5-65 presents a statistical analysis plot of the percentage of time that a specific noise level would be recorded, when the ASHP is under operation. From this confidence intervals can be presented for the typical noise levels.

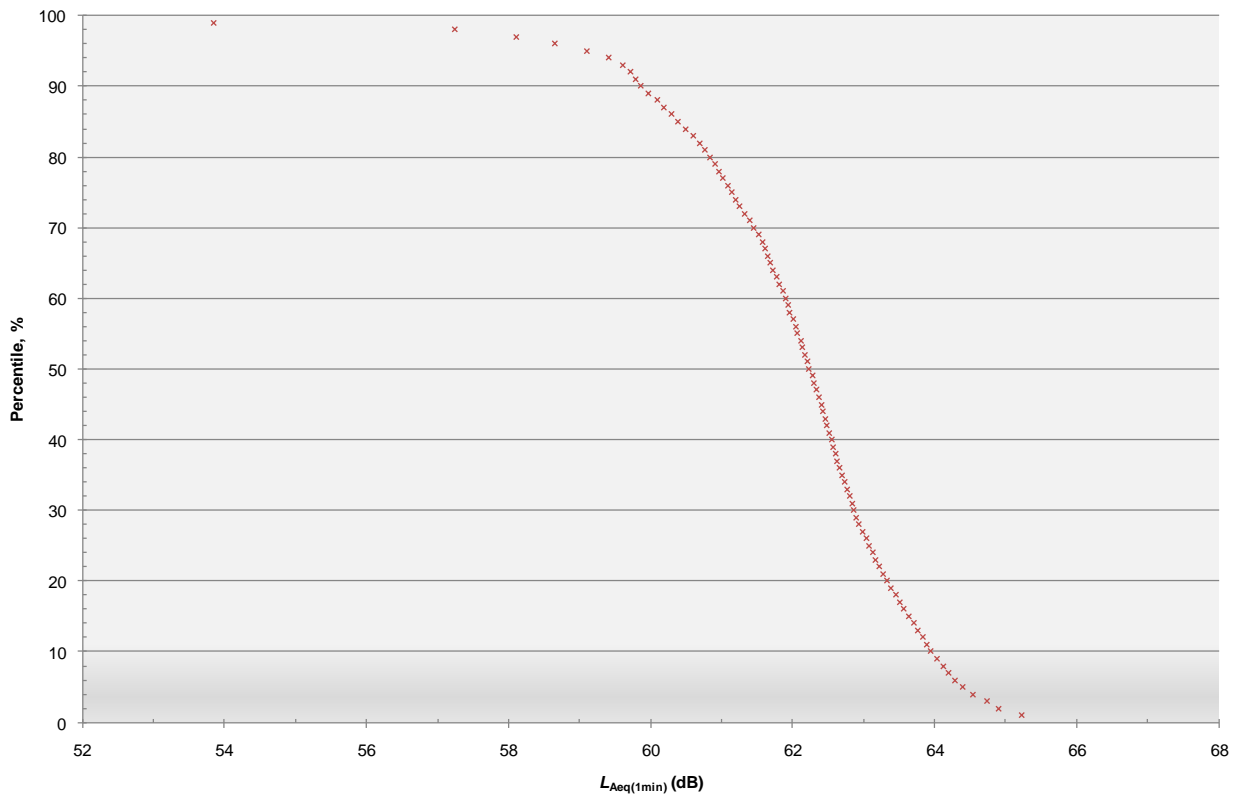

Figure 5-65. 475 West Berkshire (Site 2), Sound Pressure Level Statistical Analysis

5.8.12. The chart indicates that noise from the ASHP during operation will have a 90% certainty of being within around 3 dB of $L_{Aeq(1min)}$ **62 dB**. The corresponding total ASHP noise dose over the whole assessment period is calculated as $L_{Aeq(1week)}$ **57 dB**.

Defrost Cycle

5.8.13. Analysis of the measurements revealed that defrost cycles are part of the ASHP operation. During these periods, which can last for 2 to 3 minutes, the compressor is operating in reverse, without the fan. The average sound pressure level during a typical defrost cycle is around $L_{Aeq(1min)}$ **63 dB**.

Directivity

5.8.14. Table 5-8 shows the directivity in noise emissions from the unit by comparing the noise levels at the different microphones, for a typical period of ASHP operation.

Table 5-8: Directivity Analysis of the ASHP Noise Emissions $L_{Aeq(1min)}$ dB 475 West Berkshire (Site 2), normal operation			
Microphone Location	Front	Left	Above
Typical Microphone Level	62	62	62
Change from front microphone	-	0	0

5.8.15. It is seen that the ASHP does not exhibit significant directivity, which is likely to be due in part to the acoustically reflective nature of the nearby fence and garden storage unit.

Frequency analysis

5.8.16. For the frequency analysis, a Fast Fourier Transform (FFT) of the signal was performed, averaged over a representative one minute period at a frequency resolution of 2 Hz. The resulting frequency spectrum for the ASHP operating under normal conditions is given in Figure 5-66, with that for the defrost cycle given in Figure 5-67.

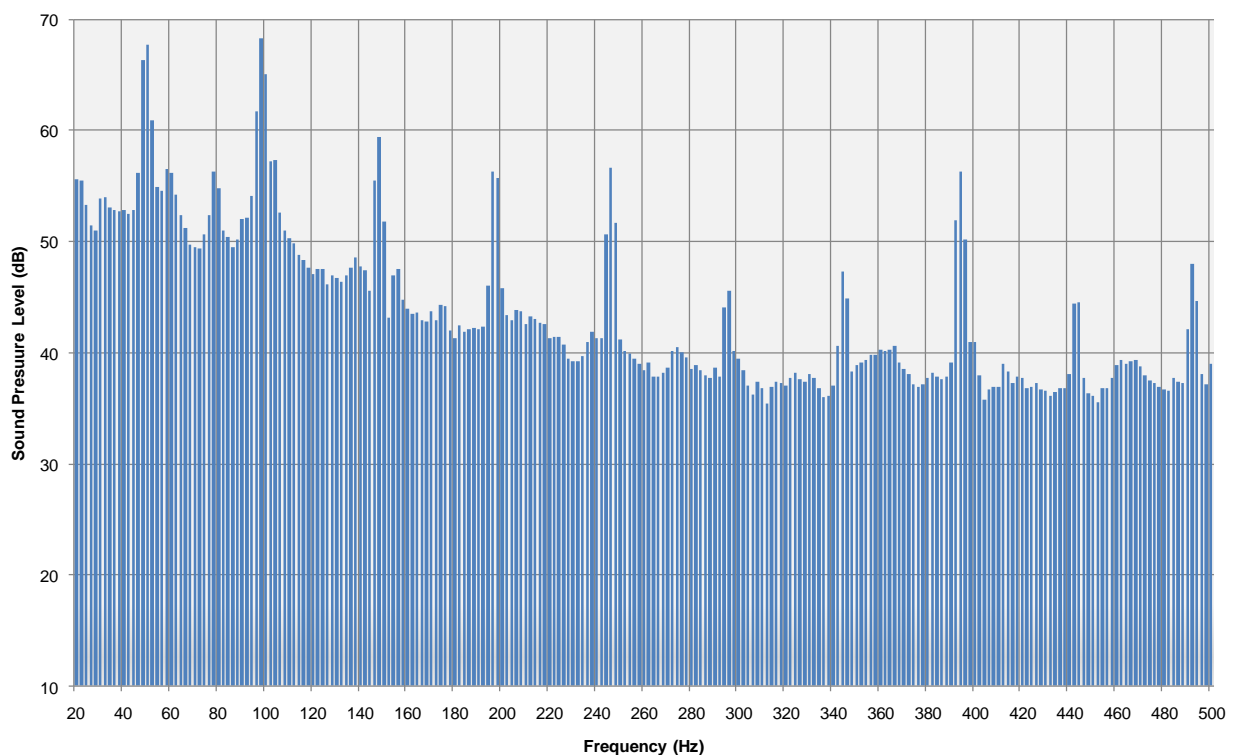

Figure 5-66. 475 West Berkshire (Site 2), Sound Pressure Level Frequency Spectrum (Normal Operation)

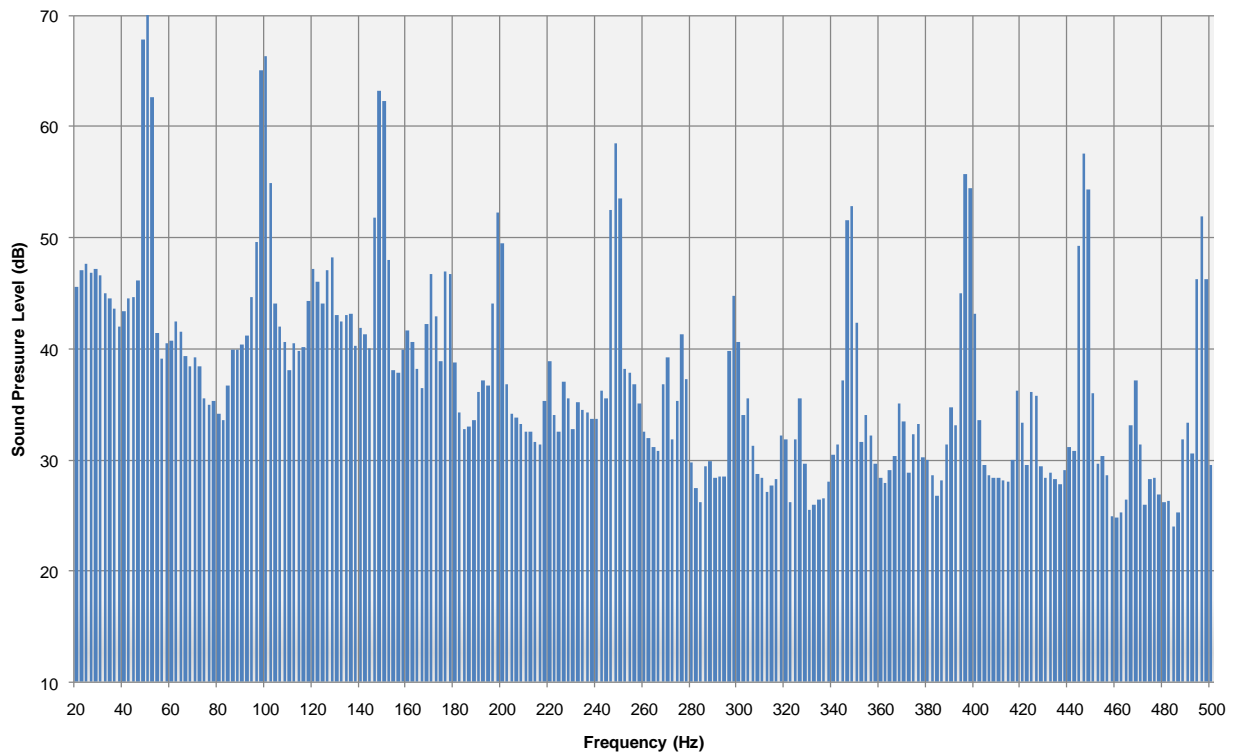
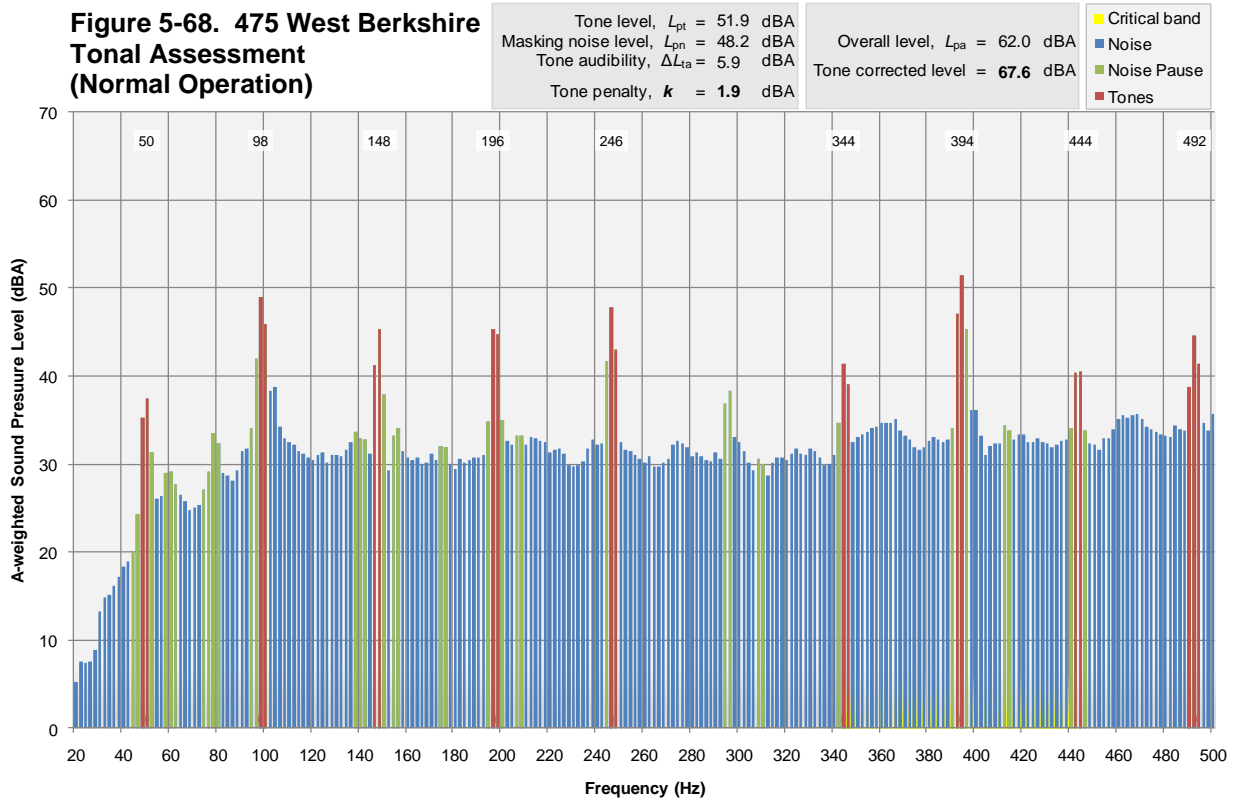

Figure 5-67. 475 West Berkshire (Site 2), Sound Pressure Level Frequency Spectrum (Defrost cycle)

5.8.17. Tonal analysis of the frequency spectra shown in Figure 5-66 and Figure 5-67 has been undertaken in accordance with the Joint Nordic Method (v2). The resulting tonal assessments are presented in Figure 5-68 and Figure 5-69, showing that the tones identified within the spectrum would lead to a **2 dB tonal penalty** for normal operation and a **6 dB tonal penalty** for the defrost cycle.

**Figure 5-68. 475 West Berkshire
Tonal Assessment
(Normal Operation)**



**Figure 5-69. 475 West Berkshire
Tonal Assessment
(Defrost Cycle)**

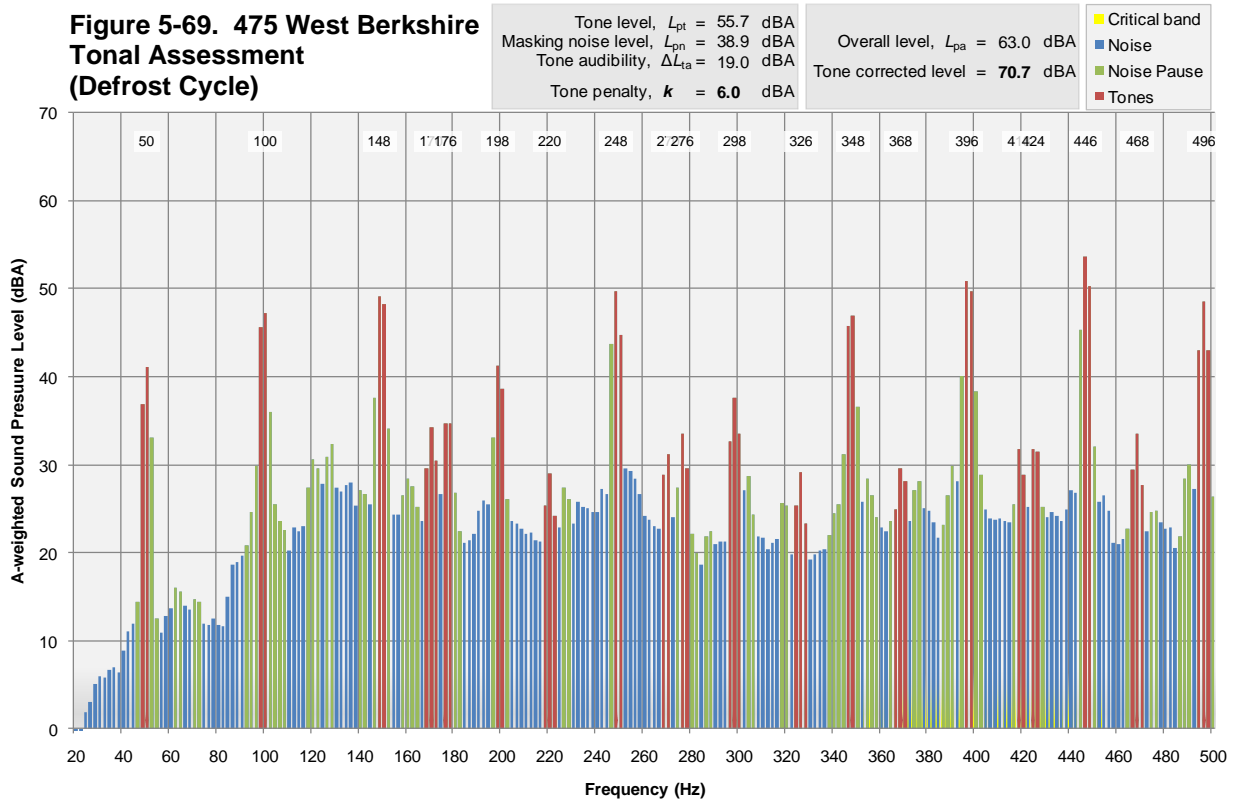

Sound Power Level calculations

5.8.18. Figure 5-8 presents a statistical analysis plot of the percentage of time that a specific sound power level would be recorded, when the ASHP is under operation.

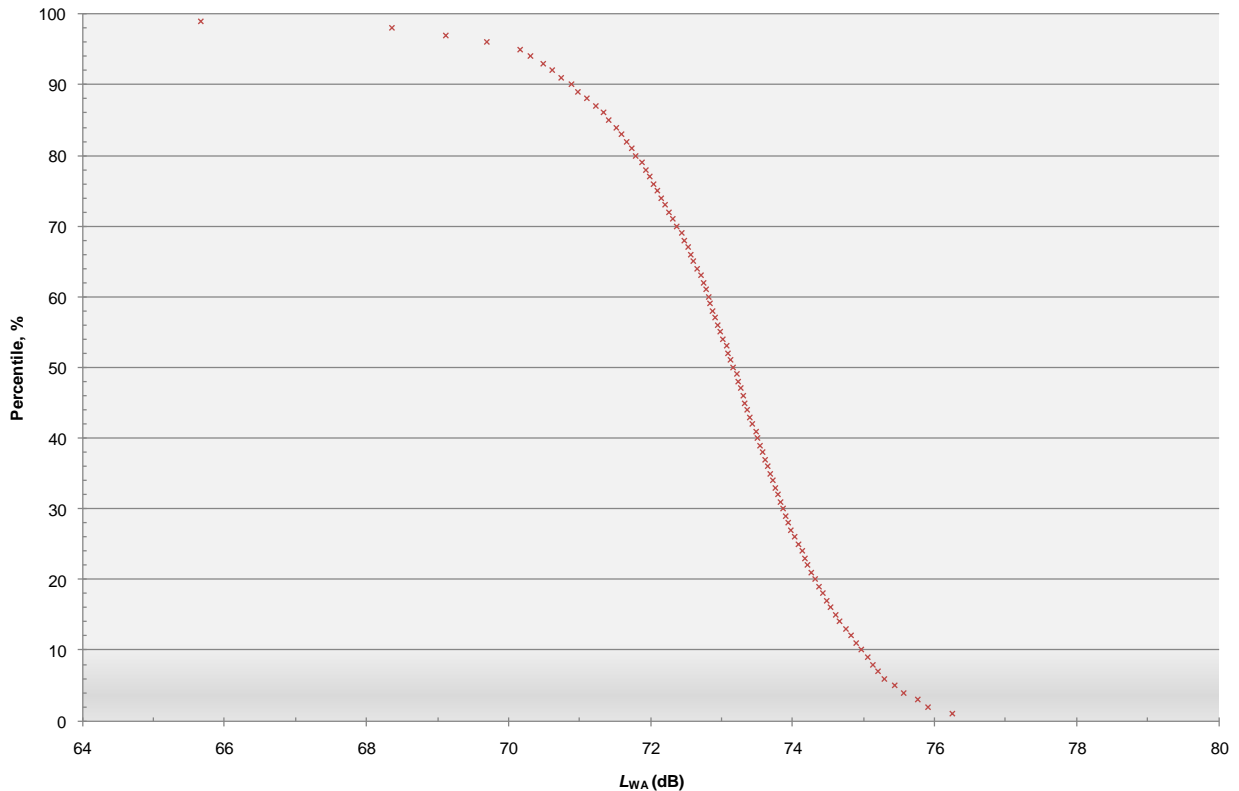

Figure 5-70. 475 West Berkshire (Site 2), Sound Power Level Statistical Analysis

5.8.19. The chart indicates that noise from the ASHP during operation will have a 90% certainty of being within around 3 dB of L_{WA} **73 dB**.

5.8.20. Use of Equation 1 leads to an estimation that noise levels from the unit operating normally would drop to L_{Aeq} 42 dB at a distance separation of approximately **20 m**. If a tonal penalty were to be included, then this distance would rise to around **25 m**. This assumes that the ASHP is located in the common mounting scenario as detailed in Section 3.41, which is not necessarily representative of the actual measured condition.

Vibration

- 5.8.21. An FFT analysis of the vibration levels recorded for normal operation of the ASHP is shown in Figure 5-71. The overall weighted peak vibration level at the wall surface was 0.007 ms^{-2} , below the average perception threshold for whole-body vibration.

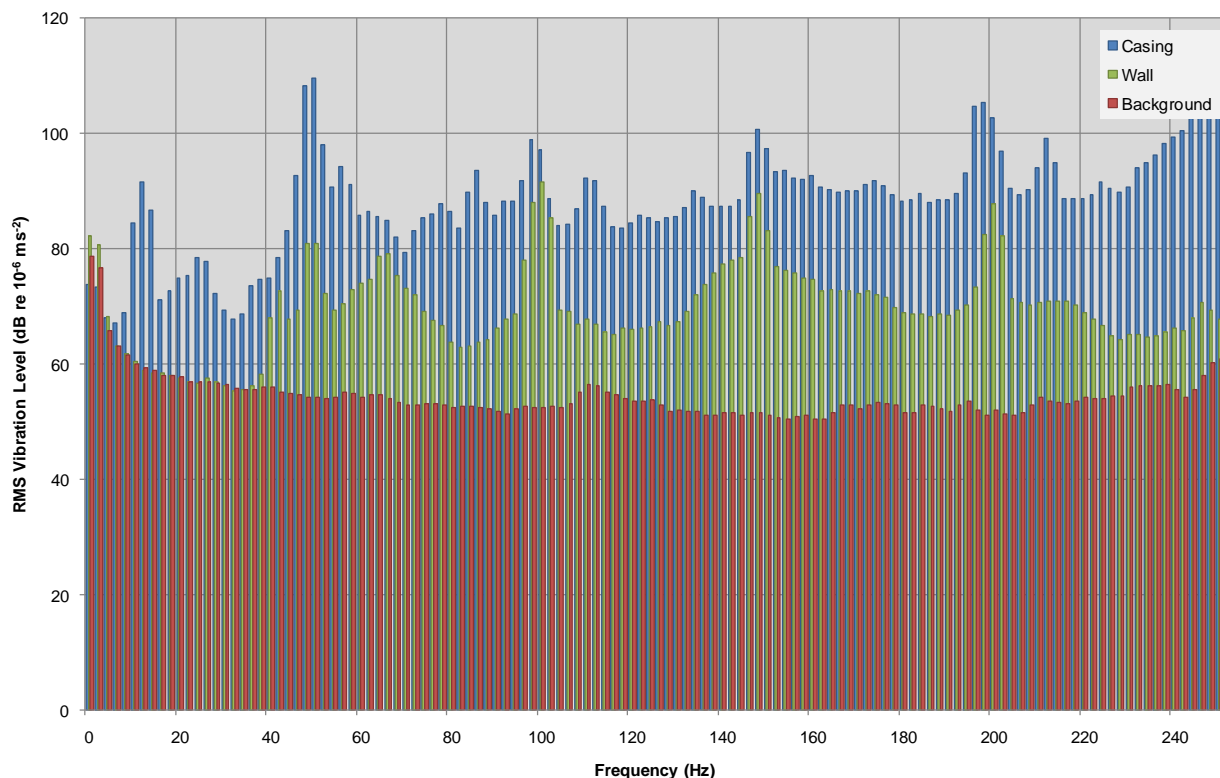

Figure 5-71. 475 West Berkshire (Site 2), Vibration Levels

Discussion

- 5.8.22. The manufacturer has indicated that the speed rating of the fan is nominally 770 rpm, and the compressor speed is 2850 rpm. With four fan blades, the passing frequency would correspond to around 51 Hz, with upper harmonics around 102 and 153 Hz. The compressor speed corresponds with a rotation frequency of around 48 Hz, upper harmonics are clearly visible in the defrost cycle frequency spectrum.

- 5.8.23. From analysis of the spectra, it is apparent that the natural frequencies of the fan during normal operation are not readily distinguishable over those produced by the compressor. It is likely that the natural frequencies of the fan and compressor are occurring so closely that constructive and destructive interference is occurring.
- 5.8.24. During normal operation, the compressor contributes a greater amount of noise than the fan, as well as the majority of tonal content.
- 5.8.25. The vibration data shows that whilst there is in general good attenuation between the ASHP casing and the wall structure, at certain frequencies there is still an amount of transmission that could cause structure-borne noise. It should be noted however, that due to difficulties in effectively mounting the accelerometer to the wall surface directly, it had been mounted to a lightweight timber conduit, which may show exaggerated vibration levels through surface excitation from airborne ASHP noise.
- 5.8.26. A rattle was audible, particularly with the compressor operation, it is therefore possible that some component around the compressor assembly may need tightening or fixing.

5.9 **478 Cotswold (Courtyard)**

Site description

- 5.9.1. The property is located at a farm in a rural location. The ASHP is located within a courtyard, enclosed by stone built single story accommodation. The unit is mounted onto concrete paving slab footings.
- 5.9.2. Subjectively the unit appeared to be operating normally with no audible rattle, resonance or fault.

Equipment set up

- 5.9.3. The 9 Channel PULSE system was used at this site.
- 5.9.4. The unit was mounted above a mixed ground surface of gravel and paving slabs. A stone wall had been built around the ASHP unit as a visual barrier. This interfered with proper placement of microphones, which were placed in a position deemed to be most representative of the ASHP noise emissions.
- 5.9.5. Accelerometers were fixed to the ASHP footings and to the wall surface immediately behind the unit as shown in Picture 5-22. The accelerometers were fixed to the surfaces using cyanoacrylate cement.

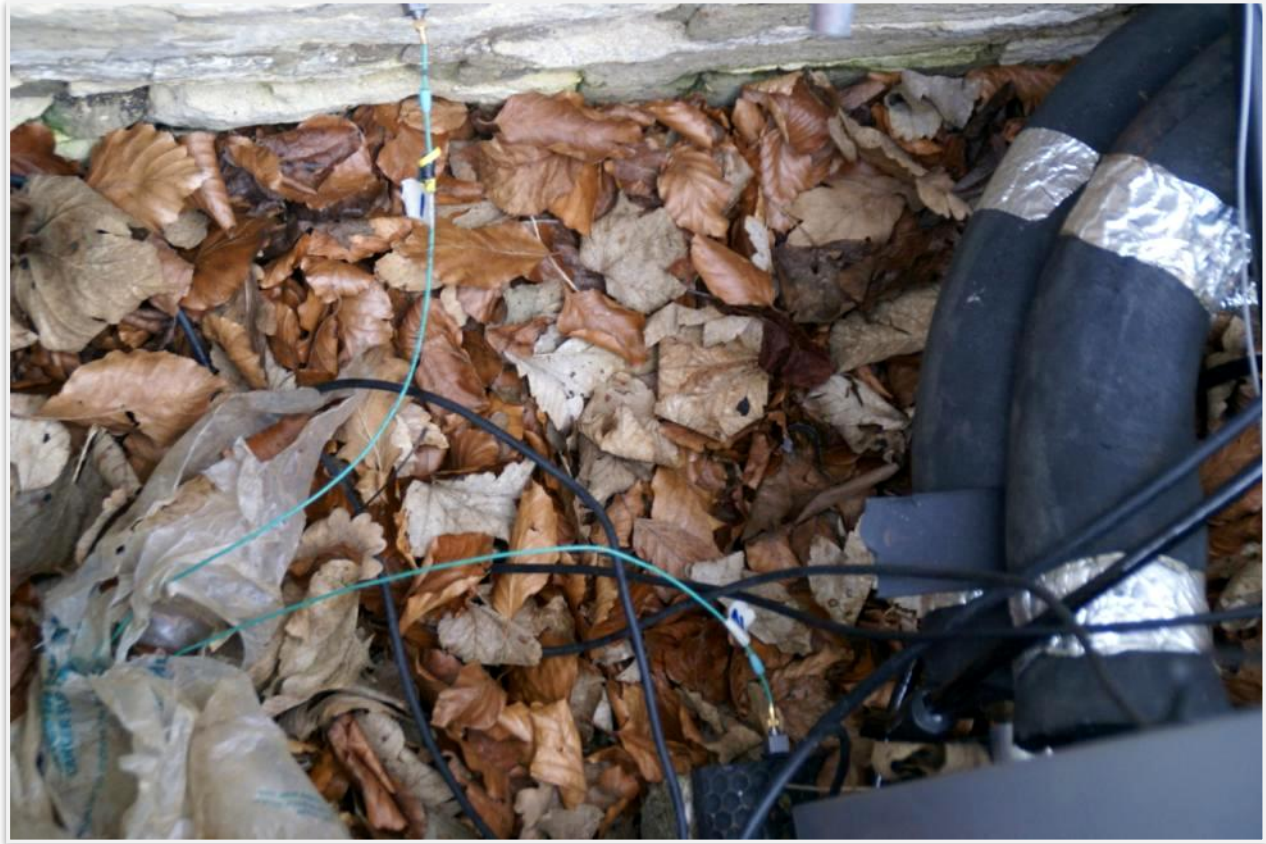

Picture 5-22. 478 Cotswold (Courtyard), Accelerometer Positions

5.9.6. The microphones were mounted on tripods as shown in Picture 5-23. All microphones were positioned 1 m from the ASHP casing, with the exception of the microphone to the left, which had a separation of 60 cm.



Picture 5-23. 478 Cotswold (Courtyard), ASHP and Microphone Arrangement

Measurement Results

- 5.9.7. Figure 5-72 presents the $L_{Aeq(1min)}$ measured noise levels at the microphone 1m in front of the unit set against time, along with the per-minute logged ASHP power consumption. Equipment failure prevented recording between 1/2/11 and 4/2/11.

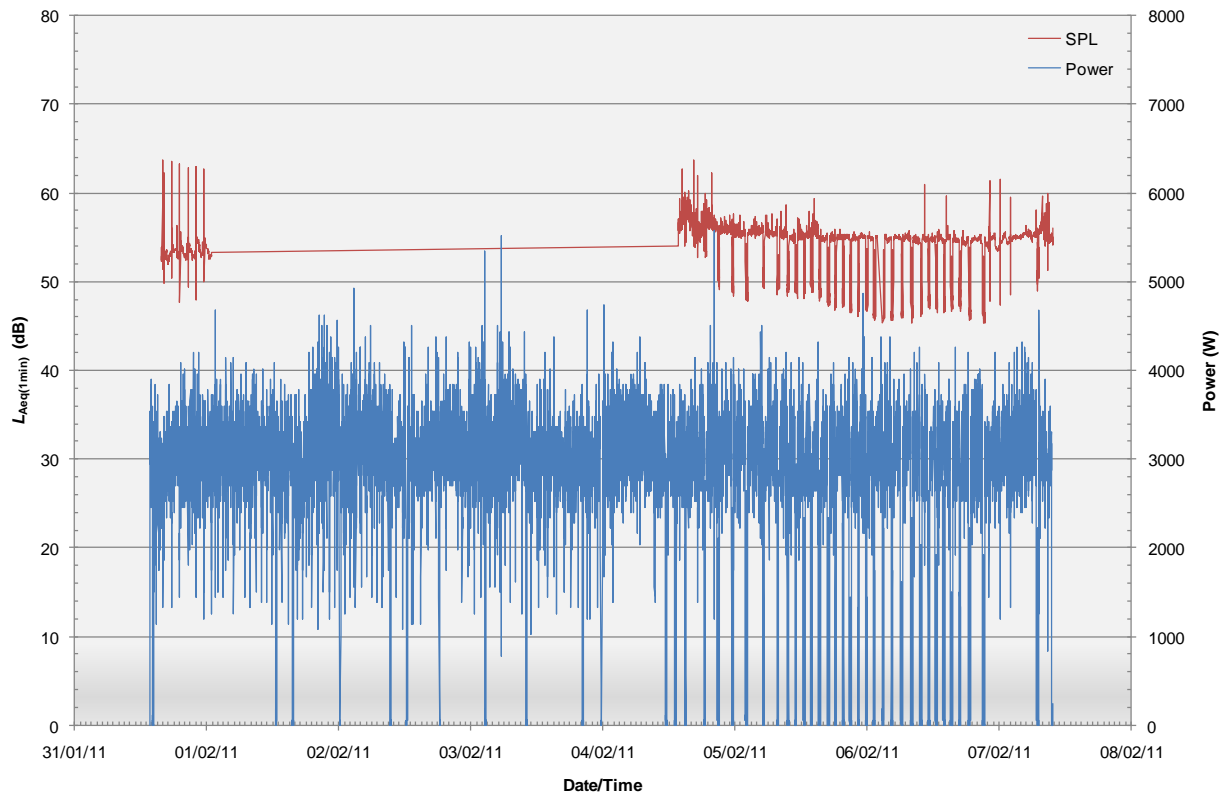

Figure 5-72. 478 Cotswold (Courtyard), SPL and Power Consumption vs Time

- 5.9.8. The chart highlights that the ASHP is cycling on and off, at a cycle interval determined by the power demands of the system. Throughout the measurement period, the ASHP was operational for approximately 85% of the time.
- 5.9.9. The data shows an increase in measured noise level during periods when the ASHP is operating.

Measurement Analysis

- 5.9.10. Figure 5-73 presents a scatter diagram showing the noise levels against the power consumption, for the periods when the ASHP was operating. The chart shows no apparent link between power and noise level.

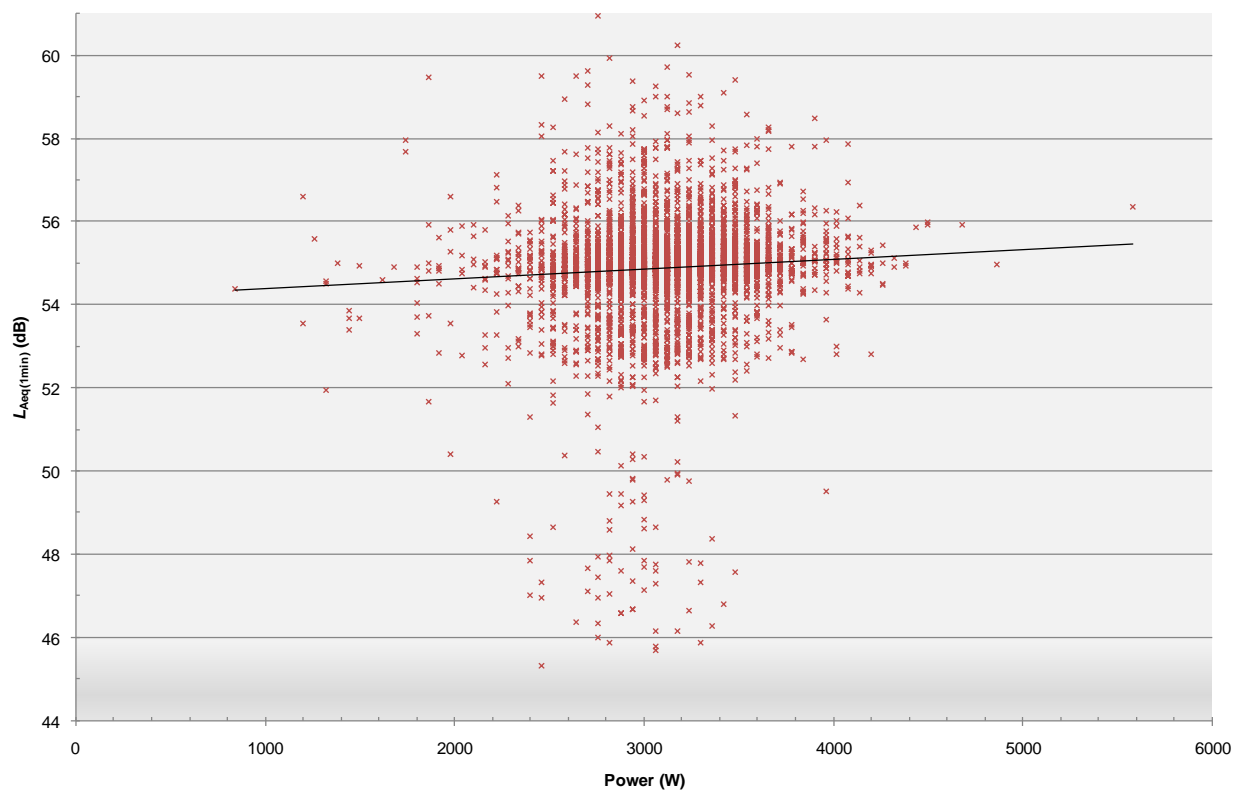

Figure 5-73. 478 Cotswold (Courtyard), SPL vs Power Consumption

5.9.11. Figure 5-74 presents a statistical analysis plot of the percentage of time that a specific noise level would be recorded, when the ASHP is under operation. From this confidence intervals can be presented for the typical noise levels.

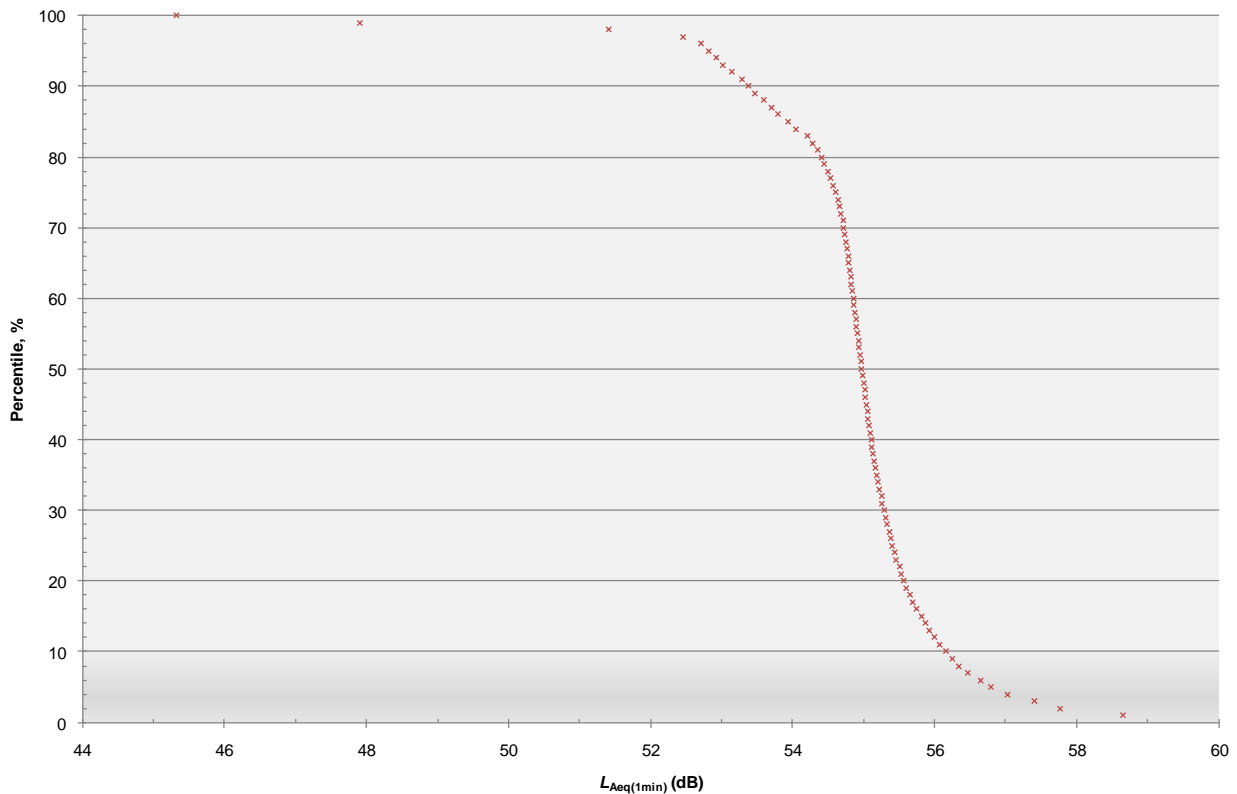

Figure 5-74. 478 Cotswold (Courtyard), SPL Statistical Analysis

- 5.9.12. The chart indicates that noise from the ASHP during operation will have a 90% certainty of being within around 3 dB of $L_{Aeq(1min)}$ **55 dB**. The corresponding total ASHP noise dose over the whole assessment period is calculated as $L_{Aeq(1week)}$ 54 dB.

Defrost Cycle

- 5.9.13. Analysis of the measurements failed to identify defrost cycles with any certainty. Whilst certain short periods of operation were revealed within the measurement data, the analysis has shown the noise to be very similar to that of a 'normal' operating condition. It is therefore likely that either no defrost cycles occurred during the measurements or that the sound characteristic during the defrost cycle is similar to that during normal operation.

Directivity

5.9.14. Table 5-9 shows the directivity in noise emissions from the unit by comparing the noise levels at the different microphones, for a typical period of ASHP operation.

Table 5-9: Directivity Analysis of the ASHP Noise Emissions $L_{Aeq(1min)}$ dB 478 Cotswold (Courtyard), normal operation				
Microphone Location	Front	Left	Right	Above
Typical Microphone Level	52	52	52	55
Change from front microphone	-3	-3	-3	-

5.9.15. It is seen that the ASHP exhibits some directivity, such that noise is greatest in line with the fan.

Frequency analysis

5.9.16. For the frequency analysis, a Fast Fourier Transform (FFT) of the signal was performed, averaged over a representative one minute period at a frequency resolution of 2 Hz. The resulting frequency spectrum for the ASHP operating under normal conditions is given in Figure 5-75.

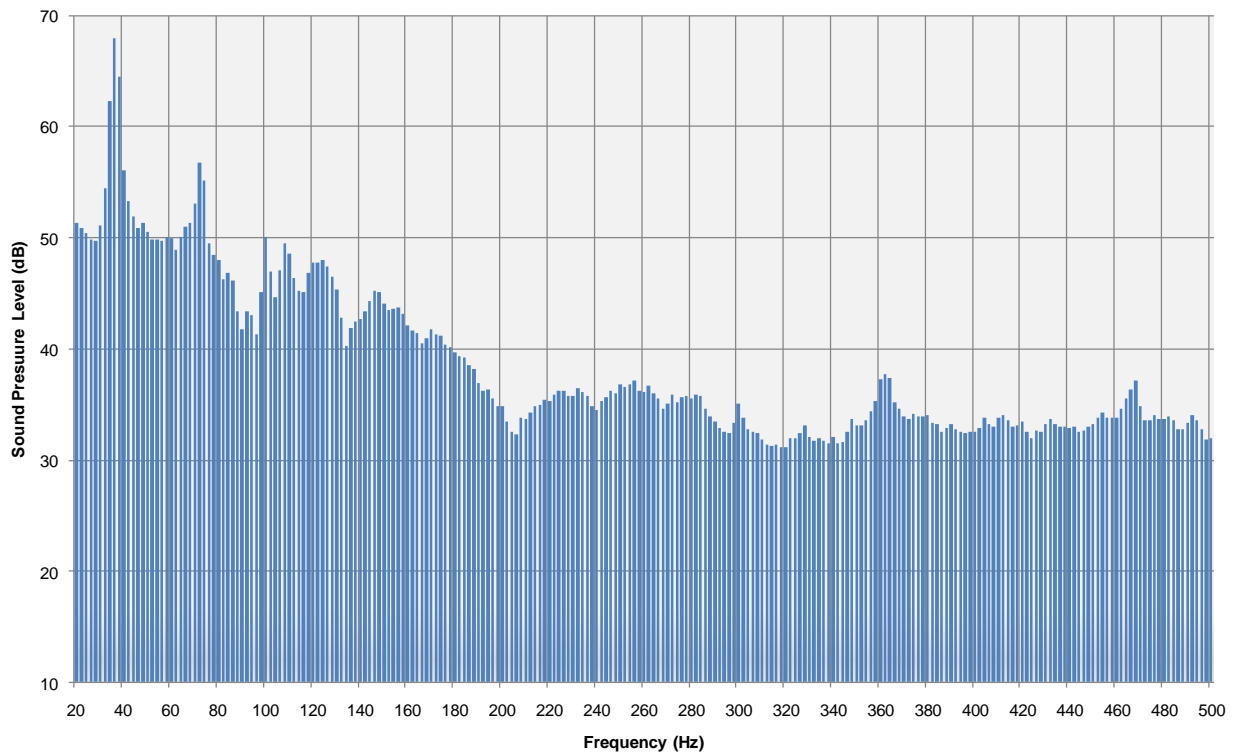
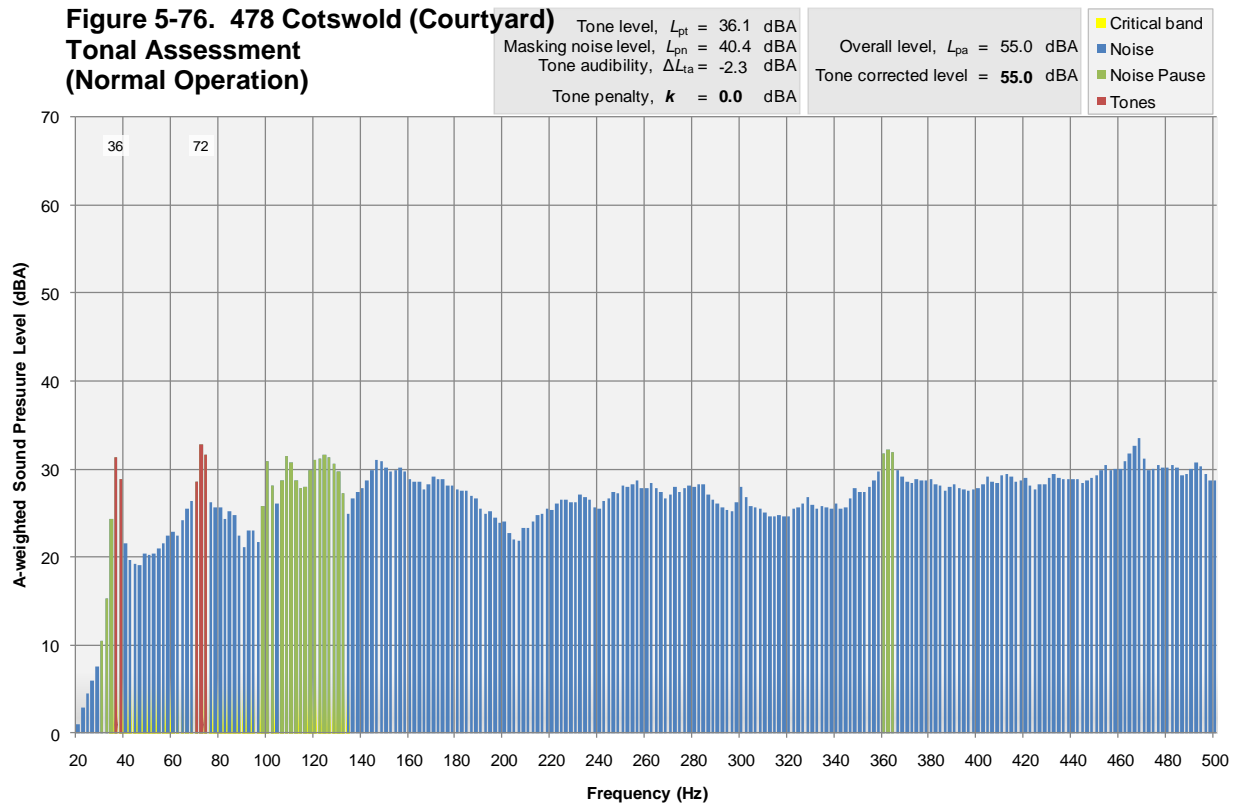

Figure 5-75. 478 Cotswold (Courtyard), Sound Pressure Level Frequency Spectrum (Normal Operation)

5.9.17. Tonal analysis of the frequency spectrum shown in Figure 5-75 has been undertaken in accordance with the Joint Nordic Method (v2). The resulting tonal assessment is presented in Figure 5-76, showing that the tones identified within the spectrum would lead to a **0 dB tonal penalty** for normal operation.

**Figure 5-76. 478 Cotswold (Courtyard)
Tonal Assessment
(Normal Operation)**



Sound Power Level calculations

5.9.18. Figure 5-77 presents a statistical analysis plot of the percentage of time that a specific sound power level would be recorded, when the ASHP is under operation.

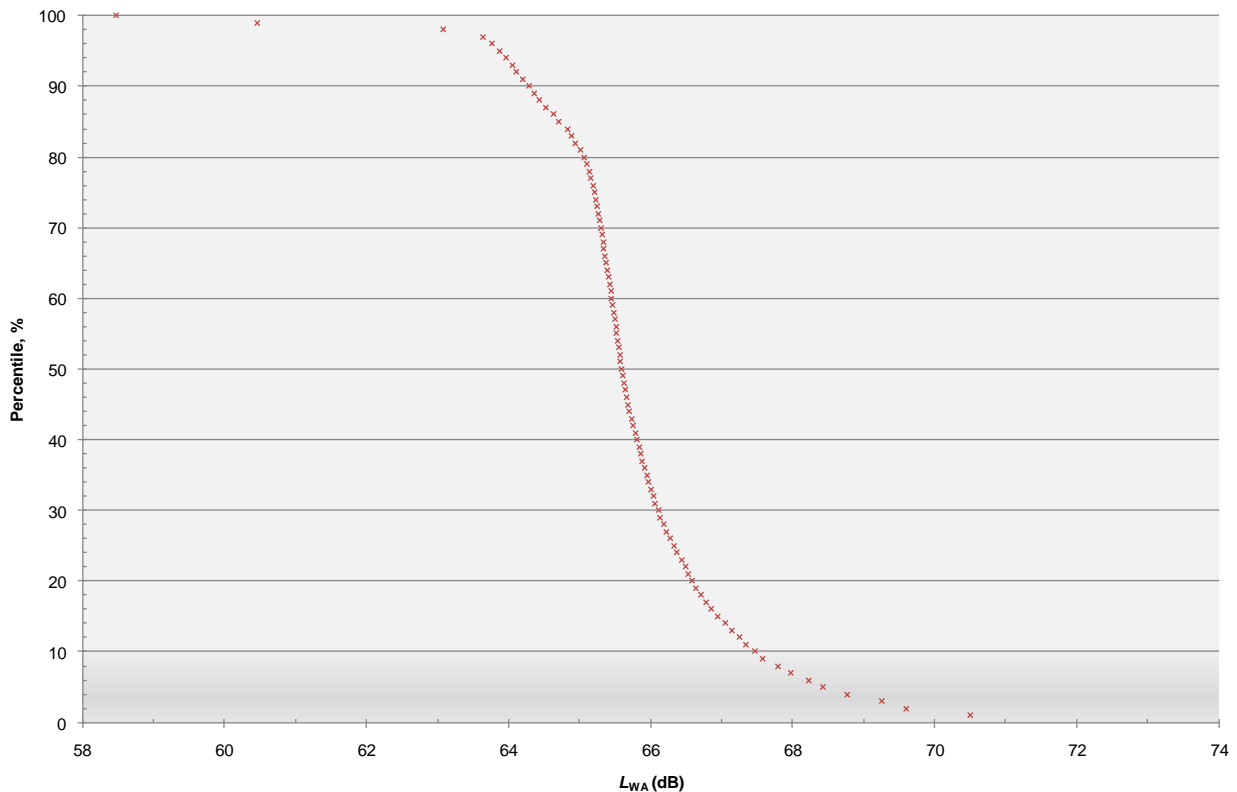

Figure 5-77. 478 Cotswold (Courtyard), Sound Power Level Statistical Analysis

- 5.9.19. The chart indicates that noise from the ASHP during operation will have a 90% certainty of being within around 3 dB of L_{WA} **66 dB**.
- 5.9.20. Use of Equation 1 leads to an estimation that noise levels from the unit operating normally would drop to L_{Aeq} 42 dB at a distance separation of approximately **9 m**. This assumes that the ASHP is located in the common mounting scenario as detailed in Section 3.41, which is not necessarily representative of the actual measured condition.

Vibration

- 5.9.21. An FFT analysis of the vibration levels recorded on the ASHP casing for normal operation is shown in Figure 5-78. No vibration was measureable at the wall surface which was likely to be due to the high mass of the wall and the ASHP isolation.

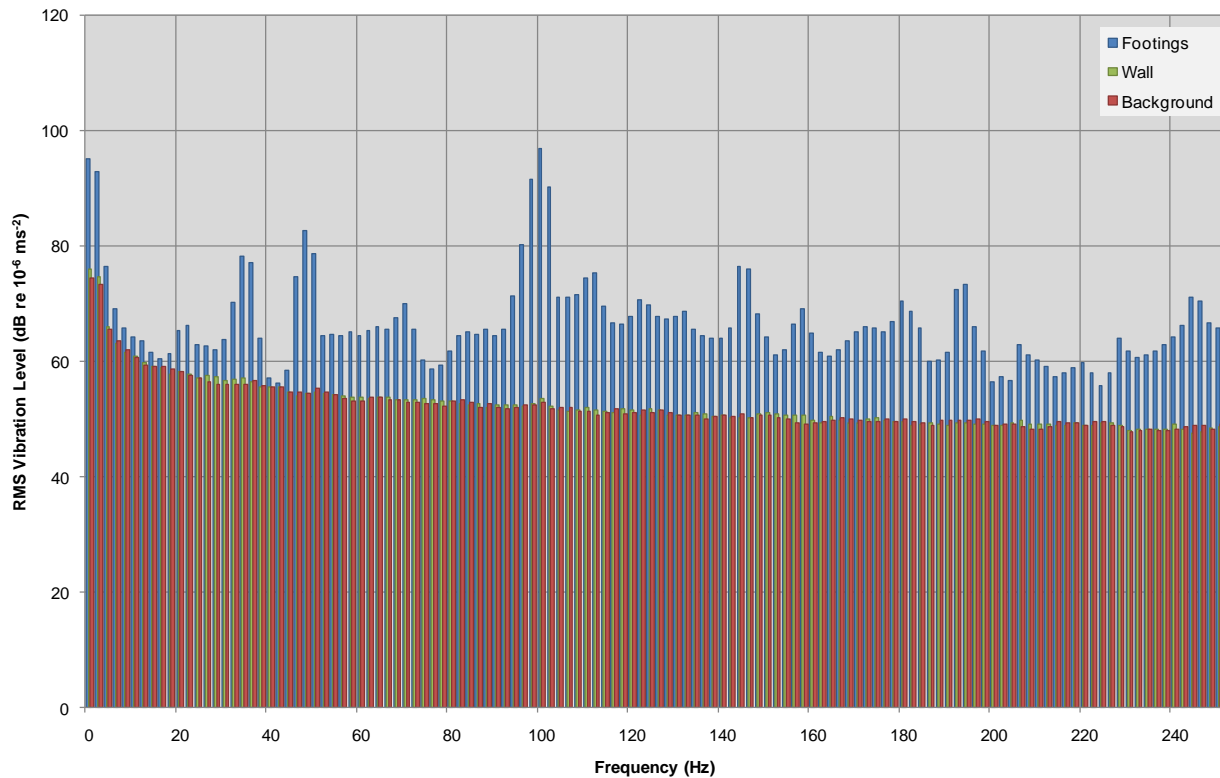

Figure 5-78. 478 Cotswold (Courtyard), Vibration Levels

Discussion

- 5.9.22. The manufacturer has not provided details of the fan speed rating. The compressor speed is 2900 rpm, which corresponds with a rotation frequency of around 48 Hz. It should be noted that tones related to this frequency are only seen in the vibration spectrum, not in the sound spectra. This indicates that tones from the compressor have either been well attenuated in the design of the ASHP, or that the frequencies seen in the vibration spectrum are due to an unrelated mechanism, for example, electrical noise.
- 5.9.23. It is likely that the tones observed at 36 and 72 Hz are due to the fan. Assuming that there are four fan blades, as is common for ASHP units, this corresponds to a rotation frequency of 540 rpm.

5.10 **478 Cotswold (Stables)**

Site description

- 5.10.1. The property is located at a farm in a rural location. The ASHP is located within an open stable area, which was constructed with a high corrugated metal roof. The unit is mounted onto concrete slab footings.
- 5.10.2. Subjectively the unit appeared to be operating normally with no audible rattle, resonance or fault.

Equipment set up

- 5.10.3. The 5 Channel PULSE system was used at this site.
- 5.10.4. The unit was mounted above a mixed ground surface of concrete and straw, in front of a stone wall.
- 5.10.5. Unlike most ASHP units, the fan at this site discharged to the top of the unit.
- 5.10.6. Accelerometers were fixed to the ASHP footings as shown in Picture 5-24. The accelerometer was fixed to the surface using cyanoacrylate cement.

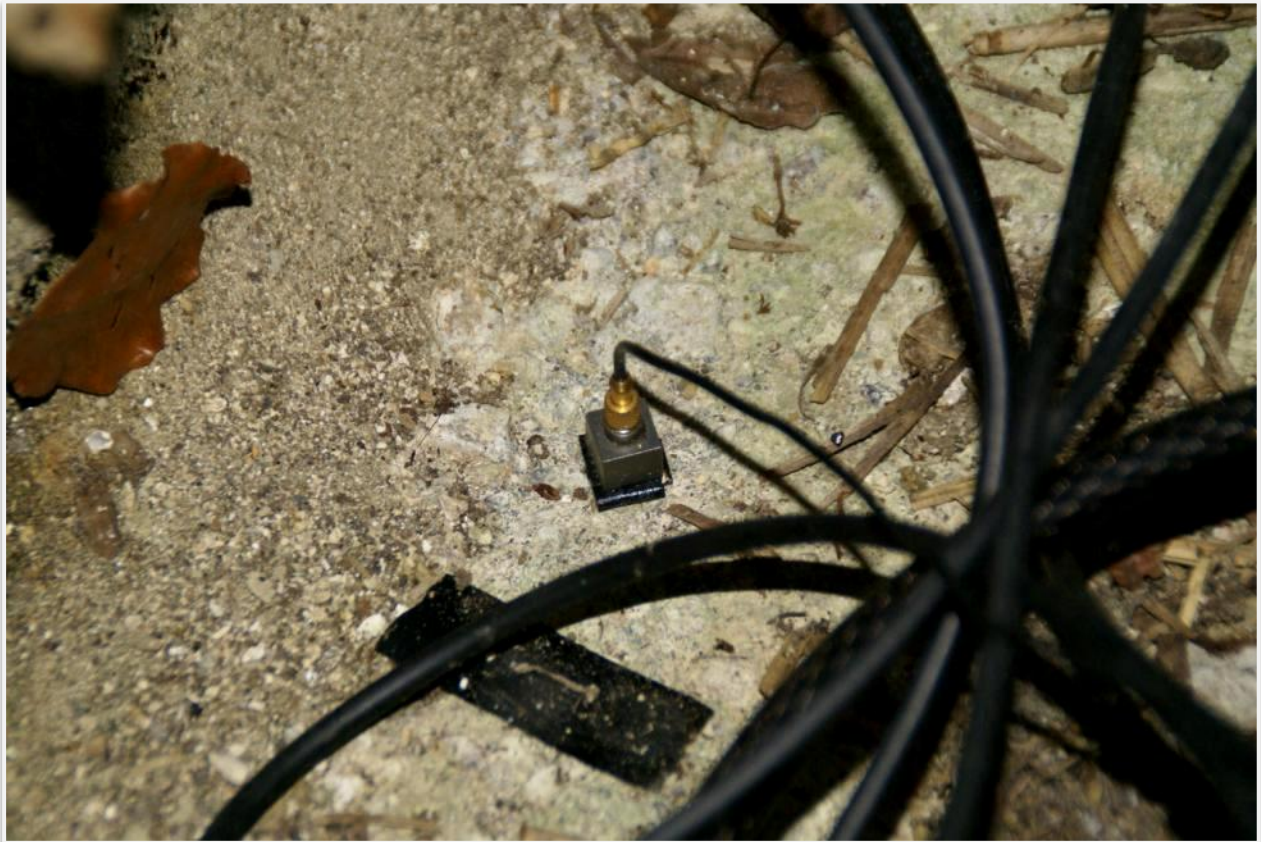

Picture 5-24. 479 Cotswold (Stables), Footings-mounted Accelerometer

5.10.7. The microphones were mounted on temporary framework as shown in Picture 5-25. All microphones were positioned 1 m from the ASHP casing, with the exception of the microphone to the left, which had a separation of 60 cm.



Picture 5-25. 479 Cotswold (Stables), ASHP and Microphone Arrangement

Measurement Results

- 5.10.8. Figure 5-79 presents the $L_{Aeq(1min)}$ measured noise levels at the microphone 1m in front of the unit set against time, along with the per-minute logged ASHP power consumption. Equipment failure prevented recording of acoustical data between 1/2/11 and 4/2/11.

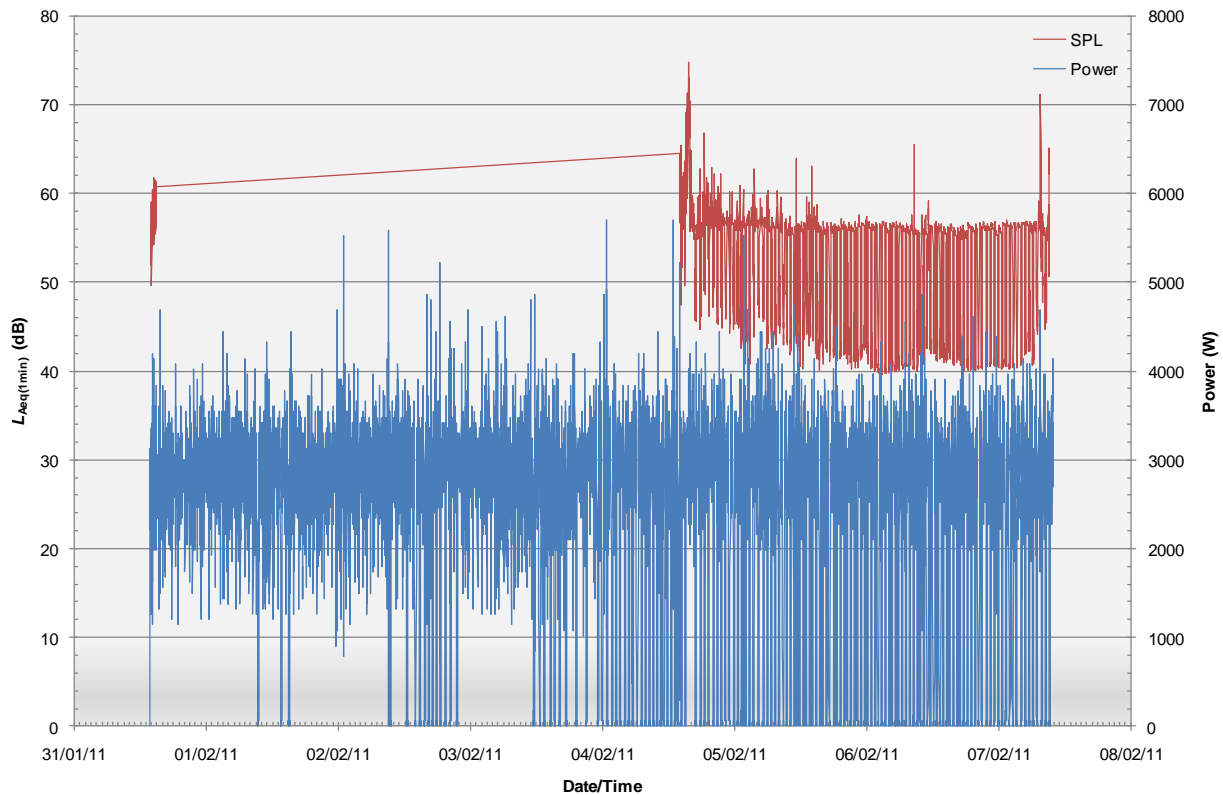

Figure 5-79. 479 Cotswold (Stables), SPL and Power Consumption vs Time

5.10.9. The chart highlights that the ASHP is cycling on and off, at a cycle interval determined by the power demands of the system. Throughout the measurement period, the ASHP was operational for approximately 62% of the time.

5.10.10. The data shows an increase in measured noise level during periods when the ASHP is operating.

Measurement Analysis

5.10.11. Figure 5-80 presents a scatter diagram showing the noise levels against the power consumption, for the periods when the ASHP was operating. The chart shows no apparent link between power and noise level.

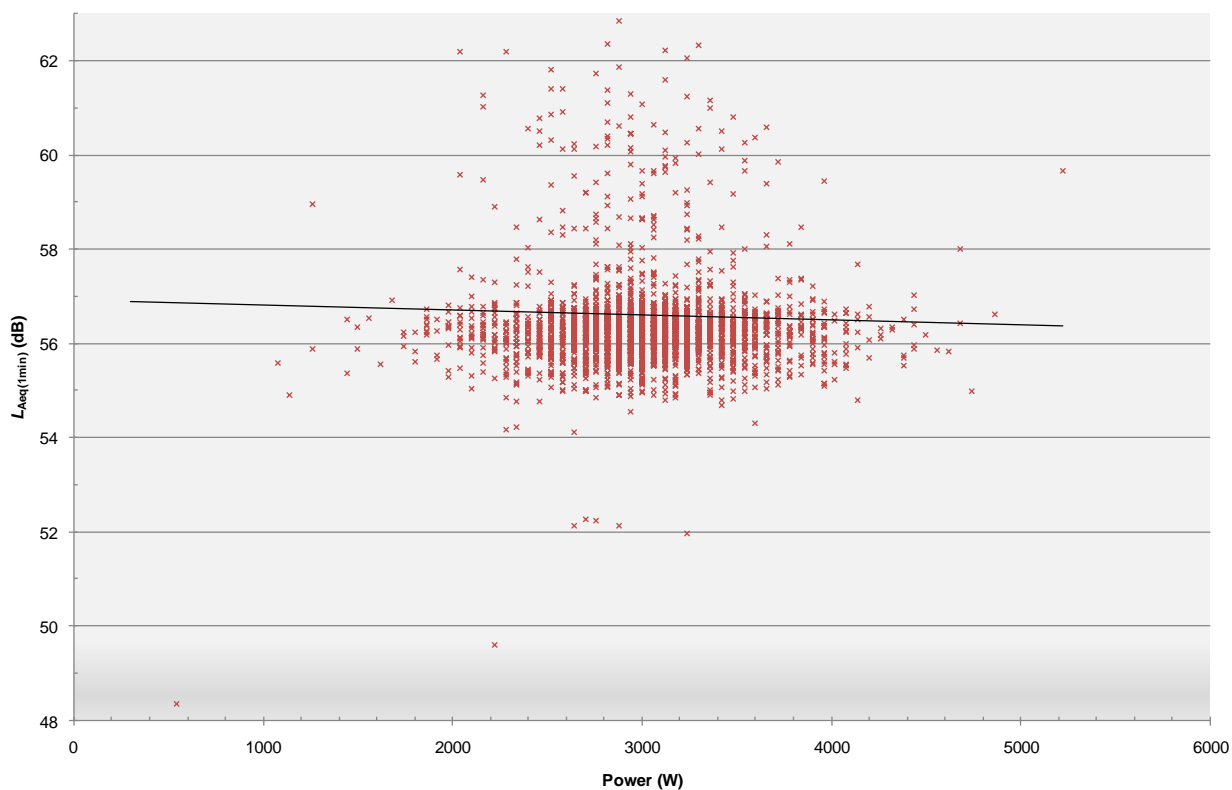

Figure 5-80. 479 Cotswold (Stables), SPL vs Power Consumption

5.10.12. Figure 5-74 presents a statistical analysis plot of the percentage of time that a specific noise level would be recorded, when the ASHP is under operation. From this confidence intervals can be presented for the typical noise levels.

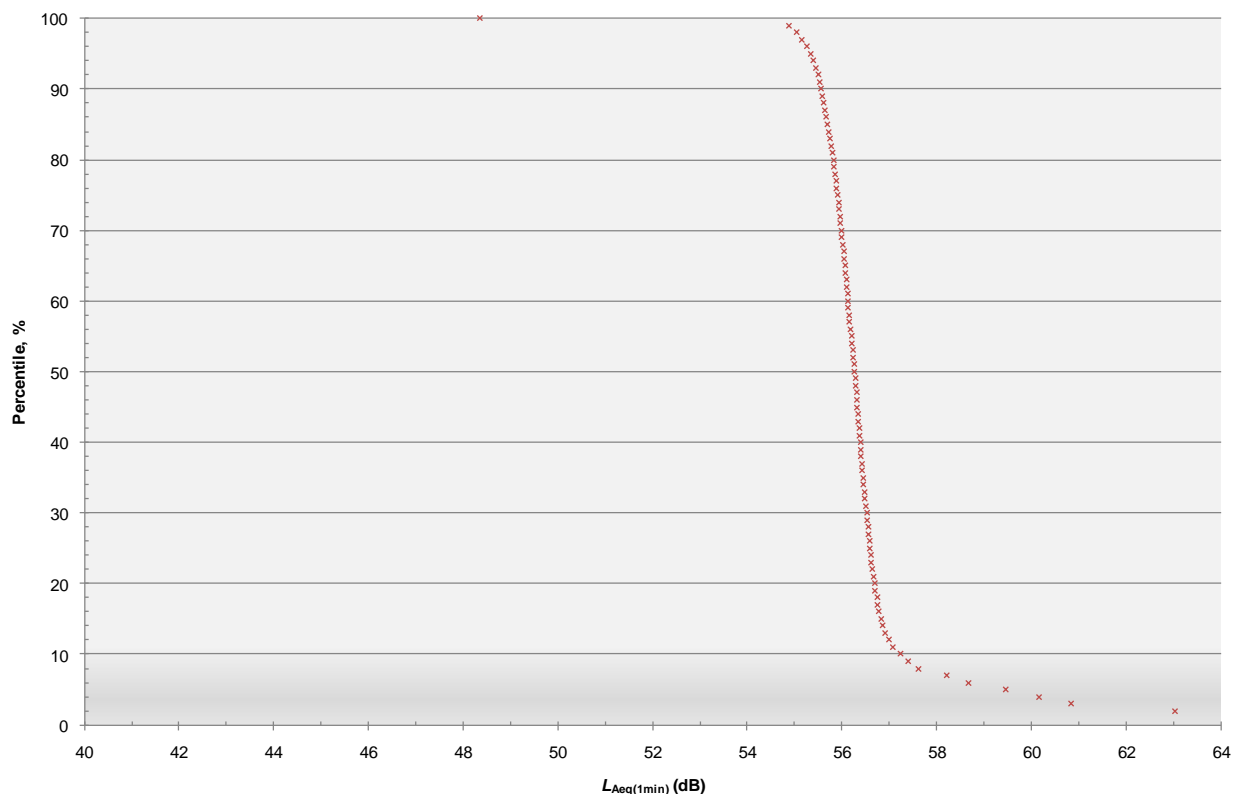

Figure 5-81. 479 Cotswold (Stables), SPL Statistical Analysis

5.10.13. The chart indicates that noise from the ASHP during operation will have a 90% certainty of being within around 3 dB of $L_{Aeq(1min)}$ **56 dB**. The corresponding total ASHP noise dose over the whole assessment period is calculated as $L_{Aeq(1week)}$ 54 dB.

Defrost Cycle

5.10.14. Analysis of the measurements failed to identify defrost cycles with any certainty. Whilst certain short periods of operation were revealed within the measurement data, the analysis has shown the noise to be very similar to that of a 'normal' operating condition. It is therefore likely that either no defrost cycles occurred during the measurements or that the sound characteristic during the defrost cycle is similar to that during normal operation.

Directivity

5.10.15. Table 5-10 shows the directivity in noise emissions from the unit by comparing the noise levels at the different microphones, for a typical period of ASHP operation.

Table 5-10: Directivity Analysis of the ASHP Noise Emissions $L_{Aeq(1min)}$ dB 479 Cotswold (Stables), normal operation				
Microphone Location	Front	Left	Right	Above
Typical Microphone Level	51	54	52	56
Change from front microphone	-5	-2	-4	-

5.10.16. It is seen that the ASHP exhibits some directivity, such that noise is greatest in line with the fan.

Frequency analysis

5.10.17. For the frequency analysis, a Fast Fourier Transform (FFT) of the signal was performed, averaged over a representative one minute period at a frequency resolution of 2 Hz. The resulting frequency spectrum for the ASHP operating under normal conditions is given in Figure 5-82.

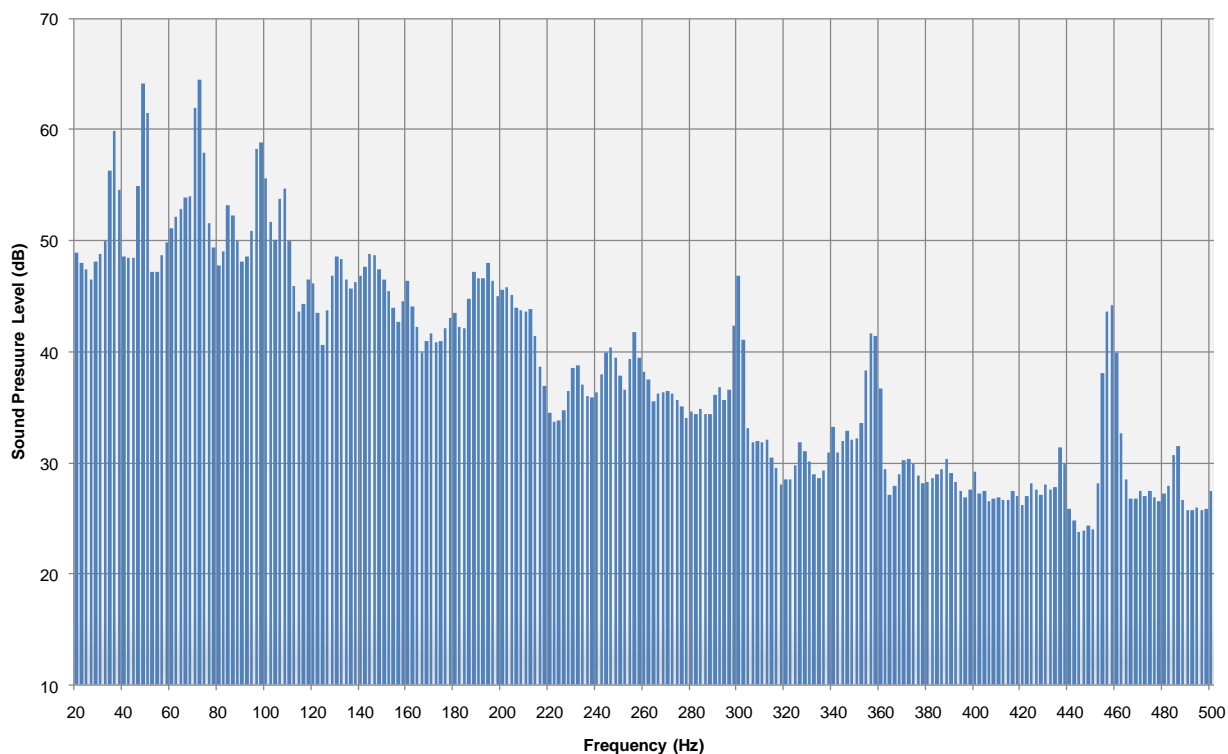
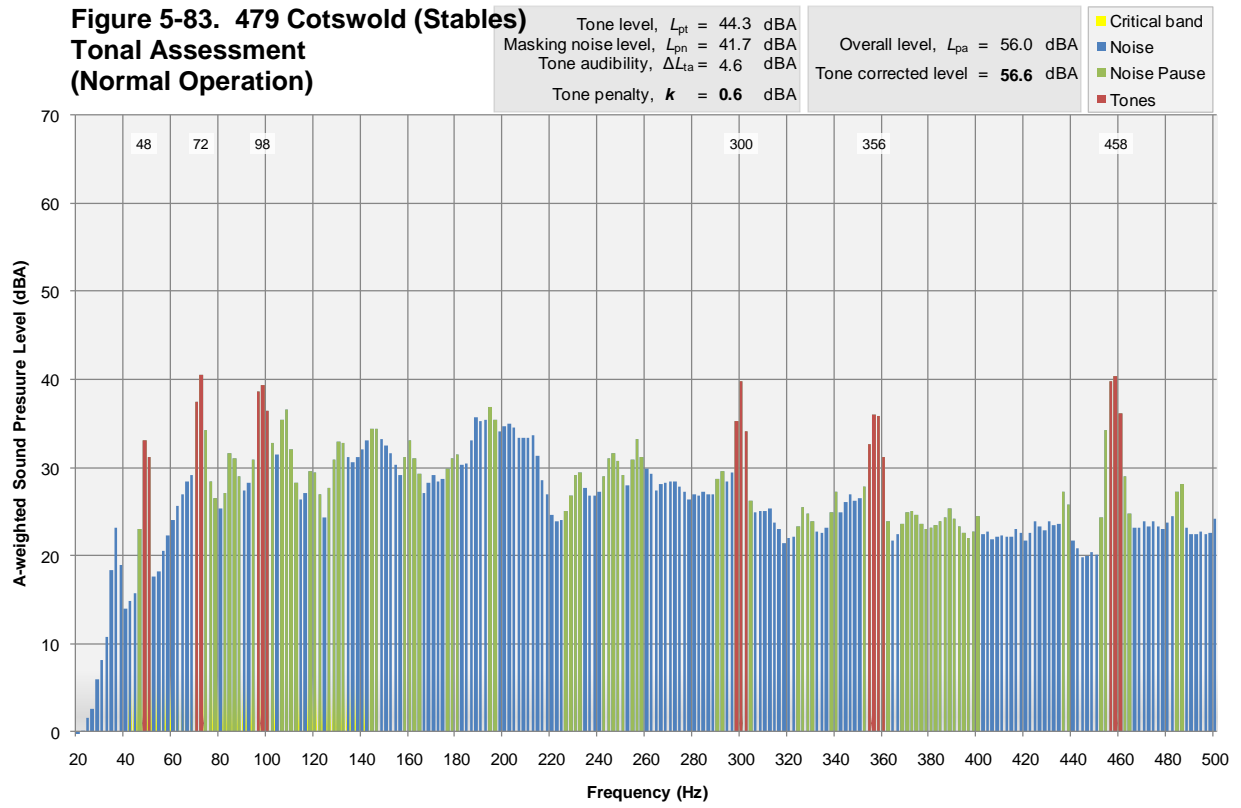

Figure 5-82. 479 Cotswold (Stables), Sound Pressure Level Frequency Spectrum (Normal Operation)

5.10.18. Tonal analysis of the frequency spectrum shown in Figure 5-82 has been undertaken in accordance with the Joint Nordic Method (v2). The resulting tonal assessment is presented in Figure 5-83, showing that the tones identified within the spectrum would lead to a **1 dB tonal penalty** for normal operation.

**Figure 5-83. 479 Cotswold (Stables)
Tonal Assessment
(Normal Operation)**



Sound Power Level calculations

5.10.19. Figure 5-84 presents a statistical analysis plot of the percentage of time that a specific sound power level would be recorded, when the ASHP is under operation.

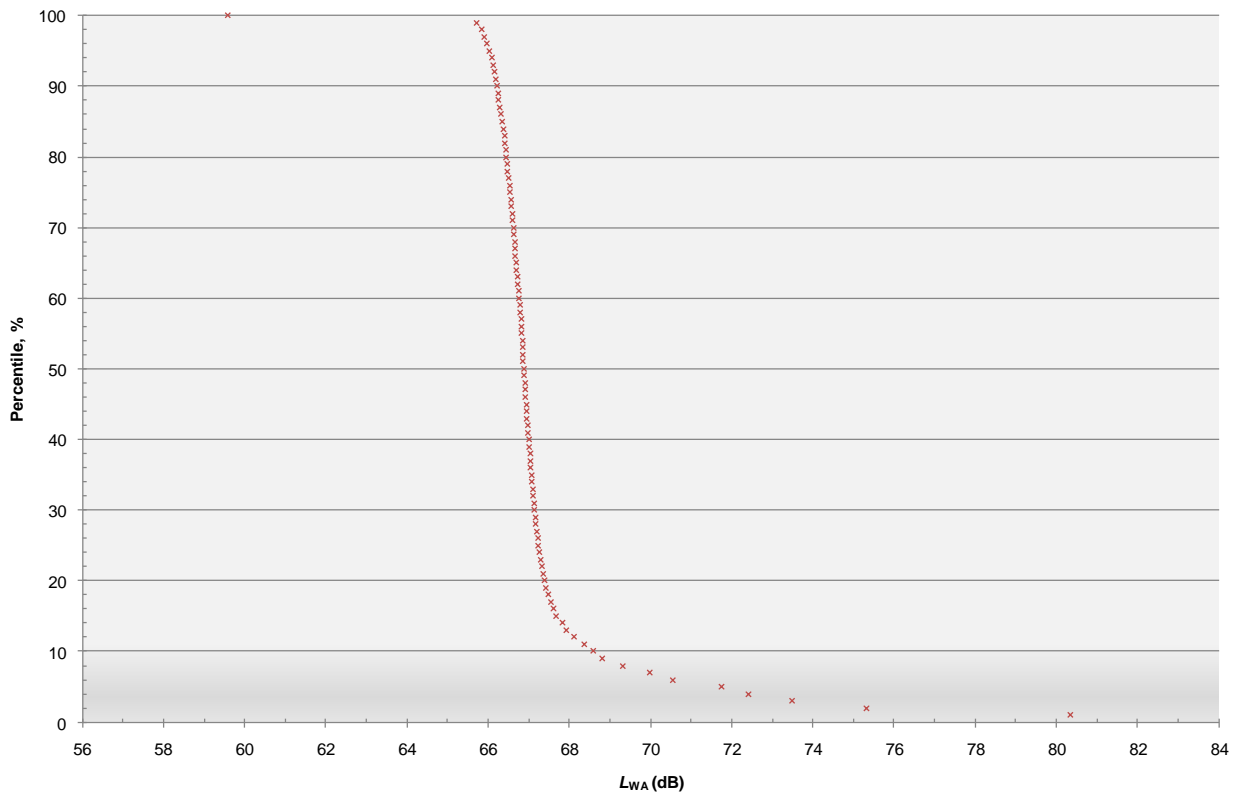

Figure 5-84. 479 Cotswold (Stables), Sound Power Level Statistical Analysis

5.10.20. The chart indicates that noise from the ASHP during operation will have a 90% certainty of being within around 2 dB of L_{WA} 67 dB.

5.10.21. Use of Equation 1 leads to an estimation that noise levels from the unit operating normally would drop to L_{Aeq} 42 dB at a distance separation of approximately **10 m**. If the tonal correction were to be applied, this distance would rise to **11 m**. This assumes that the ASHP is located in the common mounting scenario as detailed in Section 3.41, which is not necessarily representative of the actual measured condition.

Vibration

5.10.22. An FFT analysis of the vibration levels recorded for normal operation of the ASHP is shown in Figure 5-85. Only a small amount of vibration from the ASHP was measureable on the footings.

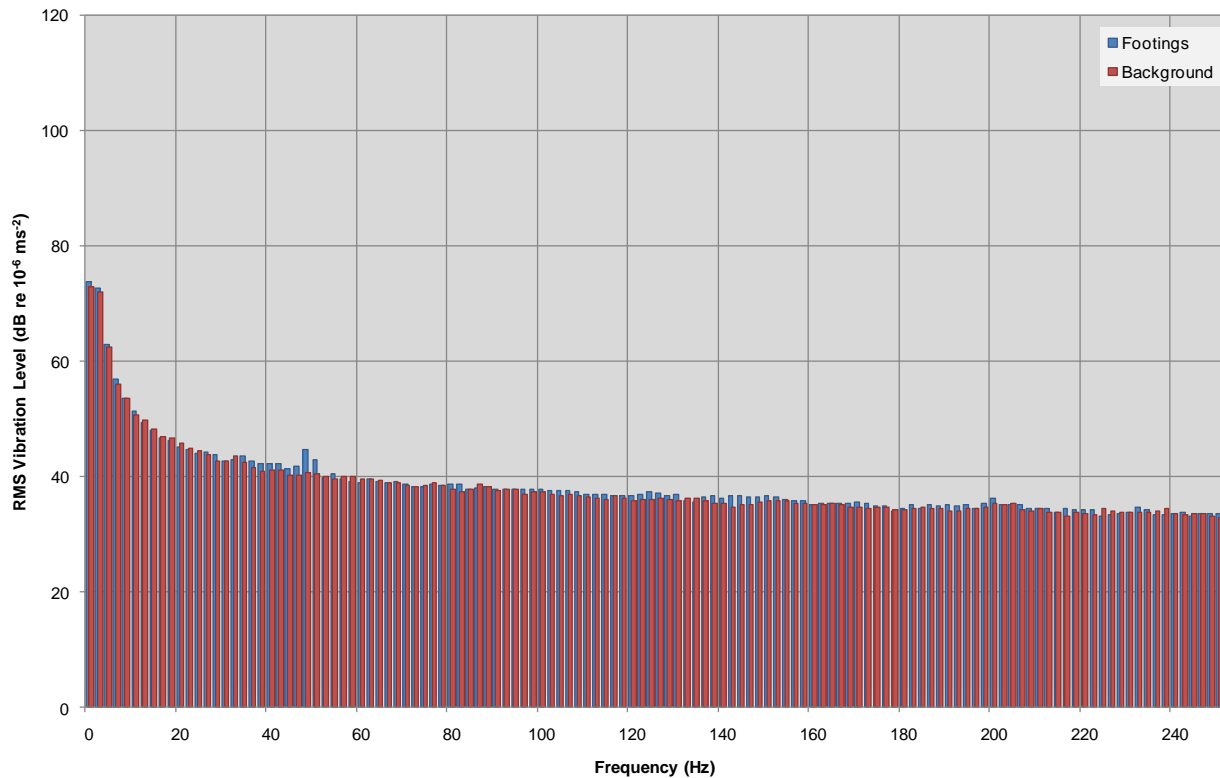

Figure 5-85. 479 Cotswold (Stables), Vibration Levels

Discussion

5.10.23. The manufacturer has not provided details of the fan speed rating. The compressor speed is 2900 rpm, which corresponds with a rotation frequency of around 48 Hz. Tones related to this frequency are seen in both the vibration spectrum, and the sound spectra.

5.10.24. It is likely that the tones observed at 36 and 72 Hz are due to the fan. Assuming that there are four fan blades, as is common for ASHP units, this corresponds to a rotation frequency of 540 rpm.

5.10.25. From analysis of the spectra, it is likely that the fan and compressor provide similar levels of noise and tonal content for this ASHP.

6.0 Suggestions and Conclusions

- 6.1 The report has found that site installations of the ASHPs are generally in line with predictions derived from manufacturers sound power data. However the manufacturer data does not identify if the ASHP produces significant acoustic tones.
- 6.2 A number of the ASHPs surveyed were identified as having significant acoustic tones, particularly during the defrost cycle. The tonal content was found to be typically in the low frequency region. This tonal content can adversely affect the subjective acceptability of the ASHP noise signature.
- 6.3 No correlation between an ASHP's noise output and ambient temperature or power consumption was identified.
- 6.4 The ASHP installations surveyed did not appear to give rise to significant levels of vibration in surrounding structures.
- 6.5 Manufacturers should be encouraged to present a uniformed set of noise data for their ASHPs in a similar manner to the Micro Wind Turbine Noise Labels. This should ideally include sound power levels, sound pressure levels at a range of distances in addition to a tonal penalty figure calculated in accordance with JMN2 or ISO 1996-2.
- 6.6 It is clear from the investigations of a GSHP that there is potential to improve the acoustic insulation of ASHPs. The designers of ASHPs should be encouraged to compartmentalise the compressor and internal workings of the system as much as possible such that an acoustic box is formed which prevents the compressor noise radiating out of the open fan enclosure.

- 6.7 A well designed acoustic enclosure would typically have a casing mass of at least 10 kg/m^2 . All pipe and electrical penetrations should be well sealed with rubber glands and incorporate flexible joints where possible. The enclosure design should include acoustic absorption material.
- 6.8 Whilst acoustic compressor jackets are available on the market, they would not be expected to provide the same level of attenuation as a well designed and constructed acoustic enclosure.
- 6.9 The ASHP which used a centrifugal fan type appeared to be a noisier arrangement than the ASHPs with axial fan types.
- 6.10 Whilst no amplitude modulation effects were identified within the measured data, ASHP designers should take care that the fan blade passing frequency does not coincide closely with the compressor rotation speed, which could otherwise cause wave interference resulting in a pulsing effect.
- 6.11 The study has shown that vibration effects are not likely to be perceptible with most current ASHP designs. We would recommend that anti-vibration mounts continue to be fitted to the framework for wall-mounted ASHPs, where the wall is common to noise sensitive occupants. Any anti-vibration mounts should have a natural frequency of less than half of the ASHP fan rotational frequency.
- 6.12 As part of further research it is suggested to carry out further dose response investigations in order to ascertain the subjective acceptability of air source heat pumps in a domestic environment. Such a study would ideally utilise auralisation trials. This would serve to further inform on the suitability of any suggested ASHP noise criteria.

Appendix A. Measurement Equipment

For the acoustic measurements the following items of equipment were used.

Equipment	Serial No.
Brüel & Kjær Type 7537-A PULSE Controller Module	2465210
Brüel & Kjær Type 3109 PULSE Input/Output Module	2420577
Brüel & Kjær Type 7540-A PULSE Controller Module	2498403
Brüel & Kjær Type 4189 1/2" Prepolarized Free-field Microphone	2505074
Brüel & Kjær Type 4189 1/2" Prepolarized Free-field Microphone	2505071
Brüel & Kjær Type 4189 1/2" Prepolarized Free-field Microphone	2471991
Brüel & Kjær Type 4189 1/2" Prepolarized Free-field Microphone	2505072
Brüel & Kjær Type 4189 1/2" Prepolarized Free-field Microphone	2496778
Brüel & Kjær Type 4189 1/2" Prepolarized Free-field Microphone	2496775
Brüel & Kjær Type 4189 1/2" Prepolarized Free-field Microphone	2505073
Brüel & Kjær Type 4189 1/2" Prepolarized Free-field Microphone	2471990
Brüel & Kjær UA-1404 Outdoor Microphone Kits	
Brüel & Kjær Type 4508-B Miniature DeltaTron Accelerometer	10230
Brüel & Kjær Type 4508-B Miniature DeltaTron Accelerometer	10022
Brüel & Kjær Type 4508-B Miniature DeltaTron Accelerometer	10233
Brüel & Kjær Type 4231 Sound Calibrator	1780570
Brüel & Kjær Type 4294 Vibration Calibrator	2532254
Davis Vantage Vue Weather Station	D101109B038
Davis Vantage Pro Weather Station	B40527A01A

Appendix B. Calibration Certificates

Appendix C. Measurement Data

Raw PULSE format data is held on external hard disks supplied to DECC.